

FEATURES

- Generates/Detects digital bit patterns for analyzing, evaluating and troubleshooting digital communications systems
- Operates at speeds from DC to 52 MHz
- Programmable polynomial length and feedback taps for generation of any other pseudorandom pattern up to 32 bits in length including: 2^6-1 , 2^9-1 , $2^{11}-1$, $2^{15}-1$, $2^{20}-1$, $2^{23}-1$, and $2^{32}-1$
- Programmable user-defined pattern and length for generation of any repetitive pattern up to 32 bits in length
- Large 32-bit error count and bit count registers
- Software programmable bit error insertion
- Fully independent transmit and receive sections
- 8-bit parallel control port
- Detects test patterns with bit error rates up to 10^{-2}

PIN ASSIGNMENT

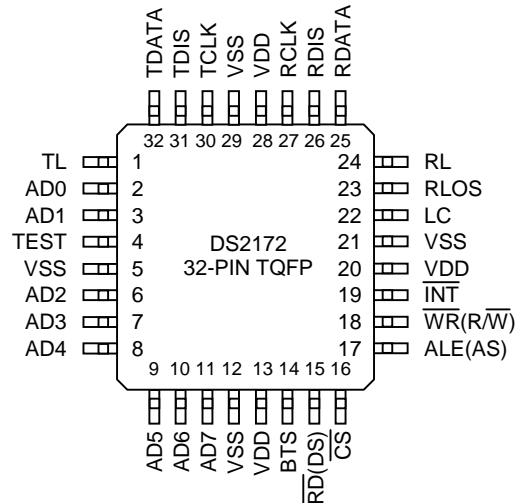

DESCRIPTION

The DS2172 Bit Error Rate Tester (BERT) is a software programmable test pattern generator, receiver, and analyzer capable of meeting the most stringent error performance requirements of digital transmission facilities. Two categories of test pattern generation (Pseudo-random and Repetitive) conform to CCITT/ITU O.151, O.152, O.153, and O.161 standards. The DS2172 operates at clock rates ranging from DC to 52 MHz. This wide range of operating frequency allows the DS2172 to be used in existing and future test equipment, transmission facilities, switching equipment, multiplexers, DACs, Routers, Bridges, CSUs, DSUs, and CPE equipment.

The DS2172 user-programmable pattern registers provide the unique ability to generate loopback patterns required for T1, Fractional-T1, Smart Jack, and other test procedures. Hence the DS2172 can initiate the loopback, run the test, check for errors, and finally deactivate the loopback.

The DS2172 consists of four functional blocks: the pattern generator, pattern detector, error counter, and control interface. The DS2172 can be programmed to generate any pseudorandom pattern with length up to $2^{32}-1$ bits (see Table 5, Note 9) or any user programmable bit pattern from 1 to 32 bits in length. Logic inputs can be used to configure the DS2172 for applications requiring gap clocking such as Fractional-T1, Switched-56, DDS, normal framing requirements, and per-channel test procedures. In addition, the DS2172 can insert single or 10^{-1} to 10^{-7} bit errors to verify equipment operation and connectivity.

1.0 GENERAL OPERATION

1.1 Pattern Generation

The DS2172 is programmed to generate a particular test pattern by programming the following registers:

- Pattern Set Registers (PSR)
- Pattern Length Register (PLR)
- Polynomial Tap Register (PTR)
- Pattern Control Register (PCR)
- Error Insertion Register (EIR)

Please see Tables 4 and 5 for examples of how to program these registers in order to generate some standard test patterns. Once these registers are programmed, the user will then toggle the TL (Transmit Load) bit or pin to load the pattern into the onboard pattern generation circuitry and the pattern will begin appearing at the TDATA pin.

1.2 Pattern Synchronization

The DS2172 expects to receive the same pattern that it transmitted. The synchronizer examines the data at RDATA and looks for characteristics of the transmitted pattern. The user can control the onboard synchronizer with the Sync Enable and Resync bits in the Pattern Control Register.

In pseudorandom mode, the received pattern is tested to see if it fits the polynomial generator as defined in the transmit side. For pseudorandom patterns, only the original pattern and an all ones pattern or an all 0s pattern will satisfy this test. Synchronization in pseudorandom pattern mode should be qualified by using the RA1 and RA0 indicators in the Status Register. Synchronization is declared after $34 + n$ bits are received without error, where n is the exponent in the polynomial from table 4. Once in synchronization (SR0 = 1) any deviation from this pattern will be counted by the Bit Error Count Register.

In repetitive pattern mode a received pattern of the same length as being transmitted will satisfy this test. Synchronization in repetitive pattern mode should be qualified by using the RA1 and RA0 indicators in the Status Register and examining the Pattern Receive Register (PRR0--3). See section 10 for an explanation of the Pattern Receive Register. Once in synchronization (SR.0 = 1) any deviation from this pattern will be counted by the Bit Error Count Register.

1.3 BER Calculation

Users can calculate the actual Bit Error Rate (BER) of the digital communications channel by reading the bit error count out of the Bit Error Count Register (BECR) and reading the bit count out of the Bit Count Register (BCR) and then dividing the BECR value with the BCR value. The user has total control over the integration period of the measurement. The LC (Load Count) bit or pin is used to set the integration period.

1.4 Generating Errors

Via the Error Insertion Register (EIR), the user can intentionally inject a particular error rate into the transmitted data stream. Injecting errors allows users to stress communication links and to check the functionality of error monitoring equipment along the path.

1.5 Power-Up Sequence

On power-up, the registers in the DS2172 will be in a random state. The user must program all the internal registers to a known state before proper operation can be insured.

DS2172 FUNCTIONAL BLOCK DIAGRAM Figure 1

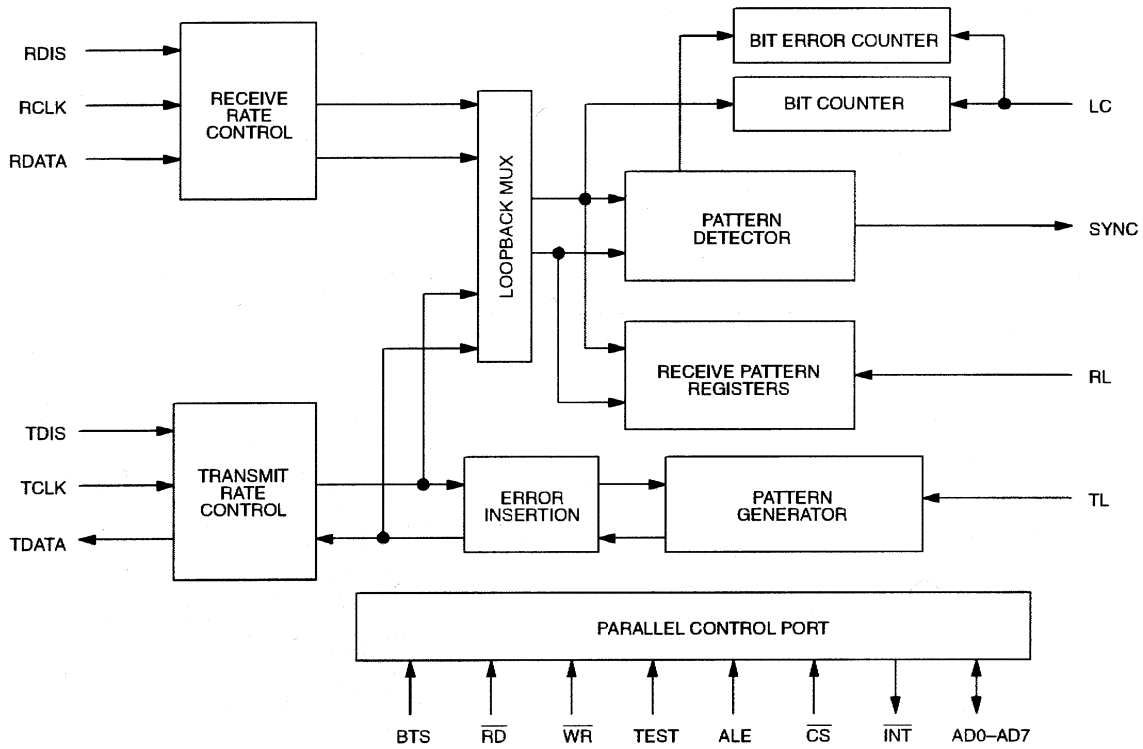

DS2172 PATTERN GENERATION BLOCK DIAGRAM Figure 2

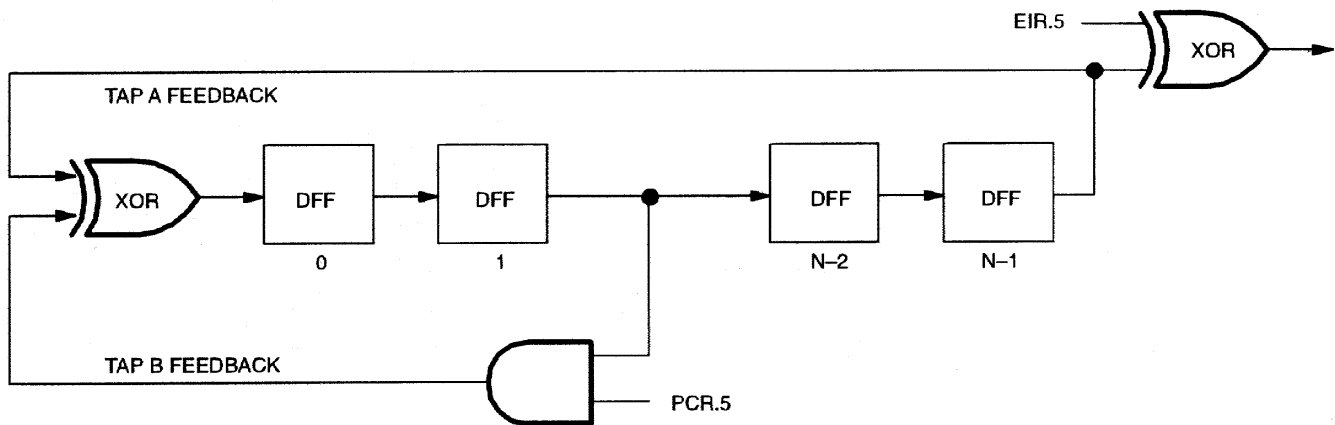

NOTES:

1. Tap A always equals length (N-1) of pseudorandom or repetitive pattern.
2. Tap B can be programmed to any feedback tap for pseudorandom pattern generation.

DETAILED PIN DESCRIPTION Table 1

PIN	SYMBOL	TYPE	DESCRIPTION
1	TL	I	Transmit Load. A positive-going edge loads the pattern generator with the contents of the Pattern Set Registers. The MSB of the repetitive or pseudorandom pattern appears at TDATA after the third positive edge of TCLK from asserting TL. TL is logically OR'ed with PCR.7 and should be tied to V _{SS} if not used. See Figure 8 for timing information.
2	AD0	I/O	Data Bus. An 8-bit multiplexed address/data bus.
3	AD1	I/O	Data Bus. An 8-bit multiplexed address/data bus.
4	TEST	I	Test. Set high to 3-state all output pins ($\overline{\text{INT}}$, AD _x , TDATA, RLOS). Should be tied to V _{SS} to enable all outputs.
5	V _{SS}	-	Signal Ground. 0.0 volts. Should be tied to local ground plane.
6	AD2	I/O	Data Bus. An 8-bit multiplexed address/data bus.
7	AD3	I/O	Data Bus. An 8-bit multiplexed address/data bus.
8	AD4	I/O	Data Bus. An 8-bit multiplexed address/data bus.
9	AD5	I/O	Data Bus. An 8-bit multiplexed address/data bus.
10	AD6	I/O	Data Bus. An 8-bit multiplexed address/data bus.
11	AD7	I/O	Data Bus. An 8-bit multiplexed address/data bus.
12	V _{SS}	-	Signal Ground. 0.0 volts. Should be tied to local ground plane.
13	V _{DD}	-	Positive Supply. 5.0 volts.
14	BTS	I	Bus Type Select. Strap high to select Motorola bus timing; strap low to select Intel bus timing. This pin controls the function of the $\overline{\text{RD}}$ (DS), ALE(AS), and $\overline{\text{WR}}$ (R/ $\overline{\text{W}}$) pins. If BTS = 1, then these pins assume the function listed in parenthesis ().
15	$\overline{\text{RD}}$ (DS)	I	Read Input (Data Strobe).
16	$\overline{\text{CS}}$	I	Chip Select. Must be low to read or write the port.
17	ALE(AS)	I	Address Latch Enable (Address Strobe). A positive going edge serves to demultiplex the bus.
18	$\overline{\text{WR}}$ (R/ $\overline{\text{W}}$)	I	Write Input (Read/Write).
19	$\overline{\text{INT}}$	O	Alarm Interrupt. Flags host controller during conditions defined in Status Register. Active low, open drain output.
20	V _{DD}	-	Positive Supply. 5.0 volts.
21	V _{SS}	-	Signal Ground. 0.0 volts. Should be tied to local ground plane.
22	LC	I	Load Count. A positive-going edge latches the current bit and bit error count into the user accessible BCR and BECR registers and clears the internal count registers. LC is logically OR'ed with control bit PCR.4. Should be tied to V _{SS} if not used.
23	RLOS	O	Receive Loss Of Sync. Indicates the real time status of the receive synchronizer. Active high output.

PIN	SYMBOL	TYPE	DESCRIPTION
24	RL	I	Receive Load. A positive-going edge loads the previous 32 bits of data received at RDATA into the Pattern Receive Registers. RL is logically OR'ed with control bit PCR.3. Should be tied to V _{SS} if not used.
25	RDATA	I	Receive Data. Received NRZ serial data, sampled on the rising edge of RCLK.
26	RDIS	I	Receive Disable. Set high to prevent the data at RDATA from being sampled. Set low to allow bits at RDATA to be sampled. Should be tied to V _{SS} if not used. See Figure 6 for timing information. All receive side operations are disabled when RDIS is high.
27	RCLK	I	Receive Clock. Input clock from transmission link. 0 to 52 MHz. Can be a gapped clock. Fully independent from TCLK.
28	V _{DD}	-	Positive Supply. 5.0 volts.
29	V _{SS}	-	Signal Ground. 0.0 volts. Should be tied to local ground plane.
30	TCLK	I	Transmit Clock. Transmit demand clock. 0 to 52 MHz. Can be a gapped clock. Fully independent of RCLK.
31	TDIS	I	Transmit Disable. Set high to hold the current bit being transmitted at TDATA. Set low to allow the next bit to appear at TDATA. Should be tied to V _{SS} if not used. See Figure 7 for timing information. All transmit side operations are disabled when TDIS is high.
32	TDATA	O	Transmit Data. Transmit NRZ serial data, updated on the rising edge of TCLK.

DS2172 REGISTER MAP Table 2

ADDRESS	R/W	REGISTER NAME	ADDRESS	R/W	REGISTER NAME
00	R/W	Pattern Set Register 3.	0C	R	Bit Error Counter Register 3.
01	R/W	Pattern Set Register 2.	0D	R	Bit Error Counter Register 2.
02	R/W	Pattern Set Register 1.	0E	R	Bit Error Counter Register 1.
03	R/W	Pattern Set Register 0.	0F	R	Bit Error Counter Register 0.
04	R/W	Pattern Length Register.	10	R	Pattern Receive Register 3.
05	R/W	Polynomial Tap Register.	11	R	Pattern Receive Register 2.
06	R/W	Pattern Control Register.	12	R	Pattern Receive Register 1.
07	R/W	Error Insert Register.	13	R	Pattern Receive Register 0.
08	R	Bit Counter Register 3.	14	R	Status Register.
09	R	Bit Counter Register 2.	15	R/W	Interrupt Mask Register.
0A	R	Bit Counter Register 1.	1C	R/W	Test Register (see note 1)
0B	R	Bit Counter Register 0.			

NOTE:

1. The Test Register must be set to 00 hex to insure proper operation of the DS2172.

2.0 PARALLEL CONTROL INTERFACE

The DS2172 is controlled via a multiplexed bi-directional address/data bus by an external microcontroller or microprocessor. The DS2172 can operate with either Intel or Motorola bus timing configurations. If the BTS pin is tied low, Intel timing will be selected; if tied high, Motorola timing will be selected. All Motorola bus signals are listed in parenthesis (). See the timing diagrams in the A.C. Electrical Characteristics for more details. The multiplexed bus on the DS2172 saves pins because the address information and data information share the same signal paths. The addresses are presented to the pins in the first portion of the bus cycle and data will be transferred on the pins during second portion of the bus cycle. Addresses must be valid prior to the falling edge of ALE(AS), at which time the DS2172 latches the address from the AD0 to AD7 pins. Valid write data must be present and held stable during the later portion of the DS or \overline{WR} pulses. In a read cycle, the DS2172 outputs a byte of data during the latter portion of the DS or \overline{RD} pulses. The read cycle is terminated and the bus returns to a high impedance state as \overline{RD} transitions high in Intel timing or as DS transitions low in Motorola timing. The DS2172 can also be easily connected to non-multiplexed buses. RCLK and TCLK are used to update counters and load transmit and receive pattern registers. At slow clock rates, sufficient time must be allowed for these port operations.

3.0 PATTERN SET REGISTERS

The Pattern Set Registers (PSR) are loaded each time a new pattern (whether it be pseudorandom or repetitive) is to be generated. When a pseudorandom pattern is generated, all four PSRs must be loaded with FF Hex. When a repetitive pattern is to be created, the four PSRs are loaded with the pattern that is to be repeated. Please see Tables 4 and 5 for some programming examples.

PATTERN SET REGISTERS

(MSB)				(LSB)				
PS31	PS30	PS29	PS28	PS27	PS26	PS25	PS24	PSR3 (addr.=00 Hex)
PS23	PS22	PS21	PS20	PS19	PS18	PS17	PS16	PSR2 (addr.=01 Hex)
PS15	PS14	PS13	PS12	PS11	PS10	PS9	PS8	PSR1 (addr.=02 Hex)
PS7	PS6	PS5	PS4	PS3	PS2	PS1	PS0	PSR0 (addr.=03 Hex)

4.0 PATTERN LENGTH REGISTER

Length Bits LB4 to LB0 determine the length of the pseudorandom polynomial or programmable repetitive pattern that is generated and detected. With the pseudorandom patterns, the “Tap A” feedback position of the pattern generator is always equal to the value in the Pattern Length Register (PLR). Please refer to Figure 2 for a block diagram of the pattern generator and to Tables 4 and 5 for some programming examples.

PLR: PATTERN LENGTH REGISTER (Address=04 Hex)

(MSB)								(LSB)
-	-	-	LB4	LB3	LB2	LB1	LB0	

SYMBOL	POSITION	NAME AND DESCRIPTION
--------	----------	----------------------

-	PLR1.7	Not Assigned. Should be set to 0 when written to.
-	PLR1.6	Not Assigned. Should be set to 0 when written to.
-	PLR1.5	Not Assigned. Should be set to 0 when written to.
LB4	PLR1.4	Length Bit 4.
LB3	PLR1.3	Length Bit 3.
LB2	PLR1.2	Length Bit 2.
LB1	PLR1.1	Length Bit 1.
LB0	PLR1.0	Length Bit 0.

5.0 POLYNOMIAL TAP REGISTER

Polynomial Tap Bits PT4 - PT0 determine the feedback position of Tap B connected to the XOR input of the pattern generator. Feedback Tap B provides one of two feedback paths within the pattern generator. Please refer to Figure 2 for a block diagram of the pattern generator and to Tables 4 and 5 for register programming examples.

PTR: POLYNOMIAL TAP REGISTER (Address=05 Hex)

(MSB)								(LSB)
-	-	-	PT4	PT3	PT2	PT1	PT0	

SYMBOL	POSITION	NAME AND DESCRIPTION
--------	----------	----------------------

-	PTR.7	Not Assigned. Should be set to 0 when written to.
-	PTR.6	Not Assigned. Should be set to 0 when written to.
-	PTR.5	Not Assigned. Should be set to 0 when written to.
PT4	PTR.4	Polynomial Tap Bit 4.
PT3	PTR.3	Polynomial Tap Bit 3.
PT2	PTR.2	Polynomial Tap Bit 2.
PT1	PTR.1	Polynomial Tap Bit 1.
PT0	PTR.0	Polynomial Tap Bit 0.

6.0 PATTERN CONTROL REGISTER

The Pattern Control Register (PCR) is used to configure the operating parameters of the DS2172 and to control the patterns being generated and received. Also the PCR is used to control the pattern synchronizer and the error and bit counters.

PCR: PATTERN CONTROL REGISTER (Address=06 Hex)

(MSB)							(LSB)
TL	QRSS	PS	LC	RL	SYNCE	RESYNC	LPBK

SYMBOL	POSITION	NAME AND DESCRIPTION
TL	PCR.7	Transmit Load. A low to high transition loads the pattern generator with the contents of the Pattern Set Registers. PCR.7 is logically ORed with the input pin TL. Must be cleared and set again for subsequent loads.
QRSS	PCR.6	Zero Suppression Select. Forces a 1 into the pattern whenever the next 14 bit positions are all 0s. Should only be set when using the QRSS pattern. 0 = Zero suppression disabled 1 = Zero suppression enabled
PS	PCR.5	Pattern Select. 0 = Repetitive Pattern 1 = Pseudorandom Pattern
LC	PCR.4	Latch Count Registers. A low to high transition latches the bit and error counts into the user accessible registers BCR and BECR and clears the internal register count. PCR.4 is logically OR'ed with input pin LC. Must be cleared and set again for subsequent loads.
RL	PCR.3	Receive Data Load. A transition from low to high loads the previous 32 bits of data received at RDATA into the Pattern Receive Registers (PRR). PCR.3 is logically OR'ed with input pin RL. Must be cleared and set again for subsequent latches.
SYNCE	PCR.2	SYNC Enable. 0 = auto resync is enabled. 1 = auto resync is disabled.
RESYNC	PCR.1	Initiate Manual Resync Process. A low to high transition will force the DS2172 to resynchronize to the incoming pattern at RDATA. Must be cleared and set again for a subsequent resync.
LPBK	PCR.0	Transmit/Receive Loopback Select. When enabled, the RDATA input is disabled; TDATA continues to output data as normal. See Figure 1. 0 = loopback disabled 1 = loopback enabled

7.0 ERROR INSERT REGISTER

The Error Insertion Register (EIR) controls circuitry within the DS2172 that allows the generated pattern to be intentionally corrupted. Bit errors can be inserted automatically at regular intervals by properly programming the EIR0 to EIR2 bits or bit errors can be inserted at random (under microcontroller control) via the EIR.3 bit.

EIR: ERROR INSERT REGISTER (Address=07 Hex)

(MSB)								(LSB)
-	-	TINV	RINV	SBE	EIR2	EIR1	EIR0	

SYMBOL POSITION NAME AND DESCRIPTION

-	EIR.7	Not Assigned. Should be set to 0 when written to.
-	EIR.6	Not Assigned. Should be set to 0 when written to.
TINV	EIR.5	Transmit Data Inversion Select. 0 = do not invert data to be transmitted at TDATA 1 = invert data to be transmitted at TDATA
RINV	EIR.4	Receive Data Inversion Select. 0 = do not invert data received at RDATA 1 = invert data received at RDATA
SBE	EIR.3	Single Bit Error Insert. A low to high transition will create a single bit error. Must be cleared and set again for a subsequent bit error to be inserted. Can be used to accomplish rates not addressed in Table 3 (e.g., BER of less than 10^{-7}).
EIB2	EIR.2	Error Insert Bit 2. See Table 3.
EIB1	EIR.1	Error Insert Bit 1. See Table 3.
EIB0	EIR.0	Error Insert Bit 0. See Table 3.

ERROR BIT INSERTION Table 3

EIB2	EIB1	EIB0	ERROR RATE INSERTED
0	0	0	no errors automatically inserted
0	0	1	10^{-1}
0	1	0	10^{-2}
0	1	1	10^{-3}
1	0	0	10^{-4}
1	0	1	10^{-5}
1	1	0	10^{-6}
1	1	1	10^{-7}

PSEUDORANDOM PATTERN GENERATION (PCR.5=1) Table 4

PATTERN TYPE	PTR	PLR	PSR3	PSR2	PSR1	PSR0	TINV	RINV
$2^3 - 1$	00	02	FF	FF	FF	FF	0	0
$2^4 - 1$	00	03	FF	FF	FF	FF	0	0
$2^5 - 1$	01	04	FF	FF	FF	FF	0	0
$2^6 - 1$	04	05	FF	FF	FF	FF	0	0
$2^7 - 1$	00	06	FF	FF	FF	FF	0	0
$2^7 - 1$ Fractional T1 LB Activate	03	06	FF	FF	FF	FF	0	0
$2^7 - 1$ Fractional T1 LB Deactivate	03	06	FF	FF	FF	FF	1	1
$2^9 - 1$ O.153 (511 type)	04	08	FF	FF	FF	FF	0	0
$2^{10} - 1$	02	09	FF	FF	FF	FF	0	0
$2^{11} - 1$ O.152 and O.153 (2047 type)	08	0A	FF	FF	FF	FF	0	0
$2^{15} - 1$ O.151	0D	0E	FF	FF	FF	FF	1	1
$2^{17} - 1$	02	10	FF	FF	FF	FF	0	0
$2^{18} - 1$	06	11	FF	FF	FF	FF	0	0
$2^{20} - 1$ O.153	02	13	FF	FF	FF	FF	0	0
$2^{20} - 1$ O.151 QRSS (PCR.6=1)	10	13	FF	FF	FF	FF	0	0
$2^{21} - 1$	01	14	FF	FF	FF	FF	0	0
$2^{22} - 1$	00	15	FF	FF	FF	FF	0	0
$2^{23} - 1$ O.151	11	16	FF	FF	FF	FF	1	1
$2^{25} - 1$	02	18	FF	FF	FF	FF	0	0
$2^{28} - 1$	02	1B	FF	FF	FF	FF	0	0
$2^{29} - 1$	01	1C	FF	FF	FF	FF	0	0
$2^{31} - 1$	02	1E	FF	FF	FF	FF	0	0
$2^{32} - 1$ (see note below)	10	1F	FF	FF	FF	FF	0	0

REPETITIVE PATTERN GENERATION (PCR.5=0) Table 5

PATTERN TYPE	PTR	PLR	PSR3	PSR2	PSR1	PSR0	TINV	RINV
all 1s	00	00	FF	FF	FF	FF	0	0
all 0s	00	00	FF	FF	FF	FE	0	0
alternating 1s and 0s	00	01	FF	FF	FF	FE	0	0
double alternating 1s and 0s	00	03	FF	FF	FF	FC	0	0
3 in 24	00	17	FF	20	00	22	0	0
1 in 16	00	0F	FF	FF	00	01	0	0
1 in 8	00	07	FF	FF	FF	01	0	0
1 in 4	00	03	FF	FF	FF	F1	0	0
D4 Line Loopback Activate	00	04	FF	FF	FF	F0	0	0
D4 Line Loopback Deactivate	00	02	FF	FF	FF	FC	0	0

NOTES FOR TABLES 4 AND 5:

1. PTR = Polynomial Tap Register (address = 05)
2. PLR = Pattern Length Register (address = 04)
3. PSR3 = Pattern Set Register 3 (address = 00)
4. PSR2 = Pattern Set Register 2 (address = 01)
5. PSR1 = Pattern Set Register 1 (address = 02)
6. PSR0 = Pattern Set Register 0 (address = 03)
7. TINV = Transmit Data Inversion Select Bit (EIR.5)
8. RINV = Receive Data Inversion Select Bit (EIR.4)
9. For the $2^{32} - 1$ pattern, the random pattern actually repeats every $(4093 \times 2^{20}) + 1046529$ bits instead of $2^{32} - 1$.

8.0 BIT COUNT REGISTERS

The Bit Count Registers (BCR3 to BCR0) comprise a 32-bit count of bits (actually RCLK cycles) received at RDATA. BC31 is the MSB of the 32-bit count. The bit counter increments for each cycle of RCLK when input pin RDIS is low. The bit counter is disabled during loss of SYNC. The Status Register bit BCOF is set when this 32-bit register overflows. Upon an overflow condition, the user must clear the BCR by either toggling the LC bit or pin. The DS2172 latches the bit count into the BCR registers and clears the internal bit count when either the PCR.4 bit or the LC input pin toggles from low to high. The bit count and bit error count (available via the BECRs) are used by an external processor to compute the BER performance on a loop or channel basis.

BIT COUNT REGISTERS

(MSB)				(LSB)				
BC31	BC30	BC29	BC28	BC27	BC26	BC25	BC24	BCR3 (addr.=08 Hex)
BC23	BC22	BC21	BC20	BC19	BC18	BC17	BC16	BCR2 (addr.=09 Hex)
BC15	BC14	BC13	BC12	BC11	BC10	BC9	BC8	BCR1 (addr.=0A Hex)
BC7	BC6	BC5	BC4	BC3	BC2	BC1	BC0	BCR0 (addr.=0B Hex)

9.0 BIT ERROR COUNT REGISTERS

The Bit Error Count Registers (BECR3 to BECR0) comprise a 32-bit count of bits received in error at RDATA. The bit error counter is disabled during loss of SYNC. BEC31 is the MSB of the 32-bit count. The Status Register bit BECOF is set when this 32-bit register overflows. Upon an overflow condition, the user must clear the BECR by either toggling the LC bit or pin. The DS2172 latches the bit error count into the BECR registers and clears the internal bit error count when either the PCR.4 bit or the LC input pin toggles from low to high. The bit count (available via the BCRs) and bit error count are used by an external processor to compute the BER performance on a loop or channel basis.

BIT ERROR COUNT REGISTERS

(MSB)				(LSB)				
BEC31	BEC30	BEC29	BEC28	BEC27	BEC26	BEC25	BEC24	BECR3 (addr.=0C Hex)
BEC23	BEC22	BEC21	BEC20	BEC19	BEC18	BEC17	BEC16	BECR2 (addr.=0D Hex)
BEC15	BEC14	BEC13	BEC12	BEC11	BEC10	BEC9	BEC8	BECR1 (addr.=0E Hex)
BEC7	BEC6	BEC5	BEC4	BEC3	BEC2	BEC1	BEC0	BECR0 (addr.=0F Hex)

10.0 PATTERN RECEIVE REGISTERS

The Pattern Receive Register (PRR) provides access to the data patterns received at RDATA. The operation of these registers depends on the synchronization status of the DS2172. Asserting the RL bit (PCR.3) or pin during an out-of -sync condition (SR.0 = 0) will latch the previous 32 bits of data received at RDATA into the PRR registers. When the DS2172 is in sync (SR.0 = 1) asserting RL will latch the pattern that to which the device has established synchronization. Since the receiver has no knowledge of the start or end of the pattern, the data in the PRR registers will have no particular alignment. As an example, if the receiver has synchronized to the pattern 00100110, PRR1 may report 10011000, 11000100 or any rotation thereof. Once synchronization is established, bit errors cannot be viewed in the PRR registers.

PATTERN RECEIVE REGISTERS

(MSB)				(LSB)				
PR31	PR30	PR29	PR28	PR27	PR26	PR25	PR24	PRR3 (addr.=10 Hex)
PR23	PR22	PR21	PR20	PR19	PR18	PR17	PR16	PRR2 (addr.=11 Hex)
PR15	PR14	PR13	PR12	PR11	PR10	PR9	PR8	PRR1 (addr.=12 Hex)
PR7	PR6	PR5	PR4	PR3	PR2	PR1	PR0	PRR0 (addr.=13 Hex)

11.0 STATUS REGISTER AND INTERRUPT MASK REGISTER

The Status Register (SR) contains information on the current real time status of the DS2172. When a particular event has occurred, the appropriate bit in the register will be set to a 1. All of the bits in these registers (except for the SYNC bit) operate in a latched fashion. This means that if an event occurs and a bit is set to a 1 in any of the registers, it will remain set until the user reads that bit. For the BED, BCOF, and BECOF status bits, they will be cleared when read and will not be set again until the event has occurred again. For RLOS, RA0, and RA1 status bits, they will be cleared when read if the condition no longer persists.

The SR register has the unique ability to initiate a hardware interrupt via the $\overline{\text{INT}}$ pin. Each of the alarms and events in the SR can be either masked or unmasked from the interrupt pins via the Interrupt Mask Register (IMR).

SR: STATUS REGISTER (Address=14 Hex)

(MSB)							(LSB)
-	RA1	RA0	RLOS	BED	BCOF	BECOF	SYNC

SYMBOL	POSITION	NAME AND DESCRIPTION
-	SR.7	Not Assigned. Could be any value when read.
RA1	SR.6	Receive All Ones. Set when 32 consecutive 1s are received; allowed to be cleared when a 0 is received.
RA0	SR.5	Receive All Zeros. Set when 32 consecutive 0s are received; allowed to be cleared when a 1 is received.
RLOS	SR.4	Receive Loss Of Sync. Set when the device is searching for synchronization. Once sync is achieved, will remain set until read.
BED	SR.3	Bit Error Detection. Set when bit errors are detected.
BCOF	SR.2	Bit Counter Overflow. Set when the 32-bit BCR overflows.
BECOF	SR.1	Bit Error Count Overflow. Set when the 32-bit BECR overflows.
SYNC	SR.0	Sync. Real time status of the synchronizer (this bit is not latched). Will be set when synchronization is declared. Will be cleared when 6 or more bits out of 64 are received in error (if PCR.2 = 0).

IMR: INTERRUPT MASK REGISTER (Address=15 Hex)

(MSB)							(LSB)
-	RA1	RA0	RLOS	BED	BCOF	BECOF	SYNC

SYMBOL	POSITION	NAME AND DESCRIPTION
-	IMR.7	Not Assigned. Should be set to 0 when written to.
RA1	IMR.6	Receive All 1s. 0 = interrupt masked 1 = interrupt enabled
RA0	IMR.5	Receive All 0s. 0 = interrupt masked 1 = interrupt enabled
RLOS	IMR.4	Receive Loss Of Sync. 0 = interrupt masked 1 = interrupt enabled
BED	IMR.3	Bit Error Detection. 0 = interrupt masked 1 = interrupt enabled
BCOF	IMR.2	Bit Counter Overflow. 0 = interrupt masked 1 = interrupt enabled
BECOF	IMR.1	Bit Error Count Overflow. 0 = interrupt masked 1 = interrupt enabled
SYNC	IMR.0	Sync. 0 = interrupt masked 1 = interrupt enabled

12.0 AC TIMING AND DC OPERATING CHARACTERISTICS

ABSOLUTE MAXIMUM RATINGS*

Voltage on Any Pin Relative to Ground	-1.0V to +7.0V
Operating Temperature	0°C to 70°C
Storage Temperature	-55°C to +125°C
Soldering Temperature	260°C for 10 seconds

* This is a stress rating only and functional operation of the device at these or any other conditions above those indicated in the operation sections of this specification is not implied. Exposure to absolute maximum rating conditions for extended periods of time may affect reliability.

RECOMMENDED DC OPERATING CONDITIONS (0°C to 70°C)

PARAMETER	SYMBOL	MIN	TYP	MAX	UNITS	NOTES
Logic 1	V_{IH}	2.0		$V_{DD}+0.3$	V	
Logic 0	V_{IL}	-0.3		+0.8	V	
Supply	V_{DD}	4.50		5.50	V	

CAPACITANCE ($t_A=25^\circ\text{C}$)

PARAMETER	SYMBOL	MIN	TYP	MAX	UNITS	NOTES
Input Capacitance	C_{IN}		5		pF	
Output Capacitance	C_{OUT}		7		pF	

DC CHARACTERISTICS (0°C to 70°C; $V_{DD}=5V \pm 10\%$)

PARAMETER	SYMBOL	MIN	TYP	MAX	UNITS	NOTES
Supply Current @ 5V	I_{DD}		10		mA	1
Input Leakage	I_{IL}	-1.0		+1.0	μA	2
Output Leakage	I_{LO}			1.0	μA	3
Output Current @ 2.4V	I_{OH}	-1.0			mA	
Output Current @ 0.4V	I_{OL}	+4.0			mA	

NOTES:

1. TCLK = RCLK = 1.544 MHz; outputs open circuited.
2. $0.0V < V_{IN} < V_{DD}$.
3. Applies to $\overline{\text{INT}}$ when tri-stated.

AC CHARACTERISTICS - PARALLEL PORT (0°C to 70°C; $V_{DD}=5V \pm 10\%$)

PARAMETER	SYMBOL	MIN	TYP	MAX	UNITS	NOTES
Cycle Time	t_{CYC}	200			ns	
Pulse Width, DS Low or \overline{RD} High	PW_{EL}	100			ns	
Pulse Width, DS High or \overline{RD} Low	PW_{EH}	100			ns	
Input Rise/Fall Times	t_R, t_F			20	ns	
R/ \overline{W} Hold Times	t_{RWH}	10			ns	
R/ \overline{W} Setup Time Before DS High	t_{RWS}	50			ns	
\overline{CS} Setup Time Before DS, \overline{WR} or \overline{RD} Active	t_{CS}	20			ns	
\overline{CS} Hold Time	t_{CH}	0			ns	
Read Data Hold Time	t_{DHR}	5		50	ns	
Write Data Hold Time	t_{DHW}	0			ns	
Mux'ed Address Valid to AS or ALE Fall	t_{ASL}	15			ns	
Mux'ed Address Hold Time	t_{AHL}	10			ns	
Delay Time DS, \overline{WR} or \overline{RD} to AS or ALE Rise	t_{ASD}	20			ns	
Pulse Width AS or ALE High	PW_{ASH}	30			ns	
Delay Time, AS or ALE to DS, \overline{WR} or \overline{RD}	t_{ASED}	10			ns	
Output Data Delay Time from DS or \overline{RD}	t_{DDR}	5		50	ns	
Data Setup Time	t_{DSW}	50			ns	

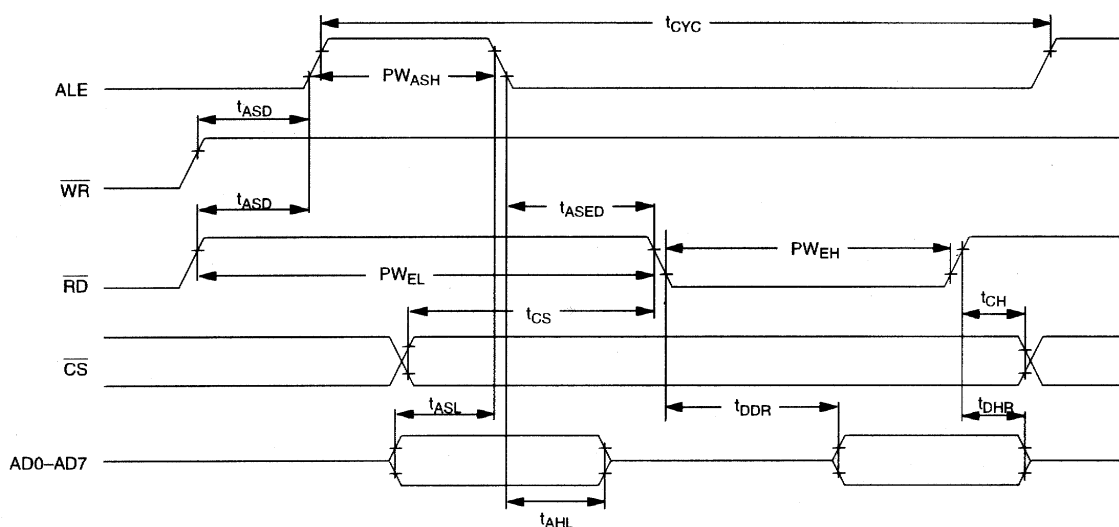
INTEL BUS READ AC TIMING (BTS=0) Figure 3

INTEL BUS WRITE AC TIMING (BTS=0) Figure 4

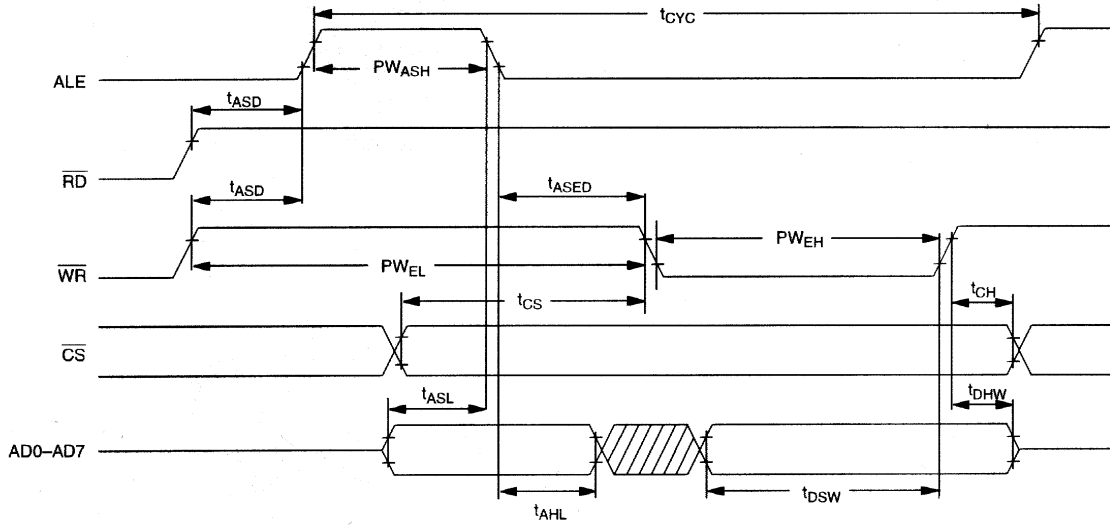

MOTOROLA BUS AC TIMING (BTS=1) Figure 5

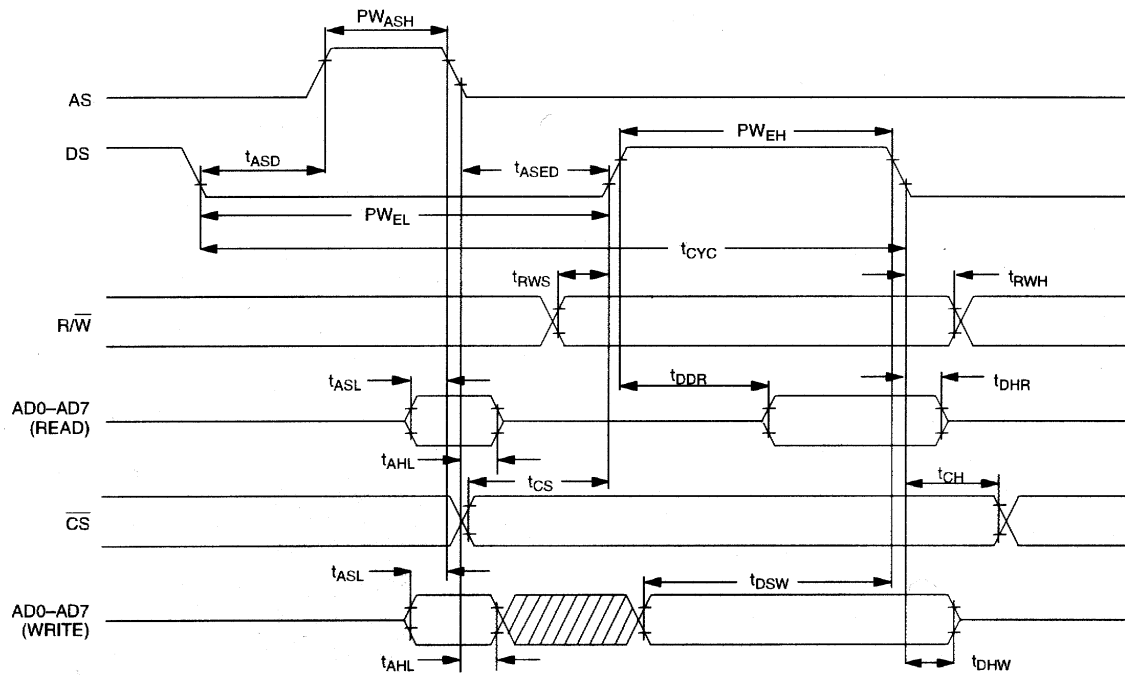

AC CHARACTERISTICS - RECEIVE SIDE (0°C to 70°C; $V_{DD}=5V \pm 10\%$)

PARAMETER	SYMBOL	MIN	TYP	MAX	UNITS	NOTES
RCLK Period	t_{CP}	19			ns	
RCLK Pulse Width	t_{CH}	8			ns	
	t_{CL}	8			ns	
RDATA Set Up to RCLK Rising	t_{SU1}	4			ns	
RDATA Hold from RCLK Rising	t_{HD1}	0			ns	
RDIS Set Up to RCLK Rising	t_{SU2}	4			ns	
RDIS Hold from RCLK Rising	t_{HD2}	0			ns	
RL and LC Pulse Width	t_{WRL}	25			ns	
RCLK Rise and Fall Times	t_R, t_F			10	ns	1

AC CHARACTERISTICS - TRANSMIT SIDE (0°C to 70°C; $V_{DD}=5V \pm 10\%$)

PARAMETER	SYMBOL	MIN	TYP	MAX	UNITS	NOTES
TCLK Period	t_{CP}	19			ns	
TCLK Pulse Width	t_{CH}	8			ns	
	t_{CL}	8			ns	
TDATA Delay from TCLK Rising	t_{DD}			9	ns	
TDIS Set Up to TCLK Rising	t_{SU}	4			ns	
TDIS Hold from TCLK Rising	t_{HD}	0			ns	
TL Pulse Width	t_{WTL}	15			ns	
TL Set Up to TCLK Rising	t_{STL}	4			ns	
TL Hold Off from TCLK Rising	t_{HTL}	0			ns	
TCLK Rise and Fall Time	t_R, t_F			10	ns	1

NOTE:

1. The maximum rise and fall time is either 10 ns or 10% of t_{CP} whichever is less.

RECEIVE AC TIMING Figure 6

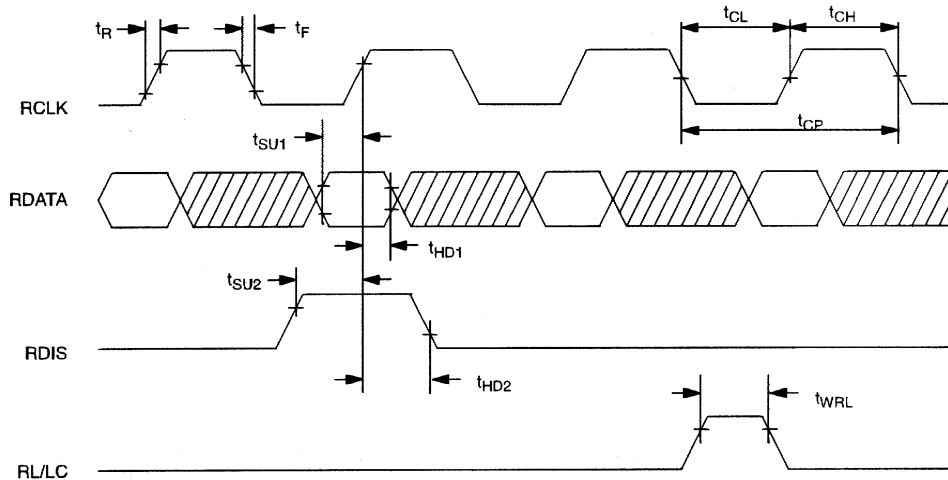

TRANSMIT AC TIMING Figure 7

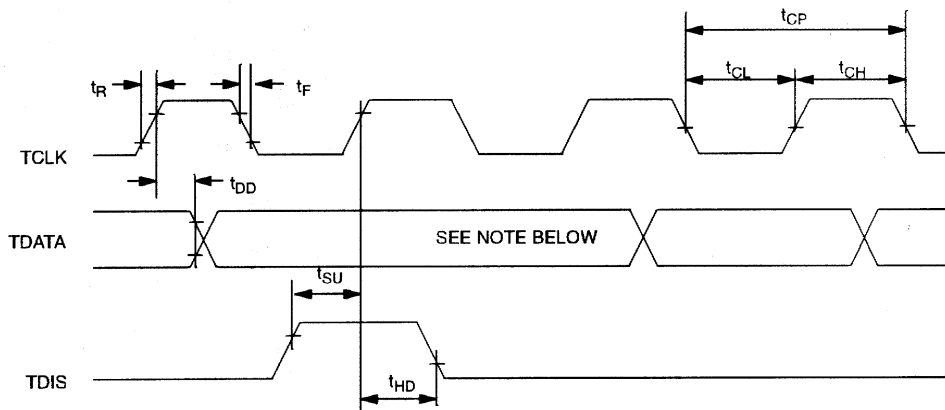

NOTE: When TDIS is high about the rising edge of TCLK, TDATA will not be updated and will be held with the previous value until TDIS is low about the rising edge of TCLK.

TRANSMIT AC TIMING FOR THE TL INPUT Figure 8

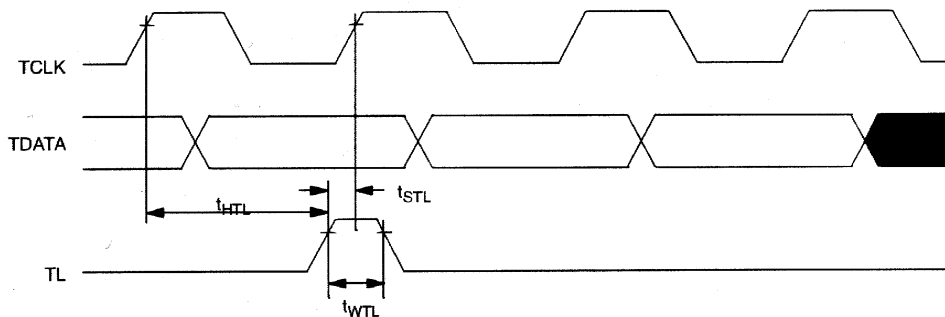

NOTE: The rising edge of TL causes the internal pattern generation circuitry to be reloaded; the first bit of the new pattern (the shaded one) will appear after two TCLK periods.

DS2172 32-PIN TQFP

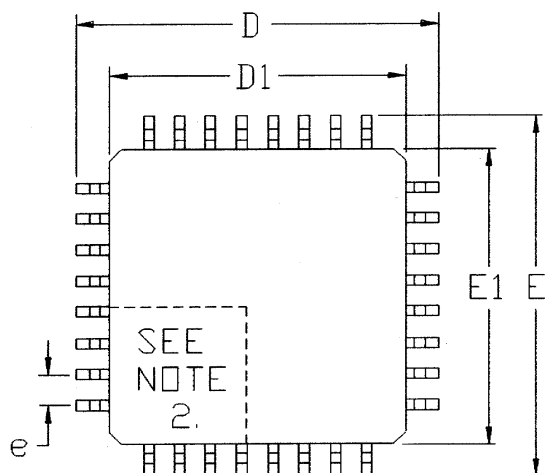

SEE DETAIL "A"

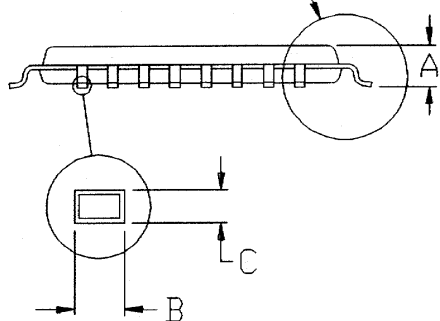

NOTES:

1. DIMENSIONS D1 AND E1 INCLUDE MOLD MISMATCH, BUT DO NOT INCLUDE MOLD PROTRUSION; ALLOWABLE PROTRUSION IS 0.25 MM PER SIDE.
2. DETAILS OF PIN 1 IDENTIFIER ARE OPTIONAL BUT MUST BE LOCATED WITHIN THE ZONE INDICATED.
3. ALLOWABLE DAMBAR PROTRUSION IS 0.08 MM TOTAL IN EXCESS OF THE B DIMENSION; AT MAXIMUM MATERIAL CONDITION. PROTRUSION NOT TO BE LOCATED ON LOWER RADIUS OR FOOT OF LEAD.
4. CONTROLLING DIMENSIONS: MILLIMETERS.

DIM	MIN	MAX
A	-	1.20
A1	0.05	0.15
A2	0.95	1.05
D	8.80	9.20
D1	7.00 BSC	
E	8.80	9.20
E1	7.00 BSC	
L	0.45	0.75
e	0.80 BSC	
B	0.30	0.45
C	0.09	0.20

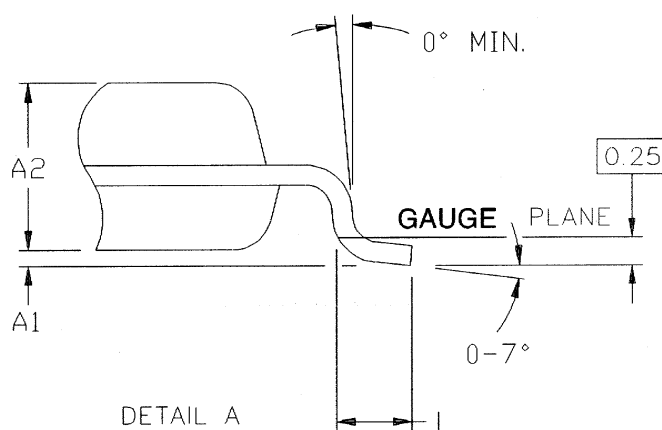

DIMENSIONS ARE IN MILLIMETERS