



# DS1676 Total Elapsed Time Recorder, Erasable

[www.dalsemi.com](http://www.dalsemi.com)

## FEATURES

- Records the total time that the Event Input has been active and the number of events that have occurred.
- Volatile Elapsed Time Counter to monitor event durations with quarter second resolution
- Built in 32-bit non-volatile Total Time Accumulator Register (34 years.)
- Non-volatile 17-bit Event Counter records the total number of times an event has occurred.
- Reset Enable pin allows the Total Time Accumulator and Event Counter to be reset back to zero if desired via the 2-wire interface.
- Calibrated, Temperature Compensated, RC time base (accurate to 1% typ.)
- Stores the contents of the Elapsed Time Counter with the previous total and increments the event counter at the end of each event or power down.
- 10-bytes of write protectable EEPROM user memory.
- Write Disable bit to prevent the memory from being changed or erased.
- Anti-Glitch filter will prevent noise spikes from triggering false events on the Event Input.
- 2-Wire serial communication.
- Wide power supply range (2.7V – 5.5V)

## PIN ASSIGNMENT

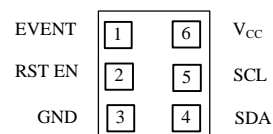

Bottom View

DS1676X 6-pin Flip Chip

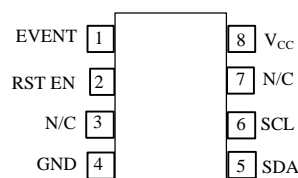

Top View

DS1676 8-Pin  $\mu$ SOP  
DS1676S 8-Pin SOIC (150 mil)

## PIN DESCRIPTION

EVENT	- Event Input
RST EN	- Reset Enable Input
GND	- Ground
SDA	- 2-Wire Data Input/Output
SCL	- 2-Wire Clock Input
Vcc	- Voltage Supply
N/C	- No Connect

## ORDERING INFORMATION

DS1676	8-Pin $\mu$ SOP
DS1676S	8-Pin SOIC (150 mil)
DS1676X	6-Pin FLIP CHIP PACKAGE

\*\*For more information of Flip Chip Packaging, go to [www.dalsemi.com](http://www.dalsemi.com) to the Released Data Sheets section and select [Chip Scale and Flip Chip Package Data Index](#)

## DESCRIPTION

The DS1676 is an integrated elapsed time recorder that will provide the total amount of time that an event is/has been active since the DS1676 was last reset to zero via the 2-wire bus. This is ideal for applications such as monitoring the total amount of time that something is turned on or in operation, how long something has been used, or the total number of uses since the last calibration or repair.

The DS1676 uses a calibrated, temperature compensated, RC time base to increment an elapsed time counter while an event is active. When the event becomes active, the contents of the non-volatile Total Time Accumulator register are downloaded to the Elapsed Time Counter (ETC) and as the event continues, the ETC is incremented in quarter second increments. When the event becomes inactive or the power is removed, the DS1676 will increment the 17-bit non-volatile Event Counter register and put the contents of the ETC into the 32-bit non-volatile Total Accumulated Time register which can hold up to 34 years of active event time. A storage cap may be required on  $V_{CC}$  to provide enough power to store the value in the ETC to the Total Time Accumulator register if power is taken away at the same time the event ends.

There is no way for this device to be reset if the Reset Enable pin is held low. With the Reset Enable pin high, the DS1676 can be reset by the Reset command sent over the 2-wire bus. If a switch or button is used to control the polarity of the Reset Enable pin, a debounce capacitor should be used to prevent spikes on the input.

The Write Memory Disable is used to control the writability of the 10 bytes of EEPROM User memory. The Write Memory Disable Flag is set to a 1 when the Write Memory Disable command is written twice and can not be changed once it is set to a 1. If the Write Memory Disable flag is set to a 1, the 10 bytes of memory will not be able to be written or erased. If the Write Memory Disable flag is a 0, the user will have full access to the bytes with the standard EEPROM write time restrictions.

When data is written to the device, the device slave address will be sent first followed by the address pointer and the desired byte of data. Once a single byte of data is sent, there must be at least a 20 mS to allow the EEPROM to update the data.

## OVERVIEW

The block diagram in Figure 1 shows the relationship between the major control and memory I/O sections of the DS1676. The device has three major components: 1) clock generator and control blocks, 2) elapsed time counter and accumulator registers, and 3) 2-wire interface.

### DS1676 Block Diagram Figure 1

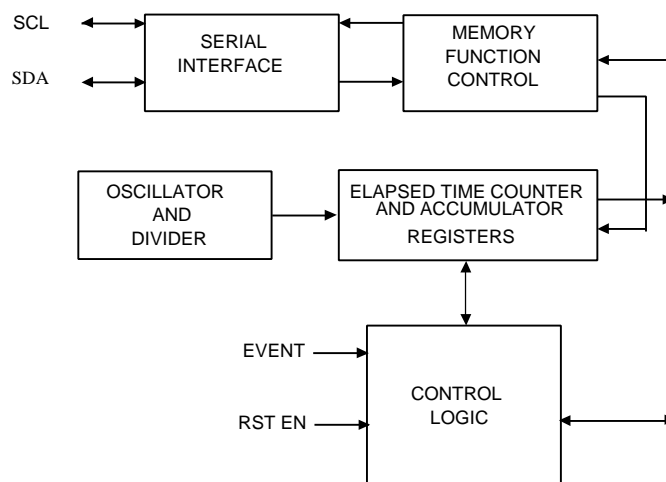

## SIGNAL DESCRIPTIONS

The following paragraphs describe the function of each pin.

**V<sub>CC</sub> – V<sub>CC</sub>** is a +3-5V input supply. A capacitor or other temporary energy source may be required to hold the Voltage 100 mS after the event has completed if the system power is removed at the same time as the event ends in order to allow the contents of the ETC to be stored properly. With less than the 100 mS of power after the end of the event, the new data may be lost. The LSB is written first to be sure that the most likely changed data is saved first.

**GND** - Ground

**SCL** (2-Wire Serial Clock Input) – The SCL pin is the serial clock input for the 2-wire synchronous communications channel. The SCL pin is an open drain input, which requires an external pull-up resistor.

**SDA** (2-Wire Input/Output) – The SDA pin is the data Input/Output signal for the 2-wire synchronous communications channel. The SDA pin is an open drain I/O, which requires an external pull-up resistor.

**EVENT** (Event Interrupt Input) – The Event pin is an input that will be activated by an external device to signify an event has occurred and should be logged. When the pin is pulled high, the Elapsed Time Counter (ETC) will begin to keep track of the time with quarter second resolution and when the pin is pulled low, the contents of the ETC will be stored in the non-volatile Total Time Accumulator register and the Event Counter register will be incremented. A pull-down resistor has been internally connected to the Event input to prevent power-up glitches from triggering a false event. The Event input has a Glitch filter to prevent very short noise spikes from triggering an event. A capacitor or other temporary energy source may be required to hold the Voltage 100 mS after the event has completed if the system power is removed at the same time as the event ends in order to allow the contents of the ETC to be stored properly. With less than the 100 mS of power after the end of the event, the data may be lost. The LSB is written first to be sure that the most likely changed data is saved first. When the Event pin changes states, the 2-wire bus will be unavailable for communications for 200 mS.

**RST EN** (Reset Enable Input) – The Reset Enable pin allows the D1676 to accept the Reset command via the 2-wire bus to clear the Total Time Accumulator and Event Counter if the Reset Enable pin is pulled high. If the Reset Enable pin is pulled low, the DS1676 will not respond to the 2-wire command to reset the Total Time Accumulator register or the Event Counter to zero. This pin allows the designer to permanently enable the reset function, enable the function during the manufacturing process and then disable it, or turn it on and off when the authorized repair person has completed repairing or calibrating the equipment. There is no security provided to this pin to prevent someone from enabling the reset function at any time by pulling the pin high. The security will have to be provided by the system and/or enclosure, if required. If a switch or button is used to control the polarity of the Reset Enable pin, a debounce capacitor should be used to prevent spikes on the input.

**N/C** (No Connect) – This pin is not connected internally.

**MEMORY MAP**

Addr	Bit 7	Bit 6	Bit 5	Bit 4	Bit 3	Bit 2	Bit 1	Bit 0	Function
00	0	0	1	WMDF	0	0	0	ERO	Config Reg
01	Not Used (reads 00h)								Not Used
02									
03									
04									
05	Low Byte Middle Byte High Byte								Total Time Accumulator
06									
07									
08									
09	Low Byte High Byte								Event Counter
0A									
0B	User Memory								
0C									
0D									
0E									
0F									
10									
11									
12									
13									
14									
15	Not Used (reads 00h)								Not Used
16									
17									
18									
19									
1A									
1B									
1C									
1D									
1E									
1F	Write Memory Disable								Mem Disable

**DATA LOGGING**

When the DS1675 is powered-up, the contents of the Total Time Accumulate register (TTA) are downloaded to the ETC and the device begins looking for events that trigger the Event input. When an event triggers the input by transitioning to a high level input, the ETC begins incrementing in quarter second resolution. When the Event input falls below  $0.5 \cdot V_{CC}$  to indicate the end of an Event, a power failure or power-down, the contents of the ETC are stored in the non-volatile Total Time Accumulator register, the Event Counter register is incremented and the ETC is prepared for the next event. There is a built in pull-down on the Event input to prevent power-up glitches from triggering a false event.

The ETC will not roll over to 0000h once FFFFh is reached. The DS1675 will stop counting time once FFFFh is reached. This should take approximately 34 years with the event pin pulled high. When the Event pin is pulled high, the 2-wire bus is not available for communications.

## CLOCK

The clock circuitry consists of a calibrated, temperature compensated, RC time base and a 32-bit Elapsed Time Counter (ETC) which increments on the quarter second. The total time of all events is stored in the non-volatile Total Time Accumulator register.

## TOTAL TIME ACCUMULATOR REGISTER

The Total Time Accumulator register is an EEPROM based 32-bit register that holds the total “ON” time of all events up to a total of about 34 years worth of events. This value is not erasable when the Reset pin is pulled low and does not require a power source to insure the data’s integrity. This register can only be cleared when the Reset Enable pin is pulled high and the Reset command is sent via the 2-wire bus. A capacitor or other temporary energy source may be required to hold the Voltage 100 mS after the event has completed if the system power is removed at the same time as the event ends in order to allow the contents of the ETC to be stored properly. With less than the 100 mS of power after the end of the event, the data may be lost. The LSB is written first to be sure that the most likely changed data is saved first.

## EVENT COUNTER REGISTER

This 17-bit register set provides the total number of data samples that have been logged during the life of the product up to 131,072 separate events. The Event Counter consists of 2-bytes of memory in the memory map and the MSb being the Event Roll Over flag in the Control Register. The Event Roll Over bit is set to a 1 the first time that the two byte Event Counter reaches FFh and rolls over to 00h. Once the Event Roll Over bit is set to a 1 and the Event Counter reaches FFh, event counting will stop and the event counter will not roll over to 00h again. This value is not erasable when the Reset Enable pin is pulled low and does not require a power source to maintain the contents to insure the data’s integrity. This register can only be cleared when the Reset Enable pin is pulled high and the Reset command is sent via the 2-wire bus.

## RESET COMMAND

The DS1676 can only be reset when the Reset Enable pin is pulled high, and the Reset command is sent via the 2-wire bus. With the Reset Enable pin pulled low, the Reset command is ignored by the DS1675. The reset command with the Reset Enable pin pulled high will erase the contents of the Elapsed Time Counter, Total Time Accumulator, and Event Counter. The Reset Command will always read 0 if the memory location is read by the user. The DS1682 has an internal Reset Enable bit in the Control register that works like the Reset Enable pin to enable the Reset command to be accepted by the device and clear the registers.

## CONTROL REGISTER

MSb

LSb

0	0	0	WMDF	0	X	0	ERO
---	---	---	------	---	---	---	-----

**WMDF** – Write Memory Disable Flag – When the Write Memory Disable command is written to ??? twice, the WMDF will be set to a 1 and will not be able to be reset or cleared. Once the WMDF is set to a 1, the 10 byte User Memory will become read-only. When the WMDF is a 0, the User Memory will function like normal EEPROM.

**ERO** – Event Counter Roll Over – The ERO bit acts like the 17<sup>th</sup> bit of the Event Counter. When the Event Counter reaches FFh the first time, the next event will cause the ERO to transition from a 0 to a 1 and the Event Counter will roll over to 00h. Once the ERO is set to a 1, the Event Counter will not roll over again. The Event Counter will stop counting events when the ERO is set to 1 and the Event Counter is set to FFh.

## WRITE MEMORY DISABLE

Write Memory Disable – This register when written two times consecutively to 0000 will disable the ability to write to the 10-bytes of User memory. Once the Write Memory Disable register is written to 0000, it can not be reset to 0000 to allow writing to the User memory and the memory is permanently disabled from future writes. The memory becomes Read-Only.

## GLITCH CONTROL CIRCUIT

The DS1682 has a built in glitch control circuit to prevent input noise on the EVENT pin from triggering false events or corrupting the data.

## USER MEMORY

There are 10-bytes of user programmable, EEPROM memory. Once the Write Memory Disable flag is set to a one, the memory can not be erased or written to again. This is good for locating serial numbers, manufacture dates, warrantee information, or other important information. With the Write Memory Disable flag set to a 0, the user memory is readable, writable and erasable.

## SERIAL INTERFACE

The DS1676 provides two-wire serial communications.

## 2-WIRE SERIAL DATA BUS

The DS1676 supports a bi-directional two-wire bus and data transmission protocol. A device that sends data onto the bus is defined as a transmitter, and a device receiving data as a receiver. The device that controls the message is called a "master". The devices that are controlled by the master are "slaves". The bus must be controlled by a master device which generates the serial clock (SCL), controls the bus access, and generates the START and STOP conditions. The DS1676 operates as a slave on the two-wire bus. Connections to the bus are made via the open-drain I/O lines SDA and SCL.

The following bus protocol has been defined (See Figure 2):

- Data transfer may be initiated only when the bus is not busy.
- During data transfer, the data line must remain stable whenever the clock line is HIGH. Changes in the data line while the clock line is high will be interpreted as control signals.

Accordingly, the following bus conditions have been defined:

**Bus not busy:** Both data and clock lines remain HIGH.

**Start data transfer:** A change in the state of the data line, from HIGH to LOW, while the clock is HIGH, defines a START condition.

**Stop data transfer:** A change in the state of the data line, from LOW to HIGH, while the clock line is HIGH, defines the STOP condition.

**Data valid:** The state of the data line represents valid data when, after a START condition, the data line is stable for the duration of the HIGH period of the clock signal. The data on the line must be changed during the LOW period of the clock signal. There is one clock pulse per bit of data.

Each data transfer is initiated with a START condition and terminated with a STOP condition. The number of data bytes transferred between START and STOP conditions is not limited, and is determined by the master device. The information is transferred byte-wise and each receiver acknowledges with a ninth bit. Within the bus specifications a regular mode (100kHz clock rate) and a fast mode (400kHz clock rate) are defined. The DS1676 only supports the standard mode of operations.

**Acknowledge:** Each receiving device, when addressed, is obliged to generate an acknowledge after the reception of each byte. The master device must generate an extra clock pulse which is associated with this acknowledge bit.

A device that acknowledges must pull down the SDA line during the acknowledge clock pulse in such a way that the SDA line is stable LOW during the HIGH period of the acknowledge related clock pulse. Of course, setup and hold times must be taken into account. A master must signal an end of data to the slave by not generating an acknowledge bit on the last byte that has been clocked out of the slave. In this case, the slave must leave the data line HIGH to enable the master to generate the STOP condition.

Depending upon the state of the R/W\* bit, two types of data transfer are possible:

1. Data transfer from a master transmitter to a slave receiver. The first byte transmitted by the master is the slave address. Next follows a number of data bytes. The slave returns an acknowledge bit after each received byte.
2. Data transfer from a slave transmitter to a master receiver. The first byte (the slave address) is transmitted by the master. The slave then returns an acknowledge bit. Next follows a number of data bytes transmitted by the slave to the master. The master returns an acknowledge bit after all received bytes other than the last byte. At the end of the last received byte, a 'not acknowledge' is returned.

The master device generates all of the serial clock pulses and the START and STOP conditions. A transfer is ended with a STOP condition or with a repeated START condition. Since a repeated START condition is also the beginning of the next serial transfer, the bus will not be released.

The DS1676 may operate in the following two modes:

1. Slave receiver mode: Serial data and clock are received through SDA and SCL. After each byte is received, an acknowledge bit is transmitted. START and STOP conditions are recognized as the beginning and end of a serial transfer. Address recognition is performed by hardware after reception of the slave address and direction bit.
2. Slave transmitter mode: The first byte is received and handled as in the slave receiver mode. However, in this mode, the direction bit will indicate that the transfer direction is reversed. Serial data is transmitted on SDA by the DS1676 while the serial clock is input on SCL. START and STOP conditions are recognized as the beginning and end of a serial transfer.

## SLAVE ADDRESS

A control byte is the first byte received following the START condition from the master device. The control byte consists of a four bit control code; for the DS1676, this is set as 1101 binary for read and write operations. The next three bits of the control byte are the device select bits (A2, A1, A0). These bits are set to 011 (A2=0, A1=1, A0=1) for the DS1676. They are used by the master device to select which of eight devices are to be accessed. The set bits are in effect the three least significant bits of the slave address. The last bit of the control byte (R/W\*) defines the operation to be performed. When set to a one a read operation is selected, and when set to a zero a write operation is selected. Following the START condition, the DS1676 monitors the SDA bus checking the device type identifier being transmitted. Upon receiving the 1101 code and appropriate device select bits of 011, the DS1676 outputs an acknowledge signal on the SDA line.

**ABSOLUTE MAXIMUM RATINGS\***

Voltage on Any Pin Relative to Ground	-0.3V to +6V
Operating Temperature	-40°C to +85°C
Storage Temperature	-55°C to +125°C
Soldering Temperature	260°C for 10 seconds

- This is a stress rating only and functional operation of the device at these or any other conditions above those indicated in the operation sections of this specification is not implied. Exposure to absolute maximum rating conditions for extended periods of time may affect reliability.
- The Dallas Semiconductor DS1676X is built to the highest quality standards and manufactured for long term reliability. All Dallas Semiconductor devices are made using the same quality materials and manufacturing methods. However, the DS1676X is not exposed to environmental stresses, such as burn-in, that some industrial applications require. For specific reliability information on this product, please contact the factory in Dallas at (972) 371-4448.

**RECOMMENDED DC OPERATING CONDITIONS** (-40°C to 85°C)

PARAMETER	SYMBOL	MIN	TYP	MAX	UNITS	NOTES
Power Supply Voltage	V <sub>CC</sub>	2.5		5.5	V	1
Input Logic 1	V <sub>IH</sub>	2.2		V <sub>CC</sub> +0.3	V	1
Input Logic 0	V <sub>IL</sub>	-0.3		+0.8	V	1

**DC ELECTRICAL CHARACTERISTICS** (-40°C to 85°C; V<sub>CC</sub> = 2.5 to 5.5V)

PARAMETER	SYMBOL	MIN	TYP	MAX	UNITS	NOTES
Input Leakage	I <sub>LI</sub>	-1		+1	μA	
Logic 1 Output	V <sub>OH</sub>	2.4			V	
Logic 0 Output	V <sub>OL</sub>			0.4	V	
SDA & SCL Pins Output Current @0.8V	I <sub>OL</sub>	4			mA	
Active Supply Current	I <sub>CCA</sub>		300	500	μA	
Event Trip Point	V <sub>ETP</sub>		0.5*V <sub>CC</sub>		V	

**AC ELECTRICAL CHARACTERISTICS** (-40°C to 85°C; V<sub>CC</sub> = 2.5 to 5.5V)

PARAMETER	SYMBOL	MIN	TYP	MAX	UNITS	NOTES
EEPROM Lockout Time after event	t <sub>EEV</sub>	500			ms	
Time from Event = (0.5*V <sub>CC</sub> ) until ETC Fully Stored (V <sub>CC</sub> > 2.7V)	t <sub>PF</sub>	50		100	ms	
EEPROM Write Time	t <sub>EW</sub>		5		ms/byte	
Minimum Signal Hold Time	t <sub>SIG</sub>	TBD			mS	
Minimum Event Hold	t <sub>EVNT</sub>	TBD			mS	
Input Capacitance	C <sub>i</sub>		5		pF	



**AC ELECTRICAL CHARACTERISTICS**(-40°C to 85°C;  $V_{CC} = 2.5$  to 5.5V)

PARAMETER	SYMBOL	MIN	TYP	MAX	UNITS	NOTES
SCL clock frequency	fsc1			100	kHz	
Bus free time between a STOP and START condition	tbuf	4.7			$\mu$ s	
Hold time (repeated) START condition.	thd:sta	4.0			$\mu$ s	2
LOW period of SCL	tlow	4.7			$\mu$ s	
HIGH period of SCL	thigh	4.0			$\mu$ s	
Set-up time for a repeated START	tsu:sta	4.7			$\mu$ s	
Data hold time	thd:dat	0			$\mu$ s	
Data set-up time	tsu:dat	250			ns	
Rise time of both SDA and SCL signals	tr			1000	ns	
Fall time of both SDA and SCL signals	tf			1000	ns	
Set-up time for STOP	tsu:sto	4.0			$\mu$ s	
Capacitive load for each bus line	Cb			400	pF	3
Input Capacitance	Ci		5		pF	

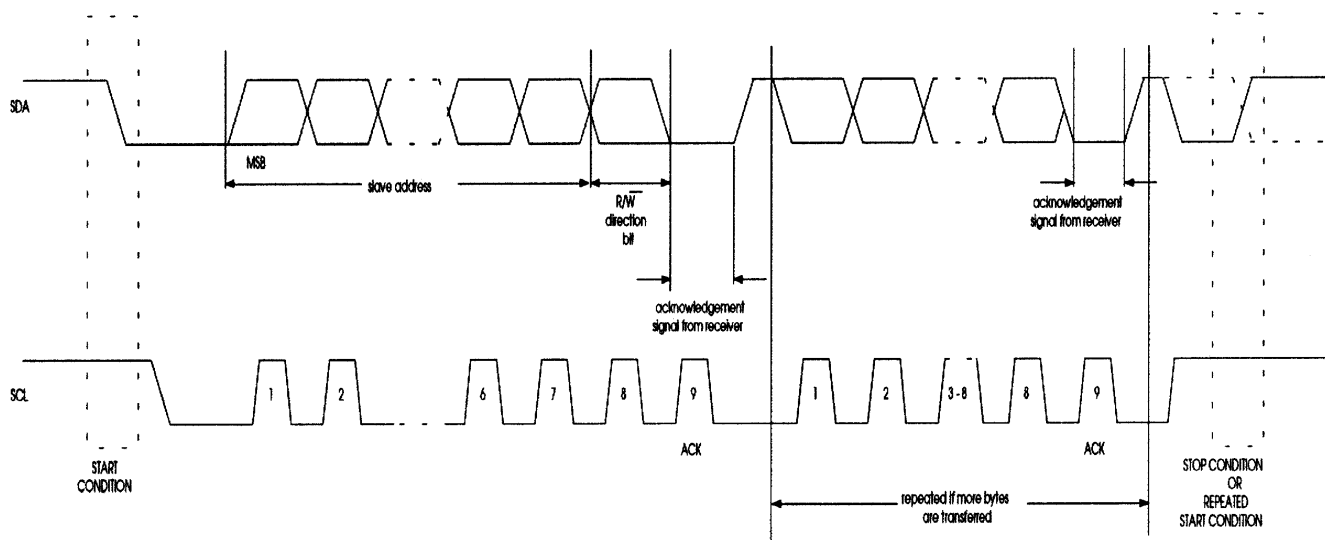
**TIMING DIAGRAM: DATA TRANSFER ON 2-WIRE SERIAL BUS Figure 2****NOTES:**

1. All voltages are referenced to ground,
2. After this period, the first clock pulse is generated.
3. Cb - total capacitance of one bus line in pF.

DS1675 in a Total Time of Use application with AC Power that may be removed at the same time as the end of the event.

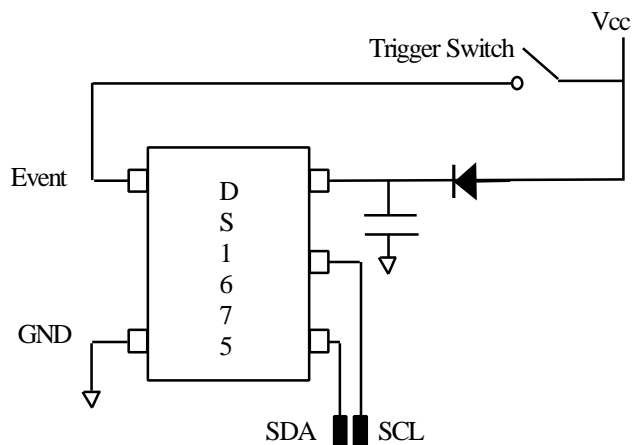

The DS1682 measuring total run time and operating off of a battery with the alarm tied to an LED and a push button switch to trigger the alarm output.

