



# IBM PC/XT/AT Compatible Modular Analog and Digital I/O Board

## RTI<sup>®</sup>-820

### FEATURES

- Analog and Digital I/O on One Board
- 12-Bit A/D and D/A Resolution
- High Channel Expansion Capacity
  - 64 Analog Inputs
  - 16 Analog Outputs
  - 24 Digital I/O
- Analog Input Acquisition Rates up to 19 kHz
- Analog Output Update Rates of 400 Hz on Each Channel
- Wide Range of Interface Panels Used for Direct Connection to Thermocouples and RTDs
- Choice of Isolated or Nonisolated I/O

### SOFTWARE

- Callable I/O Drivers for Use with Multiple High Level Languages
- Calibration Routines
- Menu-Driven Application Software Support

### APPLICATIONS

- Laboratory R and D
- Data Logging
- Product Test
- Process Control

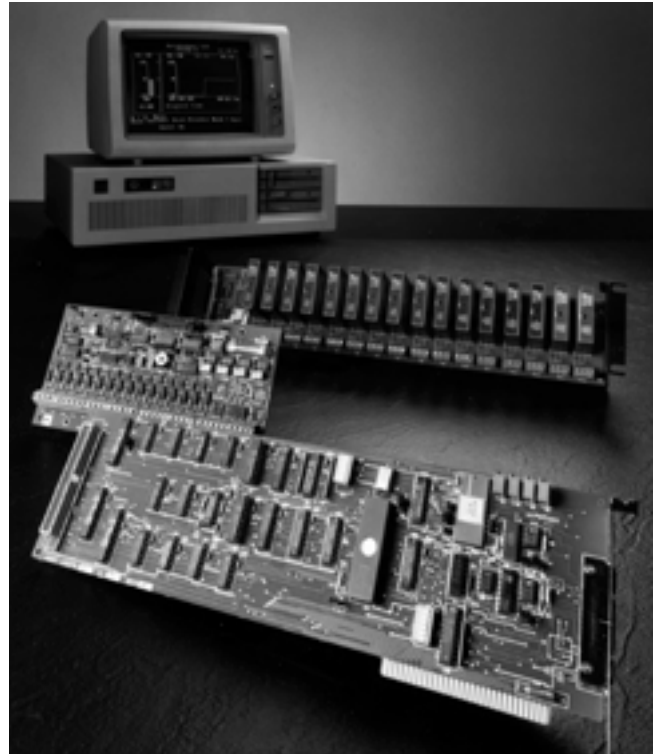

### GENERAL DESCRIPTION

The RTI-820 is a low cost analog and digital I/O board that plugs into one of the long expansion slots in the IBM PC/XT/AT\* or equivalent personal computer. Used with a wide variety of interface panels, the board accepts a variety of signals with up to 64 analog input channels, 16 analog output channels, and 24 channels of digital I/O accommodated in a single PC slot. The RTI-820 provides 12-bit A/D and D/A resolution, acquisition rates up to 19 kHz, and a wide variety of signal conditioning options for either isolated or nonisolated I/O.

Three analog I/O interface panels are available for use with the RTI-820. The high level voltage panel (STB-HL) provides screw terminations for 16 high level (V) single-ended analog inputs and 4 analog outputs and open positions for user installed attenuators, filters or current shunts. The thermocouple panel (STB-TC) provides screw terminations for 16 low level (mV) differential analog inputs or 15 thermocouples with cold junction compensation. Finally, the 5B interface panel (5B02) provides 16 galvanically isolated analog I/O channels using the 5B

Series signal conditioning modules. The 5B modules provide for direct connection to volts, millivolts, current input and output, thermocouples and RTDs at up to  $\pm 240$  V input protection and 1500 V rms isolation. If isolation is not required, the high level voltage and thermocouple panels provide an economical solution for signal termination. In addition, the 24 channels of digital I/O connect via a ribbon cable to either a nonisolated panel (AC1585-1) for TTL level I/O or to an isolated digital I/O subsystem (DB-24) for high level digital I/O.

The RTI-820 and its hardware accessories are supported by three levels of software: assembly language programming, high level language drivers, and menu-driven application software. Refer to the separate software data sheets for more detailed information.

The RTI-820 is a member of the RTI I/O Board Family.

RTI is a registered trademark of Analog Devices, Inc.

\*IBM PC/XT/AT is a trademark of International Business Machines Corp.

### REV. A

Information furnished by Analog Devices is believed to be accurate and reliable. However, no responsibility is assumed by Analog Devices for its use, nor for any infringements of patents or other rights of third parties which may result from its use. No license is granted by implication or otherwise under any patent or patent rights of Analog Devices.

One Technology Way, P.O. Box 9106, Norwood, MA 02062-9106, U.S.A.  
Tel: 781/329-4700 World Wide Web Site: <http://www.analog.com>  
Fax: 781/326-8703 © Analog Devices, Inc., 1998

# RTI-820

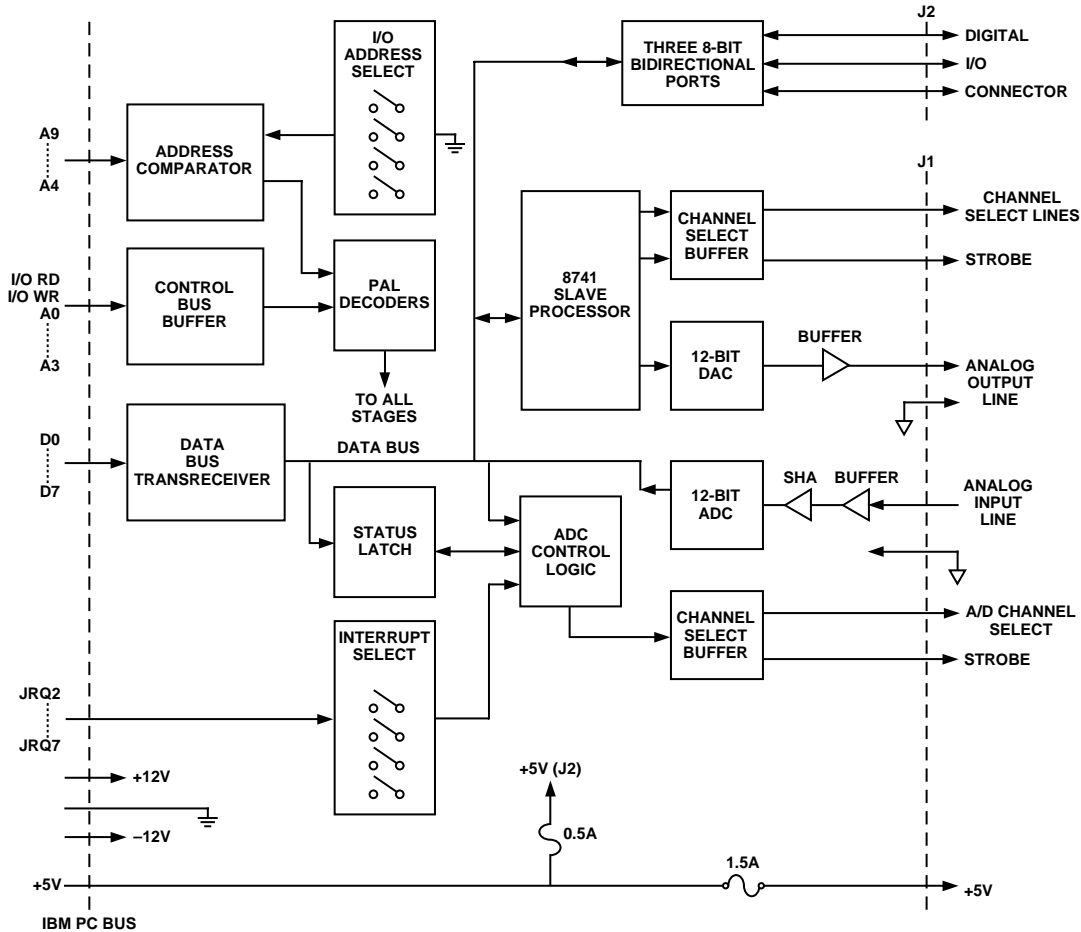

Figure 1. Block Diagram

## ANALOG I/O

The RTI-820 contains one 12-bit A/D converter and one 12-bit D/A converter that provide one channel of analog input and one channel of analog output, respectively. Multiple channels are accommodated with the interface panels by multiplexing several input and output channels into the single I/O lines of the RTI-820 through the J1 connector. The multiplexing functions on the interface panels are controlled by the decoding lines on the analog I/O connector. Six analog input lines and four analog output lines are supplied to provide for a maximum of 64 analog inputs and 16 analog outputs into a single RTI-820 board.

A/D conversions can be initiated from a software convert command or triggered externally from a TTL level pulse to allow the conversion process to be synchronized with external events. The RTI-820 has the capability to generate an interrupt upon completion of an A/D conversion or when an overrun condition has occurred (i.e., an attempt has been made to initiate an A/D conversion before the necessary settling time).

Analog output, on the other hand, is implemented with a single D/A converter coupled with an onboard slave microprocessor.

The microprocessor's principle task is to periodically update all active output lines by storing the output data in RAM memory and controlling the D/A refresh rate. Individual sample and hold amplifiers (SHAs) will hold each output signal constant until the microprocessor updates the value, which occurs about once every two milliseconds. A timer inside the slave microprocessor will insure that each D/A channel is periodically refreshed. In this manner, one D/A converter is able to serve multiple analog output channels.

## DIGITAL I/O

The RTI-820 has three 8-bit digital I/O ports, each of which may be configured as either an input or output port. All digital I/O channels are inverse TTL level signals and are compatible with industry standard solid-state relay subsystems such as the Analog Devices DB-24 Isolated Digital I/O panel. The DB-24 panel uses up to six plug-in quad modules (four channels each) to provide optically isolated digital I/O. If isolation is not required, the AC1585-1 screw termination panel is available for direct connections to the RTI-820 board.

CONNECTING THE INTERFACE PANELS TO THE RTI-820

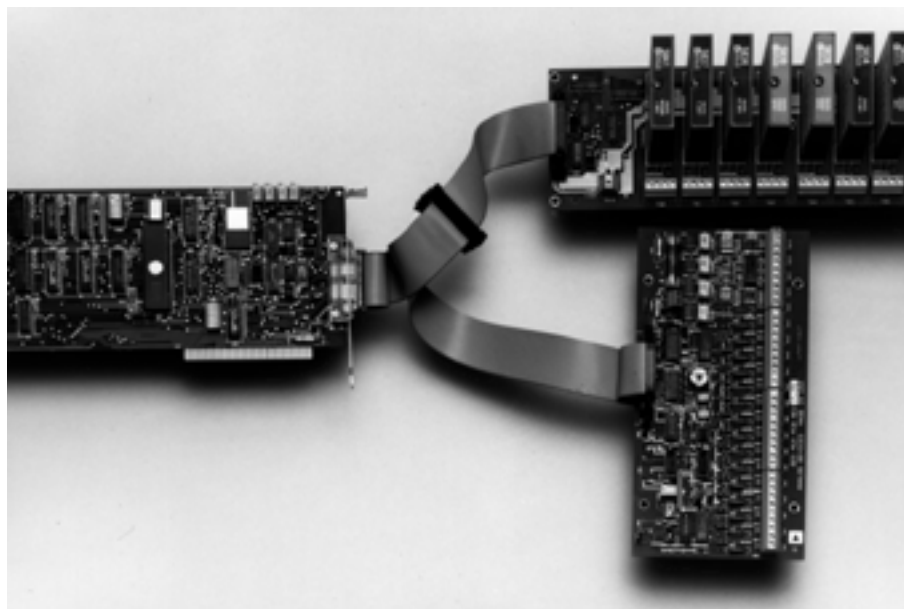

**Analog I/O**

The Analog I/O interface panels are connected to the RTI-820 through a 26-pin connector (J1). A 26-pin, 3 ft. ribbon cable connects the J1 connector to the 26-pin connector on the interface panel. If more than one panel is used, a second ribbon cable is daisy-chained off of the 26-pin connector of the cable, as shown in the above photo. Up to four interface panels, in any combination, can be connected in this manner.

**Digital I/O**

Digital I/O channels are also connected to the RTI-820 via external interface panels. The digital I/O interface panel is connected to the RTI-820 through a 50-pin connector (J2) and a 50-pin ribbon cable. The cable is connected to the J2 connector and runs through the retaining bracket and out to the digital interface panel.

**PANEL SELECTION GUIDE**

Several interface panels are available for use with the RTI-820. Analog I/O interface panels (rack mountable) are available for isolated or nonisolated high level voltages, low level voltages and specialized I/O such as thermocouples and RTDs. The multiple panel options not only provide the user with the opportunity of expanding the I/O configuration but also to condition the I/O as needed on a panel-by-panel basis. Similarly, there are two digital I/O panel options for either nonisolated TTL level I/O or isolated, high level sensing and switching.

Below is a list of the screw termination panels available for both the analog and digital I/O connections.

Table I. Termination Panels

Model #	Channel Capacity	Input Type	Output Types	Isolation	Power Required	Rack Mount Kit
<b>Analog I/O</b> STB-HL	16 AIN (SE)	High Level Voltage	High Level Voltage	No	+5 V @ 350 mA	RM-02
STB-TC	4 AOT 16 AIN (DI)	Thermocouples Low Level Voltage	None	No	+5 V @ 200 mA	RM-02
5B02	16 Analog I/O	Thermocouples RTDs Current Low Level Voltage High Level Voltage	Current (Voltage)	Yes ±1500 V rms	Dependent On Modules Used	AC1363
<b>Digital I/O</b> AC1581-1 DB-24	24 Digital I/O 24 Digital I/O	TTL Level High Level AC Voltage High Level DC Voltage	TTL Level High Level AC Voltage High Level DC Voltage	No Yes ±4000 V rms	None Dependent On Modules Used	None RM-02

**Table II. Panel and Module Selection Table**

Panel	Input Type	Input Range	Output Range	Model #	Resolution	Accuracy
<b>Analog Inputs</b>						
STB-HL	Volts	±5 V ±10 V	±5 V ±5 V		2.44 mV 4.88 mV	5.6 mV 11.2 mV
STB-TC	Millivolts/ Thermocouples (0 Hz–8 Hz)	±5 V ±0.1 V ±0.05 V ±0.025 V ±0.01 V ±0.005 V	±5 V ±5 V ±5 V ±5 V ±5 V ±5 V		2.44 mV 48.8 μV 24.4 μV 12.2 μV 4.88 μV 2.44 μV	5.6 mV 112 μV 59 μV 32 μV 19 μV 16 μV
5B02	Millivolts (0 Hz–4 Hz)	±0.01 V ±0.05 V ±0.10 V	±5 V ±5 V ±5 V	5B30-01 5B30-02 5B30-03	4.88 μV 24.4 μV 48.8 μV	11.2 μV 56 μV 112 μV
		±0.01 V ±0.05 V ±0.10 V	0–5 V 0–5 V 0 V	5B30-04 5B30-05 5B30-06	9.76 μV 48.8 μV 97.6 μV	22.4 μV 112 μV 224 μV
	Volts (0 Hz–4 Hz)	±1 V ±5 V ±10 V ±1 V	±5 V ±5 V ±5 V 0 V–5 V	5B31-01 5B31-02 5B31-03 5B31-04	0.488 mV 2.44 mV 4.88 mV 0.976 mV	1.12 mV 5.6 mV 11.2 mV 2.24 mV
		±5 V ±10 V	0 V–5 V 0 V–5 V	5B31-05 5B31-06	4.88 mV 9.76 mV	11.2 mV 22.4 mV
	Millivolts (0 Hz–10 kHz)	±0.01 V ±0.05 V ±0.01 V ±0.01 V ±0.05 V ±0.01 V	±5 V ±5 V ±5 V 0 V–5 V 0 V–5 V 0 V–5 V	5B40-01 5B40-02 5B40-03 5B40-04 5B40-05 5B40-06	4.88 μV 24.4 μV 48.8 μV 9.76 μV 48.8 μV 97.6 μV	11.2 μV 56 μV 112 μV 22.4 μV 112 μV 224 μV
	Volts (0 Hz–10 kHz)	±1 V ±5 V ±10 V ±1 V ±5 V ±10 V	±5 V ±5 V ±5 V 0 V–5 V 0 V–5 V 0 V–5 V	5B41-01 5B41-02 5B41-03 5B41-04 5B41-05 5B41-06	0.488 mV 2.44 mV 4.88 mV 0.976 mV 4.88 mV 9.76 mV	1.12 mV 5.6 mV 11.2 mV 2.24 mV 11.2 mV 22.4 mV
	Current (0 Hz–4 Hz)	4 mA–20 mA	0 V–5 V	5B32-01	7.81 μA	17.9 μA
	RTD (0 Hz–4 Hz)	0 mA–20 mA	0 V–5 V	5B32-02	9.76 μA	22.4 μA
	100 Ω Pt	–100°C to +100°C	0 V–5 V	5B34-01	0.097°C	0.22°C
		0°C to +100°C	0 V–5 V	5B34-02	0.048°C	0.12°C
		0°C to +200°C	0 V–5 V	5B34-03	0.097°C	0.22°C
		0°C to +600°C	0 V–5 V	5B34-04	0.29°C	0.67°C
	10 Ω Cu	0°C to +120°C (0°C)	0 V–5 V	5B34-C-01	0.058°C	0.13°C
		0°C to +120°C (25°C)	0 V–5 V	5B34-C-02	0.058°C	0.13°C
	120 Ω Ni	0°C to +300°C	0 V–5 V	5B34-N-01	0.146°C	0.34°C
Thermocouples	J	–100°C to +760°C	0 V–5 V	5B37-J-01	0.42°C	0.96°C
	K	–100°C to +1350°C	0 V–5 V	5B37-K-02	0.71°C	1.62°C
	T	–100°C to +400°C	0 V–5 V	5B37-T-03	0.24°C	0.56°C
	E	0°C to +900°C	0 V–5 V	5B37-E-04	0.44°C	1.01°C
	R	0°C to +1750°C	0 V–5 V	5B37-R-05	0.85°C	1.96°C
	S	0°C to +1750°C	0 V–5 V	5B37-S-05	0.85°C	1.96°C
	B	0°C to +1800°C	0 V–5 V	5B37-B-06	0.88°C	2.02°C
<b>Analog Outputs</b>						
STB-HL	Volts		0 V–5 V ±5 V		1.22 mV 2.44 mV	2.8 mV 5.6 mV
5B02	Current	0 V–5 V ±5 V 0 V–5 V ±5 V	4 mA–20 mA 4 mA–20 mA 4 mA–20 mA 0 mA–20 mA	5B39-01 5B39-02 5B39-03 5B39-04	3.91 μA 7.81 μA 4.88 μA 9.76 μA	8.96 μA 17.9 μA 11.2 μA 22.4 μA

Panel	Input Range	Output Range	Model #
<b>Digital Inputs</b>			
AC1585-1	TTL Level	TTL Level	
DB-24	4 V–16 V dc	TTL Level	ID16FQ
	10 V–32 V dc	TTL Level	ID32Q
	15 V–32 V ac	TTL Level	ID32Q
	90 V–140 V ac	TTL Level	IA120Q
	90 V–140 V dc	TTL Level	IA120Q
	180 V–280 V ac	TTL Level	IA240Q
	180 V–280 V dc	TTL Level	IA240Q
<b>Digital Outputs</b>			
AC1585-1	TTL Level	TTL Level	
DB-24	TTL Level	12 V–280 V ac	OA240Q
	TTL Level	5 V–60 V dc	OD60Q

# RTI-SPECIFICATIONS (typical @ +25°C and +5 V dc)

RTI-820

<b>ANALOG INPUT (RTI-820 BOARD ONLY)</b> Number of Analog Input Channels <sup>1</sup>  Input Resolution A/D Converter Time System Throughput <sup>2</sup> Accuracy	Up to 64 (Dependent on Interface Panel Used) Supports Up to Four Interface Panels in Any Combination 12 Bits (4096 Counts) 30 $\mu$ s typical 19 kHz maximum 0.025% ( $\pm 1$ LSB)
<b>ANALOG OUTPUT (RTI-820 BOARD ONLY)</b> Number of Analog Output Channels <sup>1</sup>  Output Resolution Update Rates Accuracy	Up to 16 (Dependent on Interface Panel Used) Supports Up to Four Interface Panels in Any Combination 12 Bits (4096 Counts) 400 Hz Each Channel 0.025% ( $\pm 1$ LSB)
<b>DIGITAL I/O (RTI-820 BOARD ONLY)</b> Number of Channels Signal Levels	24 (Software Selectable in Groups of Eight) Inverted TTL (Compatible to Solid-State Relay Subsystems) $V_{OL} = 0.4$ V maximum $I_{OL} = 23$ mA maximum
<b>SYSTEM CONFIGURATION</b> Bus Resource Utilization Data Acquisition Modes Base Address Selection Compatibility	Occupies One IBM PC Long Slot Polled Status or Interrupt DIP Switch Selectable, 16 Consecutive Bytes IBM PC/XT/AT and 100% Compatibles
<b>PHYSICAL/ENVIRONMENTAL</b> Operating Temperature Range Storage Temperature Range Relative Humidity	0°C to +70°C -25°C to +85°C Up to 90% (Noncondensing)
<b>POWER REQUIREMENTS (RTI-820 BOARD ONLY)</b> Power Consumption  +5 V Power Available on Analog I/O Connector +5 V Power Available on Digital I/O Connector	+5 V @ 650 mA +12 V @ 25 mA -12 V @ 40 mA Up to 1.5 Amps (Fused) Up to 0.5 Amps (Fused)

## NOTES

<sup>1</sup>The RTI-820 contains only one analog input line and one analog output line. The individual input and output channels are multiplexed at the interface panels. The RTI-820 itself is not able to measure multiple analog inputs and outputs but does provide the channel address and strobe lines for outboard accessory panels.

<sup>2</sup>System throughput includes A/D conversion time, multiplexing settling time (single channel only) and amplifier settling time, data transfer time, and minimal software overhead (assembly language). The system throughput represents the maximum rate measured in benchmark testing during development.

Specifications are subject to change without notice.

# INTERFACE PANEL SPECIFICATIONS (typical @ +25°C and +5 V dc)

<b>HL PANEL SPECIFICATIONS (MODEL STB-HL)</b> Number of Analog Input Channels Analog Input Voltage Range <sup>1</sup> Analog Input Accuracy Input Protection <sup>2</sup> Number of Analog Output Channels Analog Output Voltage Range Analog Output Accuracy Analog Output Noise Power Requirements Physical Dimensions Operating Temperature Range	16 Single-Ended $\pm 5$ V, $\pm 10$ V $\pm 0.05\%$ of Span $\pm 35$ V (Powered), $\pm 20$ V (Unpowered) 4 0 V-5 V, $\pm 5$ V @ 5 mA $\pm 0.05\%$ of Span 1 mV rms, 10 kHz Bandwidth +5 V @ 350 mA 8.25" $\times$ 6" $\times$ 1.41" 0°C to +60°C
---	---

# RTI-820

<p><b>TC PANEL SPECIFICATIONS</b></p> <p>Number of Analog Input Channels</p> <p>Input Voltage Range</p> <p>Input Overvoltage Protection</p> <p>Instrumentation Amplifier Gain Ranges</p> <p>Gain Accuracy<sup>3</sup></p> <p>Input Offset<sup>3</sup></p> <p>Output Offset<sup>3</sup></p> <p>CJC Accuracy</p> <p>Low-Pass Filter Frequency<sup>4</sup></p> <p>Common-Mode Rejection<sup>5</sup></p> <p>Power Requirements</p> <p>Physical Dimensions</p> <p>Operating Temperature Range</p>	<p>16 Differential (Accepts 15 Thermocouples Plus 1 Input of Cold Junction Compensation)</p> <p>±5 V</p> <p>±30 V</p> <p>1, 50, 100, 200, 500, 1000, User Defined</p> <p>±0.05%</p> <p>±15 µV</p> <p>±2.5 mV</p> <p>±1°C</p> <p>8 Hz</p> <p>100 dB</p> <p>+5 V @ 200 mA</p> <p>8.25" × 6" × 1.41"</p> <p>0°C to +60°C</p>
<p><b>5B PANEL SPECIFICATIONS (MODEL 5B02)</b></p> <p>For Detailed Specifications See The 5B Series Data Sheet</p> <p>Number of Analog I/O Channels</p> <p>Common-Mode Input Protection</p> <p>Common-Mode Rejection</p> <p>Normal-Mode Input Protection</p> <p>Physical Dimensions</p> <p>Operating Temperature Range</p>	<p>16 (Using Input or Output Plug-In Modules)</p> <p>+1500 V rms</p> <p>160 dB</p> <p>+240 V rms</p> <p>3.5" × 17.4" × 3" (with Modules Installed)</p> <p>-25°C to +85°C</p>
<p><b>DIGITAL I/O PANEL (MODEL DB-24)</b></p> <p>Number of Digital I/O Channels</p> <p>Isolation</p> <p>Power Requirements</p> <p>Physical Dimensions</p> <p>Operating Temperature Range</p>	<p>24 (Using Plug-In Isolator Quad Modules)</p> <p>+4000 V rms</p> <p>+5 V @ 50 mA per Quad Module</p> <p>8.0" × 6.0" × 3.9" (with Modules Installed)</p> <p>-30°C to +70°C</p>

**NOTES**

<sup>1</sup>The STB-HL has the capability to apply an offset to a ±5 V input signal to accommodate different input ranges (such as 0 V to 10 V).

<sup>2</sup>The STB-HL panel provides three sockets per input channel for user-installed resistor attenuators or low-pass filter circuits. Refer to the RTI-820 User's Manual for specific installation guidelines.

<sup>3</sup>Adjustable to zero.

<sup>4</sup>Removable.

<sup>5</sup>CMRR according to factory configuration of gain of 100 (at gain of 1, 80 dB; at gain 200 or greater, 110 dB).

Specifications are subject to change without notice.

**POWERING THE PANELS**

All of the RTI-820 analog I/O interface panels are powered by +5 volts. It may be necessary to power the panels from an external source, depending on the configuration used. The RTI-820 provides 1.5 amps of fused power on the +5 V pin of the analog I/O connector for powering up to two high level voltage or thermocouple panels. Configurations using three or more STB-HL or STB-TC panels must be powered externally. (External power is connected to each interface panel through onboard screw terminals). Note also that the 5B02 backplane must always be powered externally, since the +5 V power line is not available through the ribbon cable connector.

Similarly, the RTI-820 provides 0.5 amps of fused power on the +5 V pin of the digital I/O connector for powering the solid-state relay subsystem. The nonisolated AC1585-1 screw termination panel, however, does not require any external power.

**OEM SUPPORT**

The modular design of the RTI-820 is optimized for custom designing of application specific interface panels. All of the control logic and I/O lines are present at the analog I/O connector to allow OEMs to custom design lower cost and/or specialized signal conditioning panels. The technical information necessary to design custom interface panels is provided in the RTI-820 User's Manual.

C1063b-0-6/98

PRINTED IN U.S.A.