



Advanced Video Decoder with 10-Bit ADC, 3-Line Adaptive Comb Filter & Scaler

Preliminary Technical Data

ADV7185

FEATURES

- Analog Video to Digital YUV Video Decoder
 - NTSC-(M/N), PAL-(B/D/G/H/I/M/N)
- Integrates Two 10-Bit Accurate ADCs
- Clocked from a Single 27 MHz Crystal
- Dual Video Clocking Schemes
 - Line Locked Clock Compatible (LLC)
 - Fixed Frequency Oversampling 10-Bit Operation
- Adaptive-Digital-Line-Length-Tracking (ADLLT™)
- Real Time Clock & Status Information Output
- Integrated AGC (Automatic Gain Control) & Clamping
- Simplified Digital Interface
- On-Board Digital FIFO
- Optimised Programmable Video Source Modes
 - Broadcast TV
 - VCR/Camcorder
 - Security/Surveillance
- Multiple, Programmable Analog Input Formats:
 - CVBS (Composite Video)
 - YUV and SVHS (Y/C) (Component Video)
- 6 Analog Input Video Channels
- Real Time Horizontal and Vertical Scaling
- Adaptive 3-Line Luma and Chroma Comb Filter
- Automatic NTSC/PAL Identification
- Differential Mode Video Input
- VMI & VIP compliant video pixel port

Digital Output Formats (20-Bit Wide Bus):

- YCrCb (4:2:2 or 4:1:1)
- CCIR601/CCIR656 8-Bit or Extended 10-Bit
- 0.5V to 2.0V pk-pk i/p range
- Differential Gain < 1%
- Differential Phase < 1°
- Programmable Video Controls
 - Pk-White/Hue/Brightness/Saturation/Contrast
- CCIR/Square Pixel Operation
- Integrated On-Chip Video Timing Generator
- Synchronous or Asynchronous Output Timing
- Line Locked Clock Output
- Close Captioning Passthrough Operation
- Vertical Blanking Interval Support
- Power Down Mode
- 2-Wire Serial MPU Interface (I²C Compatible)
- +5V/+3V CMOS Supply Operation
- 80-Pin LQFP Package

APPLICATIONS

- Video Conferencing
- Hybrid Analog/Digital Set Top Boxes
- PC Video/Multimedia
- Professional Studio Quality Video
- Camcorders
- Security Systems/Surveillance

GENERAL DESCRIPTION

The ADV7185 is an integrated video decoder that automatically recognises and converts a standard analog baseband television signal compatible with world wide standards NTSC or PAL into 4:2:2 or 4:1:1 component video data compatible with 16-bit/8-Bit CCIR601/CCIR656 8-Bit or 10-bit extended standards.

The advanced and highly flexible digital output interface enables performance video decoding and conversion in both frame-buffer based and line locked clock based systems. This makes the device ideally suited for a broad range of applications with diverse analog video characteristics including tape based sources, broadcast sources, security/surveillance cameras and professional systems.

Fully integrated line stores enable 3-line comb filtering in both luminance and chrominance data paths, plus real time horizontal and vertical scaling of captured video down to icon size. The 10-bit accurate A/D conversion provides professional quality SNR performance. This allows true 8-bit resolution in the 8-bit output mode and broadcast quality in 10-bit extended mode.

The 6 analog inputs channel accept standard composite or

advanced component video including S-Video and YUV video signals in an extensive number of combinations. AGC and Clamp Restore circuitry allow an input video signal peak to peak range of 0.5V up to 2V. Alternatively these can be bypassed for manual settings.

The fixed 27 MHz clocking of the ADCs and datapath for all modes allows very precise and accurate sampling and digital filtering. The Line Locked Clock output allows the output data rate, timing signals and output clock signals to be synchronous, asynchronous or line locked even with +/-5% line length variation. The output control signals allow glueless interface connection in almost any application.

The ADV7185 modes are set up over a two wire serial bidirectional port (I²C compatible).

The ADV7185 is fabricated in a +5V CMOS process. Its monolithic CMOS construction ensures greater functionality with lower power dissipation.

The ADV7185 is packaged in a small 80 pin LQFP package.

Rev. PrA 05/99

Information furnished by Analog Devices is believed to be accurate and reliable. However, no responsibility is assumed by Analog Devices for its use, nor for any infringements of patents or other rights of third parties which may result from its use. No license is granted by implication or otherwise under any patent or patent rights of Analog Devices.

* ADV is a Registered Trademark of Analog Devices, Inc.

One Technology Way, P.O. Box 9106, Norwood, MA 02062-9106, U.S.A.
Tel: 617/329-4700 World Wide Web Site: <http://www.analog.com>
Fax: 617/326-8703 © Analog Devices, Inc., 1997

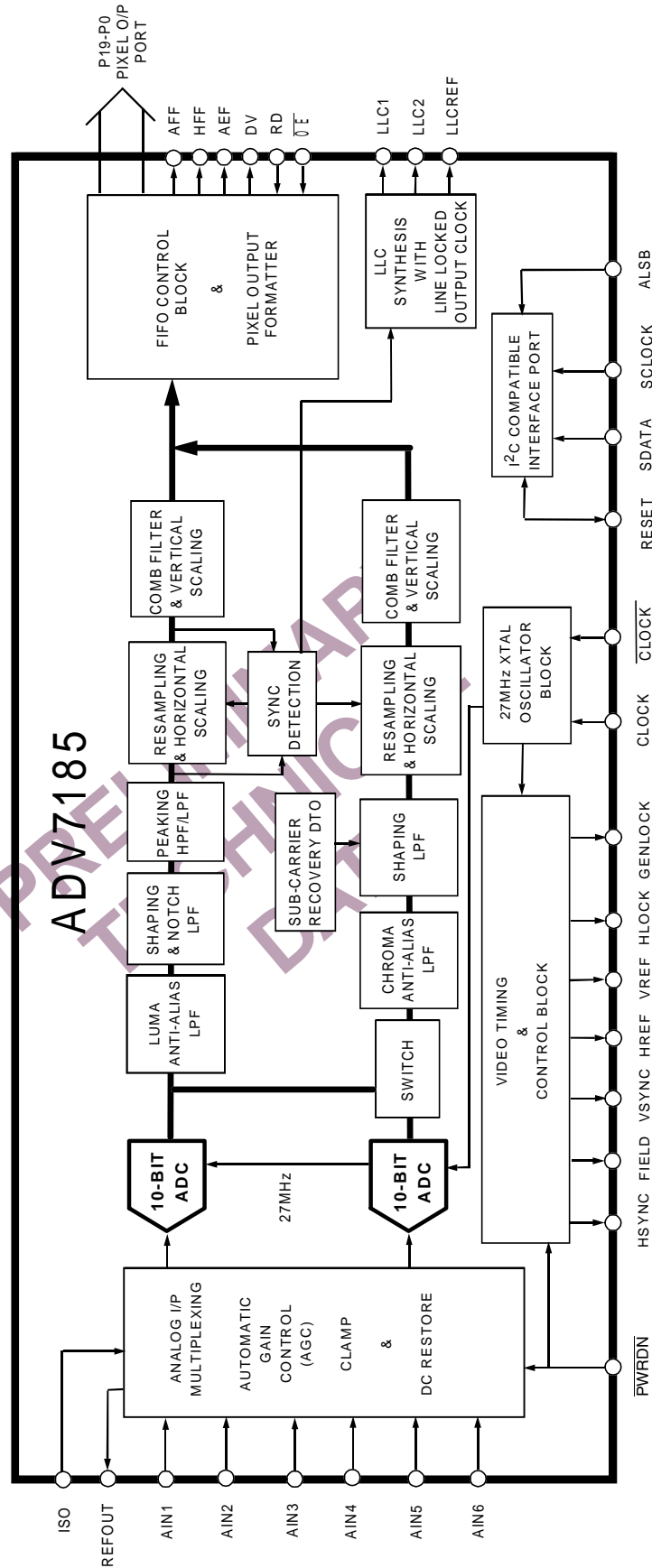

FUNCTIONAL BLOCK DIAGRAM

PIN DESCRIPTION

Mnemonic	Input/Output	Function
P19-P0	O	Video pixel output port. 8-Bit Multiplexed YCrCb Pixel Port (P9-P2), 16-Bit YCrCb Pixel Port (P19-P12=Y & P9-P2=Cb,Cr), 10-Bit Multiplexed Extended YCbCr Pixel Port (P9-P0) and 20-Bit YCbCr Pixel Port (P19-P0), P0 represents the LSB. P1-P0 can also be configured as GP0[1] and GPO[0] and P11-P10 can be configured as GP0[3] and GPO[2] respectively.
XTAL	I	Input terminal for 27MHz crystal oscillator or connection for external oscillator with CMOS compatible square wave clock signal
XTAL1	O	Second terminal for crystal oscillator; not connected if external clock source is used
DVSS1-3	G	Ground for Digital supply
DVDD1-3	P	Digital Supply Voltage (+5V)
DVDDIO	P	Digital I/O supply Voltage (+5V/+3.3V)
DVSSIO	G	Digital I/O ground
AVSS	G	Ground for Analog Supply
AVDD	P	Analog Supply Voltage (+5V)
AVSS1-6	G	Analog Input Channels ground
AIN1-6	I	Video Analog Input Channels
SCLOCK	I	MPU Port Serial Interface Clock Input.
SDATA	I/O	MPU Port Serial Data Input/Output.
ALSB	I	TTL Address Input, it selects the MPU address; MPU address = 88H ALSB = 0 MPU address = 8AH ALSB = 1
RD	I	Asynchronous FIFO Read Enable signal. A logical high on this pin enables a read from the output of the FIFO.
DV	O	DV or Data Valid output signal. In SCAPI/CAPI mode: DV performs a two functions depending on whether SCAPI or CAPI is selected. It toggles high when the FIFO has reached the AFF margin set by the user, and remains high until the FIFO is empty. The alternative mode is where it can be used to control FIFO reads for bursting information out of the FIFO. In API mode DV indicates valid data in the FIFO, which includes both pixel information and control codes. The polarity of this pin is controlled via PDV.
$\overline{\text{OE}}$	I	Output Enable controls pixel port outputs. A logical low will tri-state P19-P0.
$\overline{\text{HREF}}/\overline{\text{HRESET}}$	O	Dual function pin, HREF or Horizontal Reference output signal (enabled when Line Locked Interface is selected, OM_SEL[1:0] = 0,0); this signal is used to indicate data on the YUV output. The positive slope indicates the beginning of a new active line, HREF is always 720 Y samples long. $\overline{\text{HRESET}}$ or Horizontal Reset Output (enabled when SCAPI or CAPI is selected, OM_SEL[1:0] = 0,1 or 1,0) is a signal that indicates the beginning of a new line of video. In SCAPI/CAPI this signal is one clock cycle wide and is output relative to CLKIN. It immediately follows the last active pixel of a line. The polarity of this pin is controlled via PHVR.

PIN DESCRIPTION

Mnemonic	Input/Output	Function
$\overline{\text{VREF}}/\overline{\text{VRESET}}$	O	VREF or Vertical Reference output signal, indicates start of next field). $\overline{\text{VRESET}}$ or Vertical Reset Output is a signal that indicates the beginning of a new field. In SCAPI/CAPI mode this signal is one clock wide and active low relative to CLKIN. It immediately follows $\overline{\text{HRESET}}$ pixel, and it indicates that the next active pixel is the first active pixel of the next field.
LLCREF	O	Clock reference output; this is a clock qualifier distributed by the internal CGC for a data rate of LLC2. The polarity of LLCREF is controlled by PLLCREF bit.
LLC1/PCLK	O	Dual function pin, Line Locked Clock system output clock (27MHz \pm 5%) or a FIFO output clock ranging from 20-35MHZ.
LLC2	O	Line locked clock system output clock/2 (13.5MHz).
HLOCK	O	Horizontal locked: output signal indicating horizontal locking status, a logical high indicates the ADV7185 is locked horizontally to the input video source.
$\overline{\text{RESET}}$	I/O	System Reset, can be configured as an Input or Output signal (the RES bit can be used to control this pin).
$\overline{\text{PWRDN}}$	I	Power Down enable, a logical low will place part in a power down status.
REFOUT	O	Internal Voltage Reference Output.
CML	O	Common Mode Level for ADC.
AEF	O	Almost Empty Flag is a FIFO control signal. It indicates when the FIFO has reached the almost empty margin set by the user (use FFM[4:0]). The ploarity of this signal is controlled by PFF bit.
HFF/QCLK/GL	I/O	Multi function pin, Half Full Flag (OM_SEL[1:0] = 1,0) is a FIFO control signal which indicates when the FIFO is half full. The QCLK (OM_SEL[1:0] = 0,1) pin function is a qualified pixel output clock when using FIFO SCAPI mode. The GL (OM_SEL[1:0] = 0,0) function (Genlock output) is a signal that contains a serial stream of data which contains information for locking the subcarrier frequency. The ploarity of HFF signal is controlled by PFF bit.
AFF	O	Almost Full Flag is a FIFO control signal. It indicates when the FIFO has reached the almost full margin set by the user (use FFM[4:0]). The ploarity of this signal is controlled by PFF bit.
CLKIN	I	FIFO is an asynchronous FIFO clock. This asynchronous clock is used to output data onto the P19-P0 bus and other control signals. The LLC1 clock can be tied to this pin and the frequency programmed by CLKVAL[13:0].
FIELD	O	ODD/EVEN field output signal. A active state indicates that an even field is being digitized. The polarity of this signal is controlled by PF bit.
HS/HACTIVE	O	Dual function pin, HS or Horizontal Sync (OM_SEL[1:0] = 0,0) is a programmable horizontal sync output signal. The rising and falling edges can be controlled by HSB[9:0] and HSE[9:0] in steps of 2 LLC1. The ploarity of HS signal is controlled by PHS bit. HACTIVE (OM_SEL[1:0] = 1,0 or 0,1) is an output signal that is active during the active/viewable period of a video line. The active portion of a video line is programmable on the ADV7185. The ploarity of HACTIVE is controlled by PHS bit.
VS/VACTIVE	O	Dual function pin, VS or Vertical Sync (OM_SEL[1:0] = 0,0) is an output signal that indicates a vertical sync with respect to the YUV pixel data. The active period of this signal is six lines of video long. The ploarity of VS signal is controlled by PVS bit. VACTIVE (OM_SEL[1:0] = 1,0 or 0,1) is an output signal that is active during the active/viewable period of a video field. The ploarity of VACTIVE is controlled by PVS bit.

PIN DESCRIPTION

Mnemonic	Input/Output	Function
ISO	I	ISO or Input Switch Over is an input that indicates to the decoder core that the input video source has been changed externally and configures the decoder to reacquire the new timing information of the new source. This is useful in applications where external video muxs are used. This input gives the advantage of faster locking to the external muxed video sources.
CAPY1-2	I	ADC Capacitor network
CAPC1-2	I	ADC Capacitor network

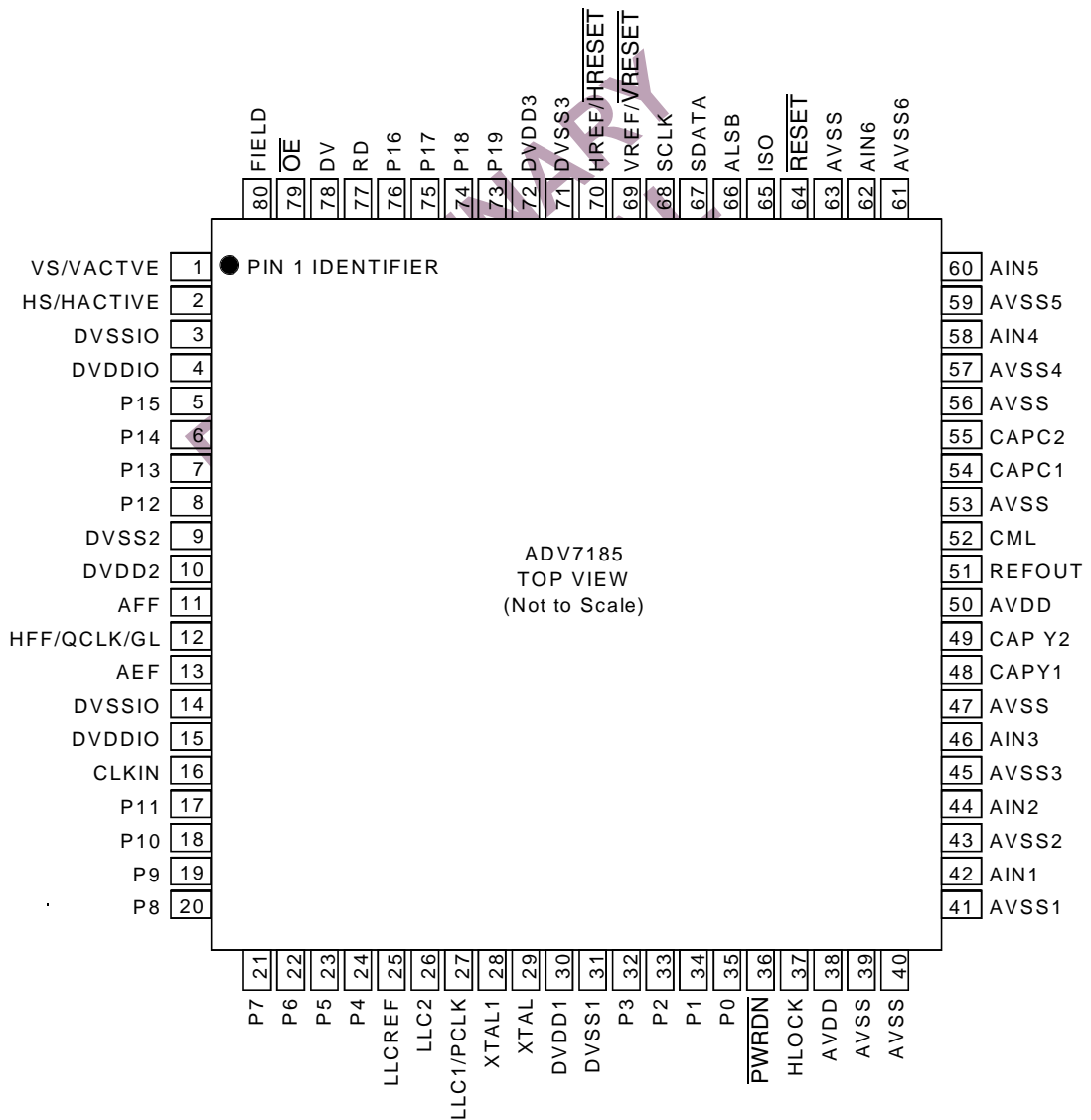

ADV7185 PIN FUNCTIONALITY

**PRELIMINARY
TECHNICAL
DATA**

5V SPECIFICATIONS¹ ($V_{AA} = +5V \pm 5\%$, $V_{DD} = +5V \pm 5\%$,
All specifications T_{MIN} to T_{MAX} ² unless otherwise noted)

Parameter	Min	Typ	Max	Units	Test Conditions
STATIC PERFORMANCE					
Resolution (each ADC)			10	Bits	
Accuracy (each ADC)					
Integral Nonlinearity		±1.0		LSB	
Differential Nonlinearity		±0.5		LSB	
DIGITAL INPUTS					
Input High Voltage, V_{INH}	2			V	
Input Low Voltage, V_{INL}			0.8	V	
Input Current, I_{IN}	-1.0		1.0	µA	
Input Capacitance, C_{IN}			10	pF	
DIGITAL OUTPUTS					
Output High Voltage, V_{OH}	2.4			V	$I_{SINK} = 0.4\text{ mA}$ $I_{SOURCE} = 3.2\text{ mA}$
Output Low Voltage, V_{OL}			0.4	V	
High Impedance Leakage Current			10	µA	
Output Capacitance			30	pF	
POWER REQUIREMENTS					
Digital Power Supply, V_{DD}	4.75	5.0	5.25	V	YUV , square pixel, $V_{DD}=5.25V$ YUV , square pixel, $V_{AA}= 5.25V$ Sleep mode until powered up
Analog Power Supply, V_{AA}	4.75	5.0	5.25	V	
Digital Supply Current, I_{DD}			110	mA	
Analog Supply Current, I_{AA}			75	mA	
Power-up Time		1		field	
AGC LOOP					
Time Constant		tbd		lines	TV mode: Sync depth variation until settled
Time Constant		tbd		lines	Surveillance mode: White peak violation until settled

NOTE

¹ The max/min specifications are guaranteed over this range. The max/min values are typical over 4.75 V to 5.25 V range

² Temperature Range T_{MIN} to T_{MAX} : 0°C to 70°C.

Specifications subject to change without notice.

5V VIDEO PERFORMANCE SPECIFICATIONS¹ ($V_{AA} = +5V \pm 5\%$, $V_{DD} = +5V \pm 5\%$, All specifications T_{MIN} to T_{MAX} ² unless otherwise noted)

Parameter	Min	Typ	Max	Units	Test Conditions
NON-LINEAR SPECIFICATIONS					
Differential Phase		1		deg	CVBS, Comb/No Comb
Differential Gain		1		%	CVBS, Comb/No Comb
Luma Non-Linearity		1		%	
Chroma Non-Linear Gain		1		%	
NOISE SPECIFICATIONS					
SNR (Pedestal)		70		dB	CVBS
SNR (Ramp)		62		dB	CVBS
Analog Front End Channel Crosstalk		tbd		dB	S-Video/ YUV, single ended
Analog Front End Channel Crosstalk		tbd		dB	S-Video/ YUV, differential ended
LOCK TIME AND JITTER SPECIFICATIONS					
Horizontal Lock Time		20	tbd	lines	TV / VCR mode
Horizontal Recovery Time		20	tbd	lines	
Horizontal Lock Range		± 5		%	
Line Length Variation Over Field		± 5		%	VCR mode/ Surveillance mode
Line Length Variation Over Field		± 1		%	TV mode
HLock Lost Declared		10	tbd	HSync	TV mode, No. of missing HSyncs
HLock Lost Declared		30	tbd	HSync	VCR/Surveillance mode, No. of missing HSyncs
Vertical Lock Time		2	tbd	VSync	First Lock into video signal
VLock Lost Declared		1	tbd	VSync	All modes, No. of missing VSynCs
F _{SC} Subcarrier Lock Range		± 400		Hz	NTSC/PAL
Color Lock Time			15	lines	HLock to Color Lock Time
Data Jitter Resampling		1		ns	
LLC Jitter		0.5	tbd	ns	tbd
CHROMA SPECIFIC SPECIFICATIONS					
Hue Accuracy		1		deg	
Color Saturation Accuracy		1		%	
Color Gain Control Range		-6	18	dB	S-Video, YUV, Overall CGC Range(analog and digital)
Analog Color Gain Range		-6	6	dB	S-Video, YUV
Digital Color Gain Range		0	12	dB	CVBS, S-Video, YUV
LUMA SPECIFIC SPECIFICATIONS					
Luma Brightness Accuracy		tbd		%	Video Input Range = 1.0Vp-p
Luma Contrast Accuracy		tbd		%	Video Input Range = 1.0Vp-p

NOTE

¹ The max/min specifications are guaranteed over this range. The max/min values are typical over 4.75 V to 5.25 V range

² Temperature Range T_{MIN} to T_{MAX} : 0°C to 70°C.

Specifications subject to change without notice.

5V TIMING SPECIFICATIONS¹

($V_{AA} = +5V \pm 5\%$, $V_{DD} = +5V \pm 5\%$,
All specifications T_{MIN} to T_{MAX} ² unless otherwise noted)

Parameter	Min	Typ	Max	Units	Test Conditions
SYSTEM CLOCK AND CRYSTAL Nominal Frequency		27		MHz	
I ² C PORT					
SCL Clock Frequency	0		400	kHz	
SCL min pulse width high, t_1	0.6			μ s	
SCL min pulse width low, t_2	1.3			μ s	
Hold Time (Start Condition), t_3	0.6			μ s	
Setup time (Start Condition), t_4	0.6			μ s	
Data Setup Time, t_5	100			ns	
SCL/SDA Rise Time, t_6			300	ns	
SCL/SDA Fall Time, t_7			300	ns	
Setup Time (Stop Condition), t_8		0.6		μ s	
RESET FEATURE					
Reset Pulse Input Width	tbd			μ s	
Reset Pulse Output Width	tbd			μ s	
CLOCK OUTPUTS					
LLC Cycle Time	33.8	37	40.7	ns	CCIR601 video, nominal line length and square pixel lengths CCIR 601 video, nominal line length and square pixel lengths
LLC2 Cycle Time	67.6	74	81.4	ns	
LLC to LLC2 Delay		1		ns	
LLC to Data Delay		tbd		ns	
LLC duty cycle	40	50	60	%	
LLC/LLC2 rise time			5	ns	
LLC/LLC2 fall time			5	ns	
DATA AND CONTROL OUTPUT					
Data Output Hold Time		tbd		ns	
Data Setup Time		tbd		ns	
Propagation Delay to HiZ		tbd		ns	

NOTE

¹ The max/min specifications are guaranteed over this range. The max/min values are typical over 4.75 V to 5.25 V range

² Temperature Range T_{MIN} to T_{MAX} : 0°C to 70°C.

Specifications subject to change without notice.

5V ANALOG FRONT END SPECIFICATIONS¹

($V_{AA} = +5V \pm 5\%$, $V_{DD} = +5V \pm 5\%$,
All specifications T_{MIN} to T_{MAX} ² unless otherwise noted)

Parameter	Min	Typ	Max	Units	Test Conditions
PROGRAMMABLE GAIN AMPLIFIER					
Temperature Stability		0.2	tbd	%	Over temperature range
Supply Stability		0.2	tbd	%	Over V_{AA} range
Absolute Gain Variation		2	tbd	%	Dependent on process
Resolution		9	tbd	bits	Linear in dB
Gain Range Luma	-6		6	dB	
Gain Range Chroma	-6		6	dB	
Input Voltage Range	0.5	1.0	2.0	V	
CLAMP CIRCUITRY					
External Clamp Capacitor		0.1		μF	Clamp switched off Signal already clamped (fine clamping)
Input Impedance		200		$k\Omega$	
Clamp Source Current		2		μA	
Clamp Sink Current		2		μA	Signal already clamped (fine clamping)
Clamp Source Current		tbd		mA	Acquire mode (fast clamping)
Clamp Sink Current		tbd		mA	Acquire mode (fast clamping)

NOTE

¹ The max/min specifications are guaranteed over this range. The max/min values are typical over 4.75 V to 5.25 V range

² Temperature Range T_{MIN} to T_{MAX} : 0°C to 70°C.

Specifications subject to change without notice.

PRELIMINARY
TECHNICAL
DATA

PRELIMINARY
TECHNICAL
DATA

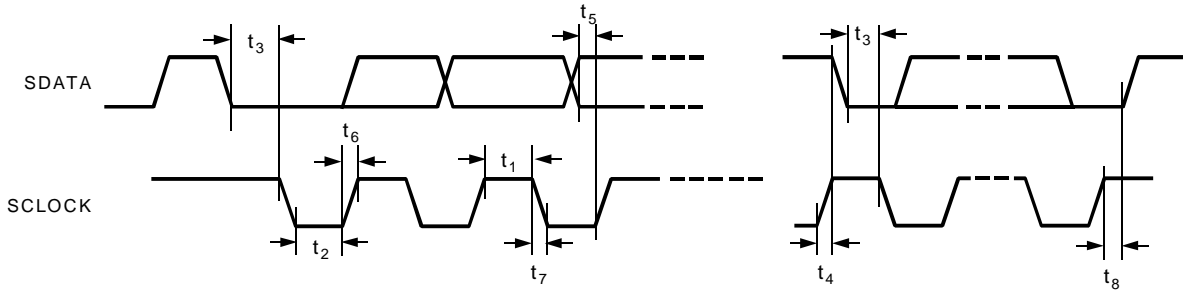

Figure 2. MPU Port Timing Diagram

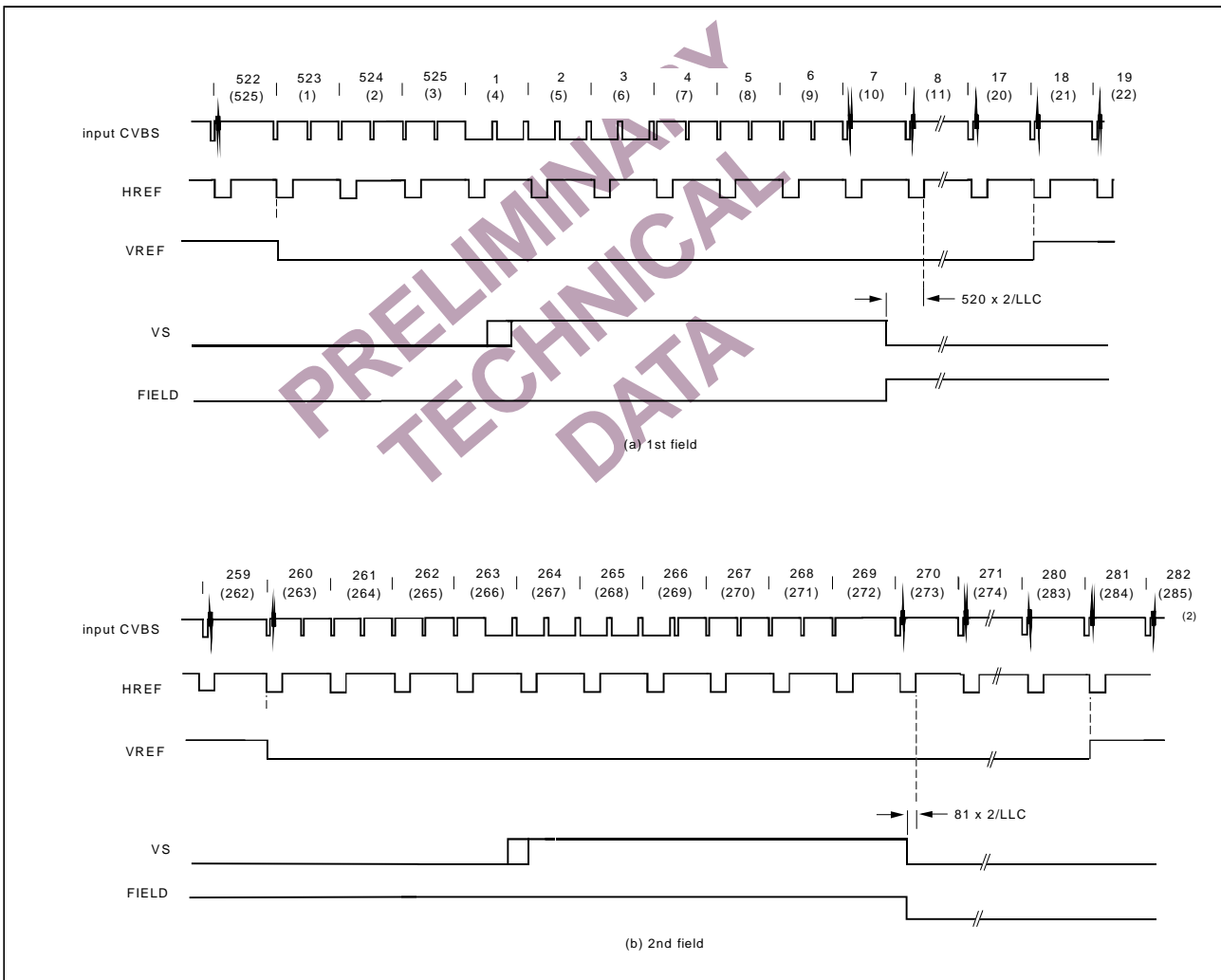

Figure 3. Vertical Timing Diagram 50Hz system

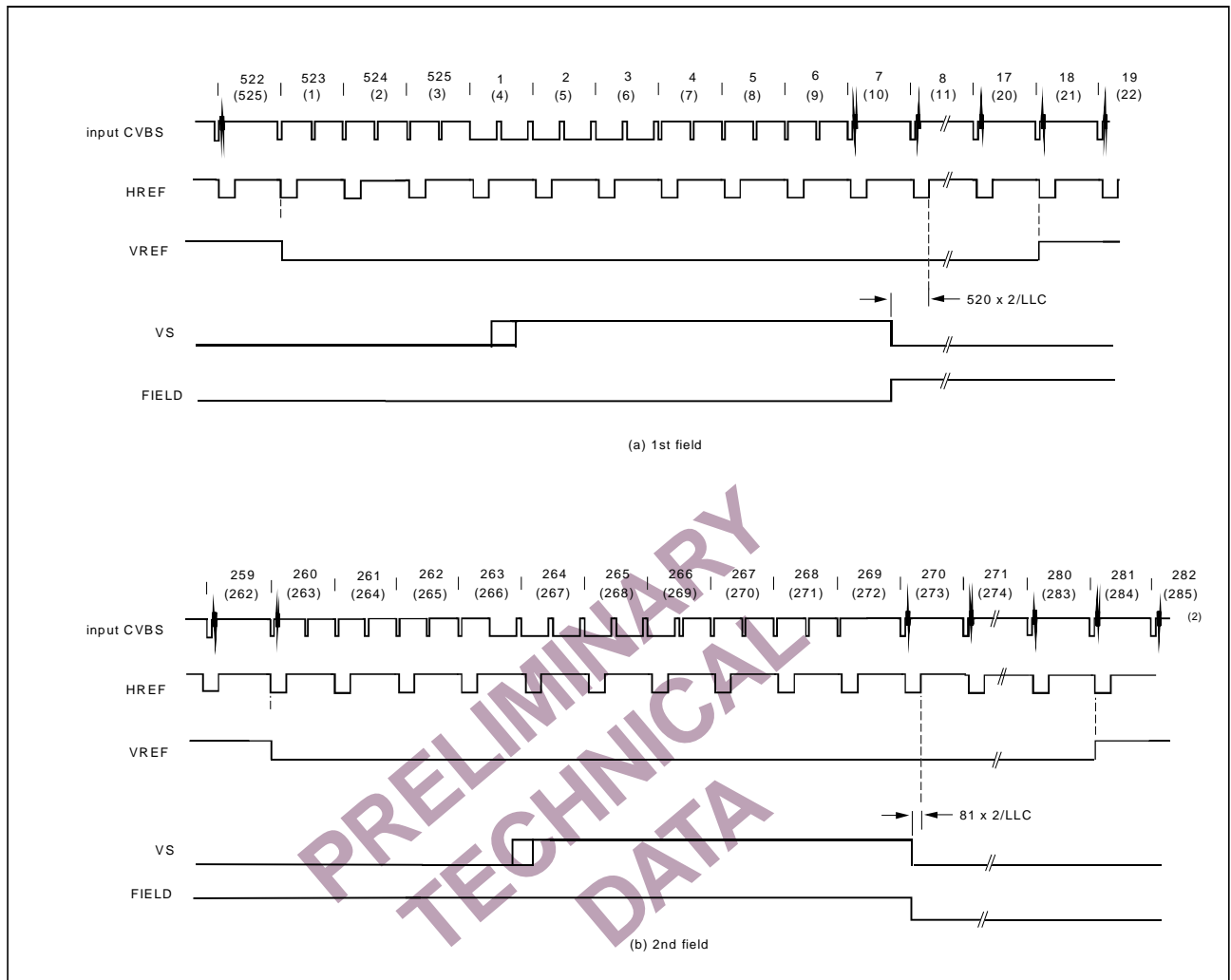

Figure 13. Vertical Timing Diagram 60Hz system

LUMINANCE SHAPING FILTER L PLOTS

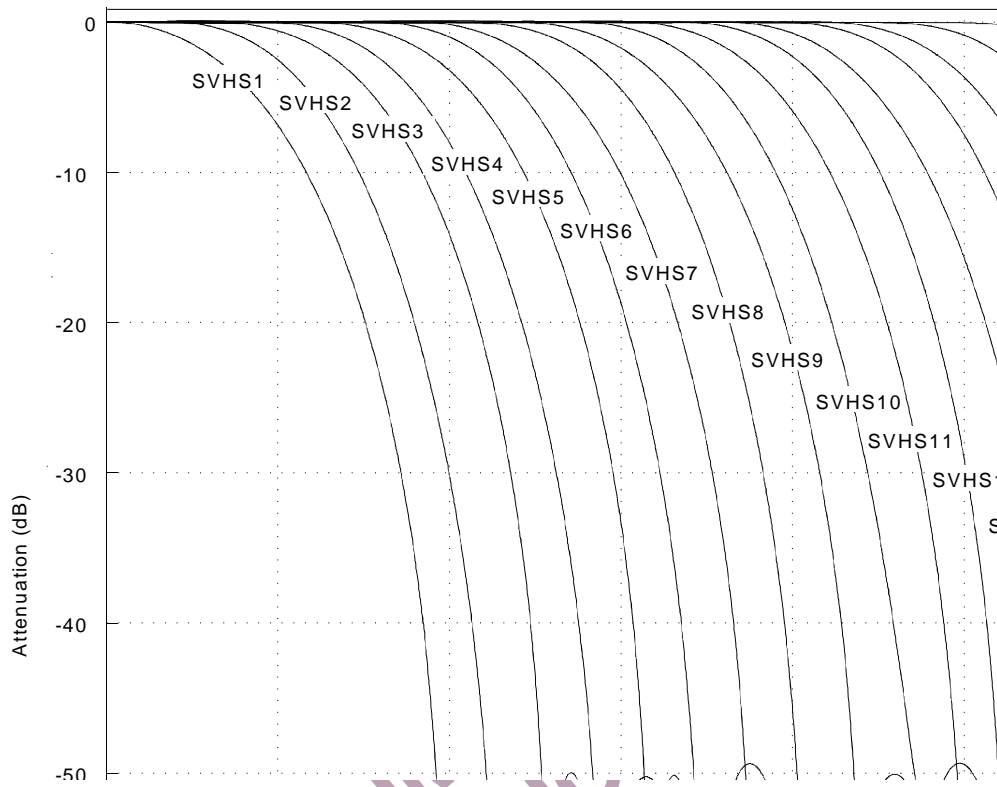

Figure xx. Luminance SVHS1-17 shaping filter responses

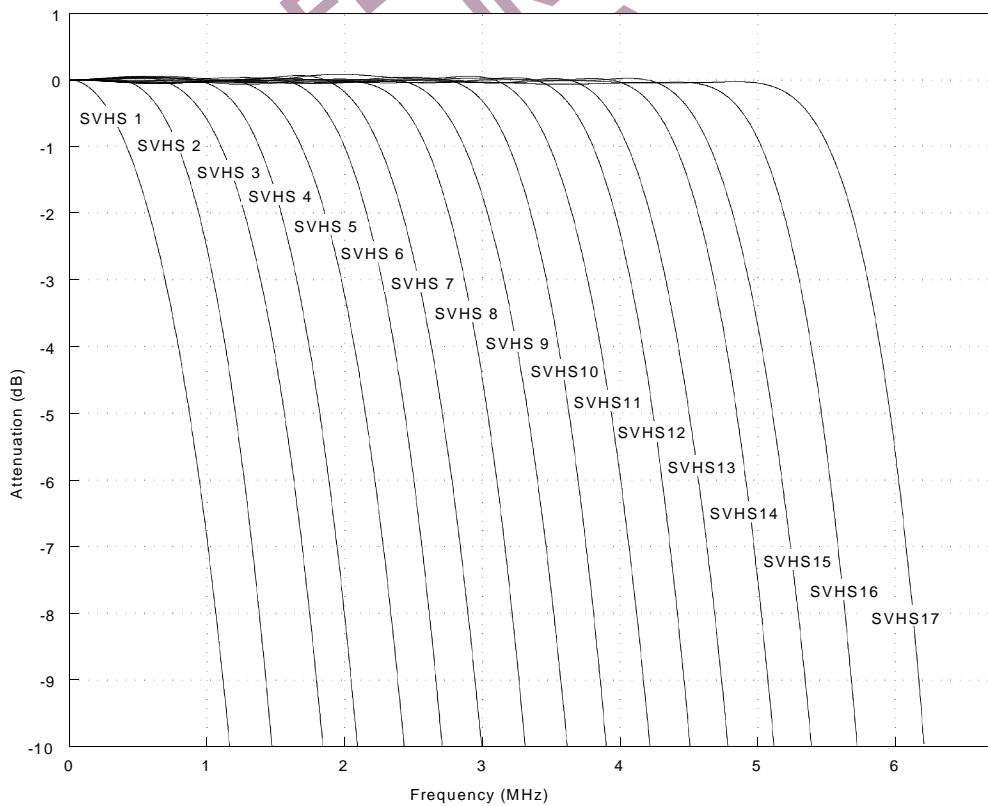

Figure xx. Luminance SVHS1-17 shaping filter responses (closeup)

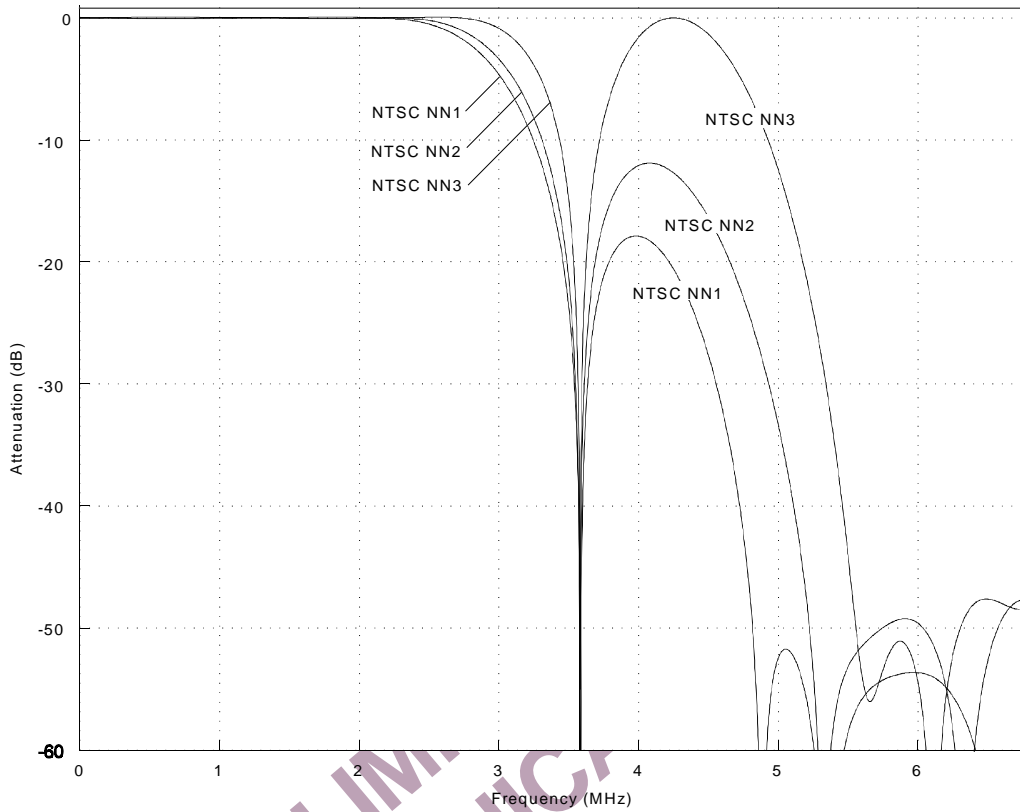

Figure xx. Luminance NTSC Narrow Notch shaping filter responses

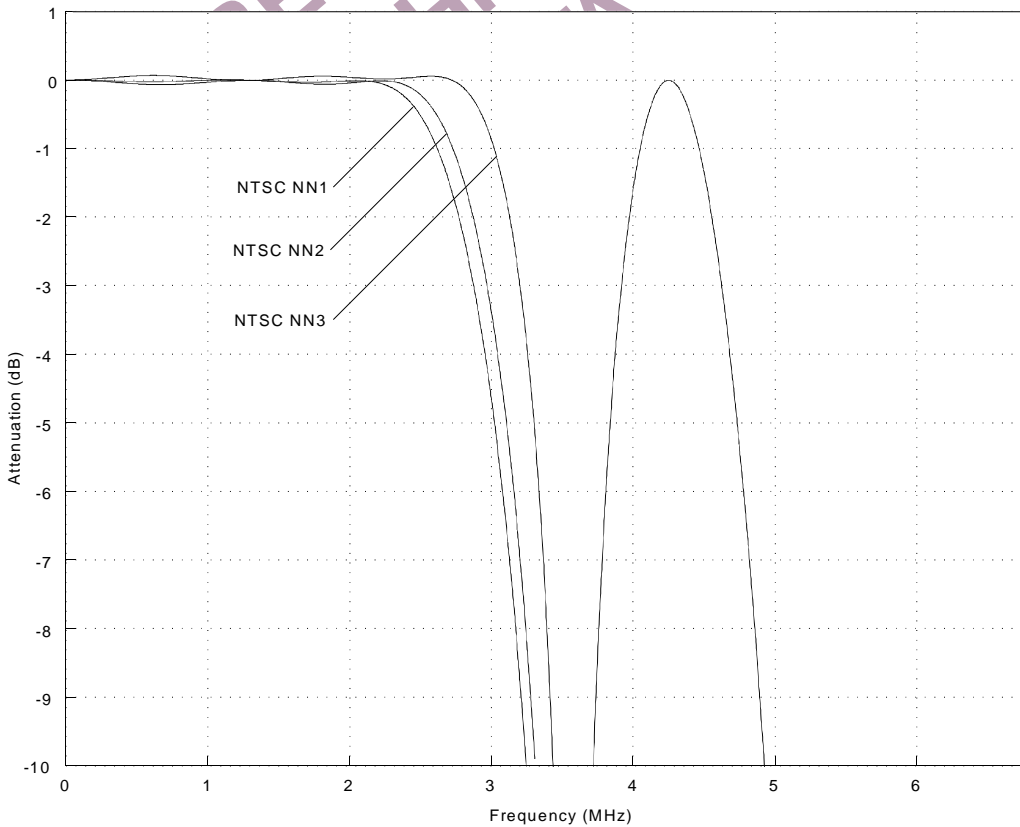

Figure xx. Luminance NTSC Narrow Notch shaping filter responses (closeup)

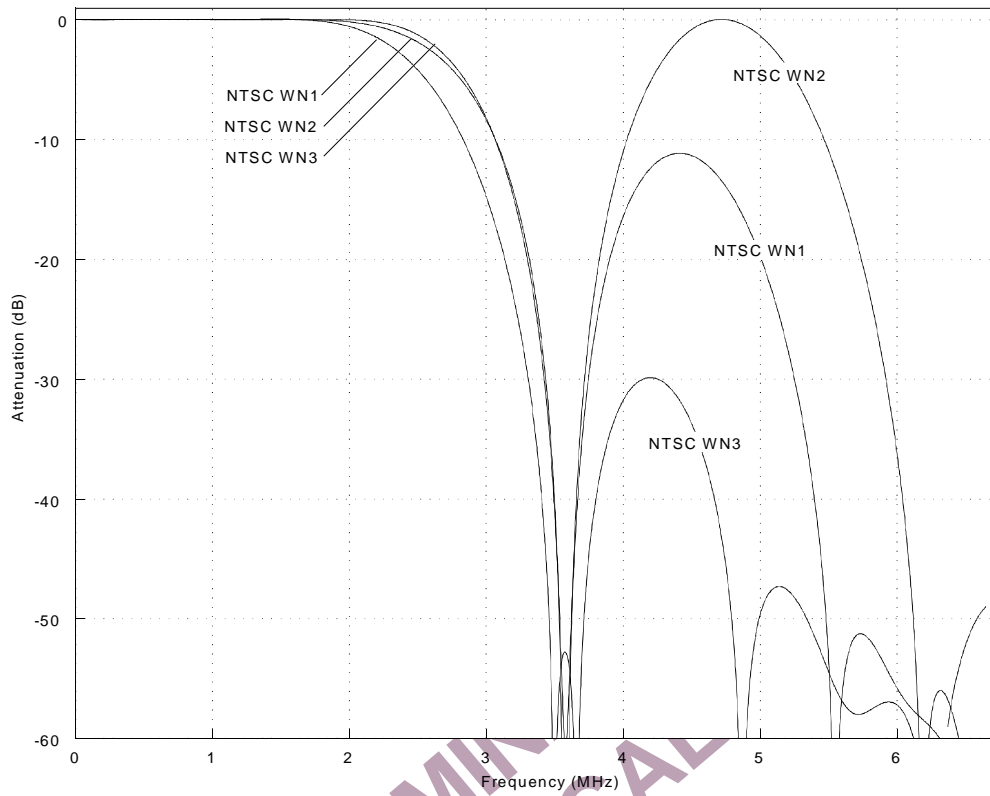

Figure xx. Luminance NTSC Wide Notch shaping filter responses

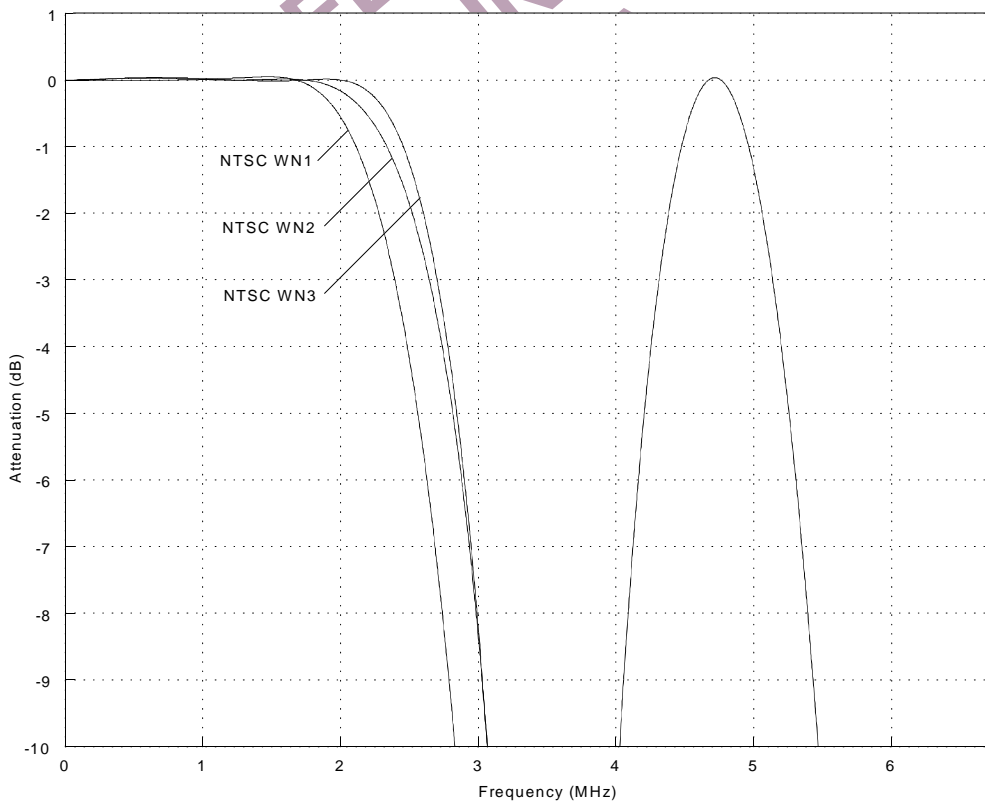

Figure xx. Luminance NTSC Wide Notch shaping filter responses (closeup)

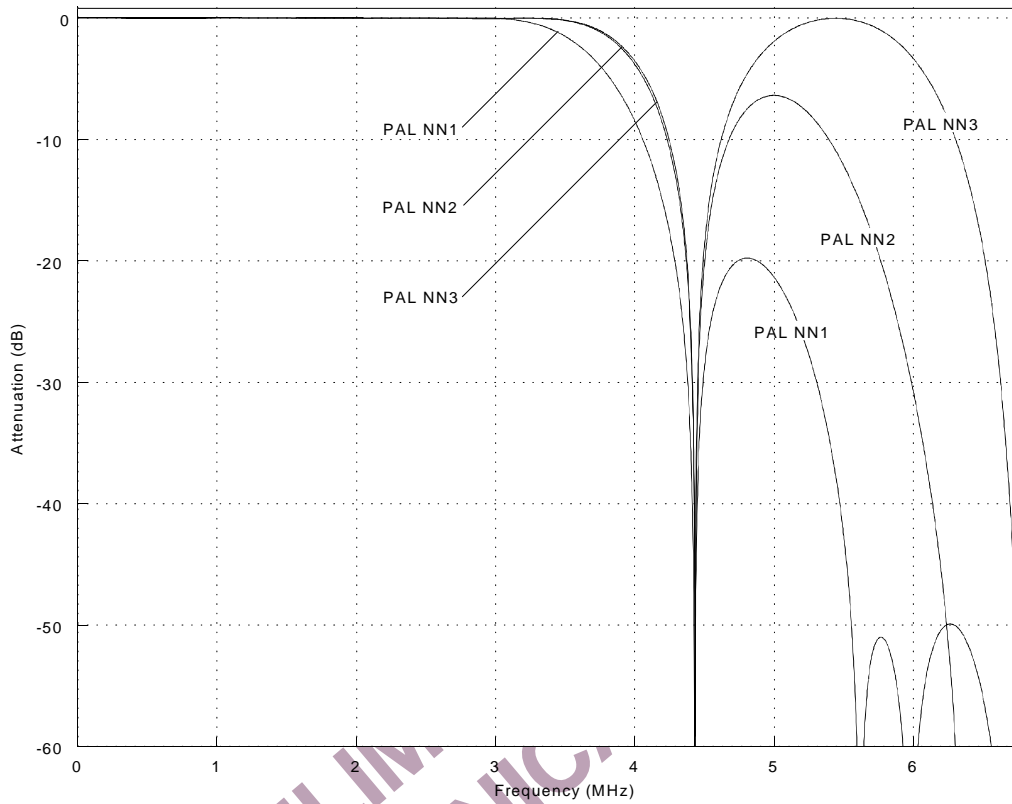

Figure xx. Luminance PAL Narrow Notch shaping filter responses

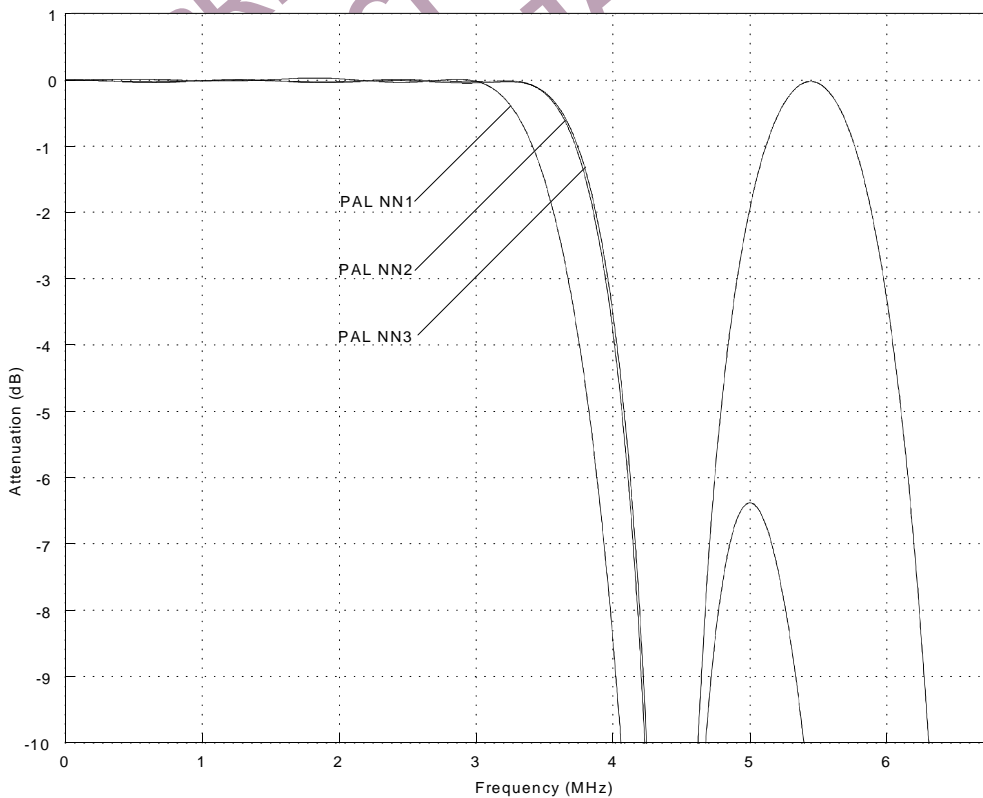

Figure xx. Luminance PAL Narrow Notch shaping filter responses (closeup)

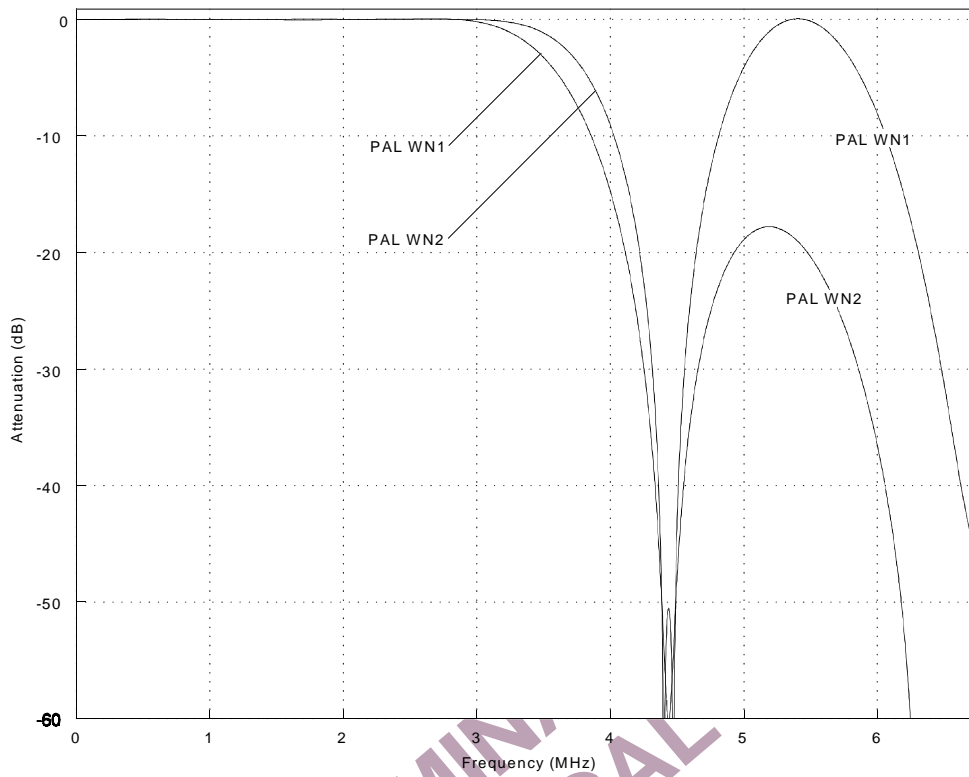

Figure xx. Luminance PAL Wide Notch shaping filter responses

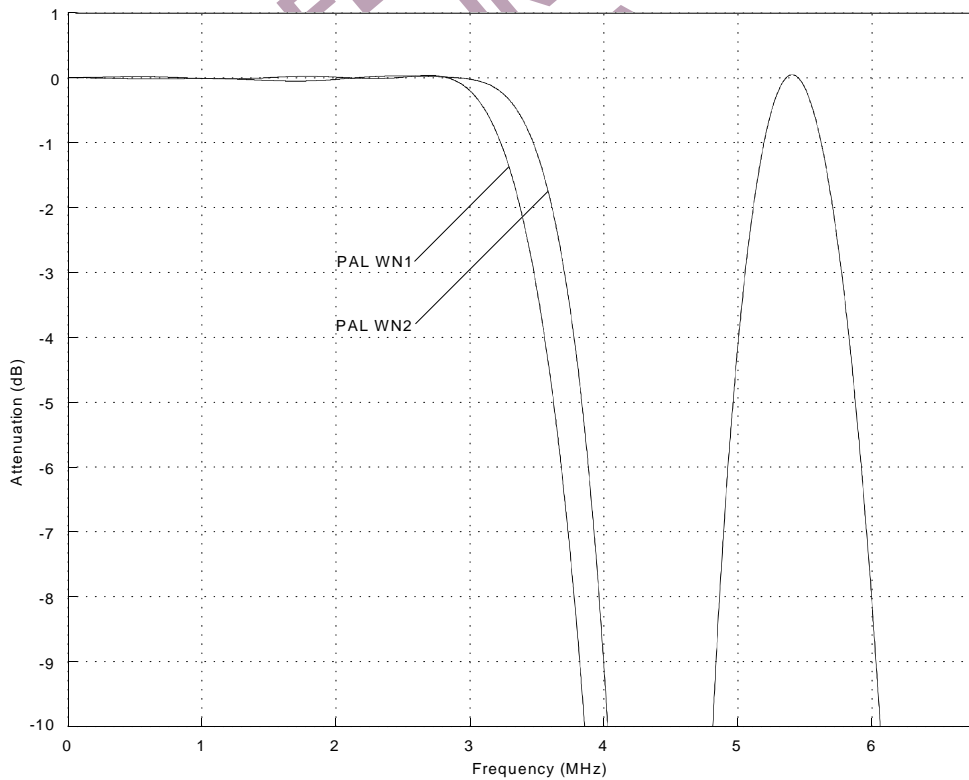

Figure xx. Luminance PAL Wide Notch shaping filter responses (closeup)

CHROMINANCE SHAPING FILTER L PLOTS

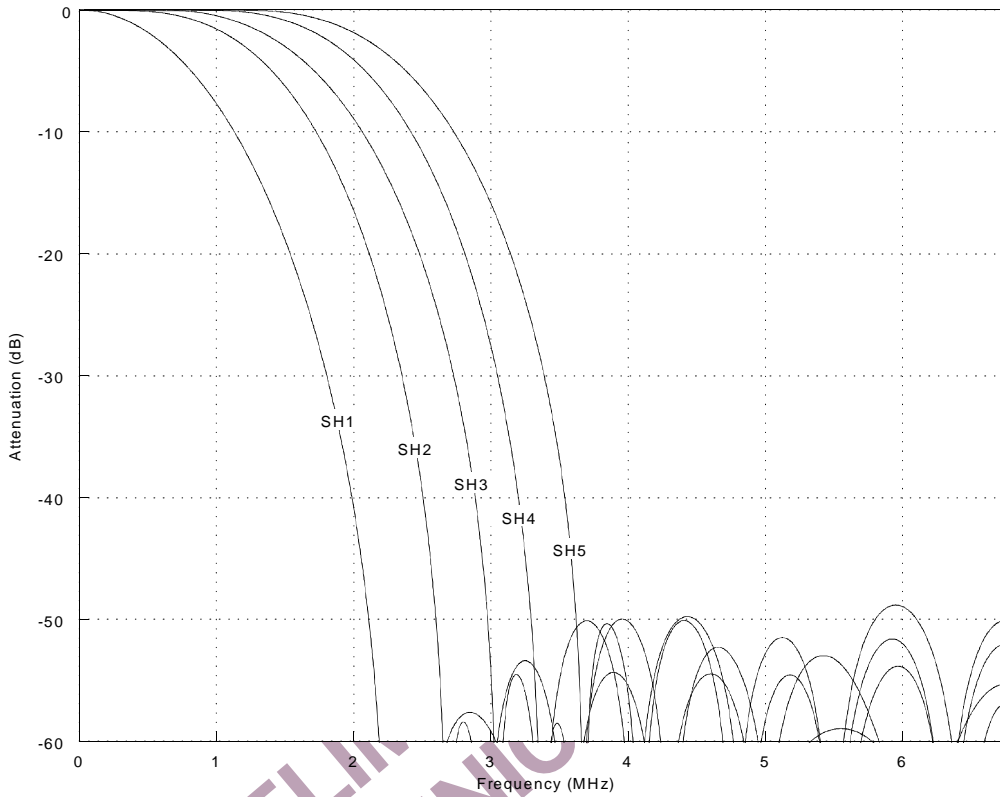

Figure xx. Chrominance shaping filter responses

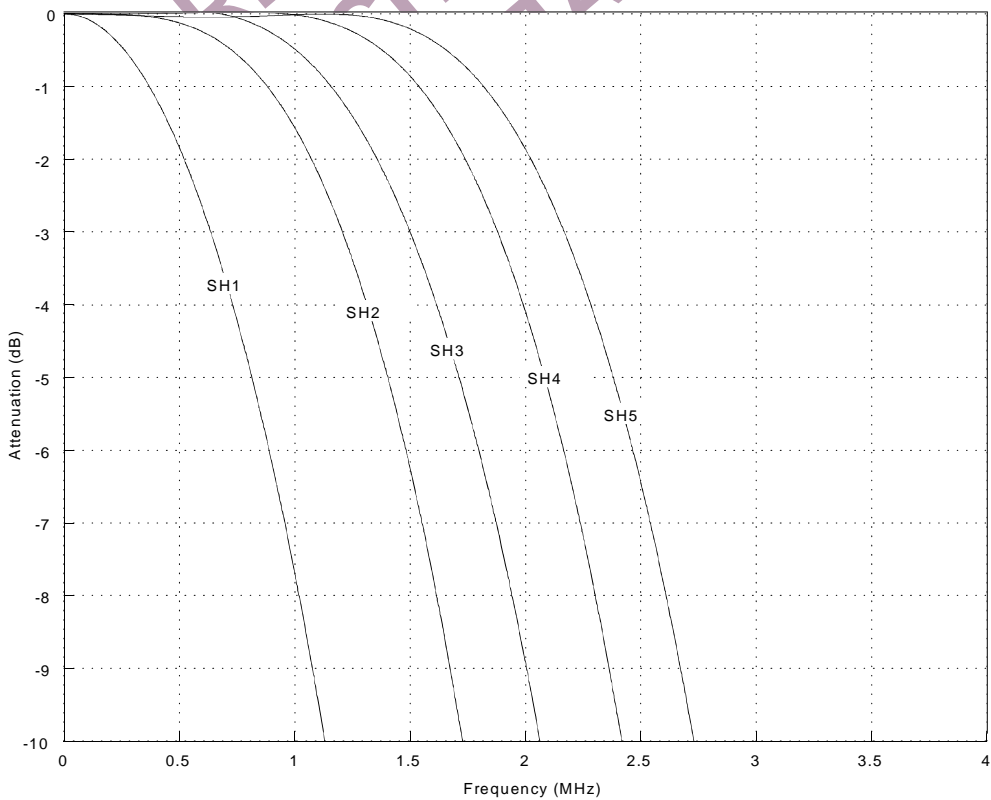

Figure xx. Chrominance shaping filter responses (closeup)

LUMINANCE PEAKING FILTER L PLOTS

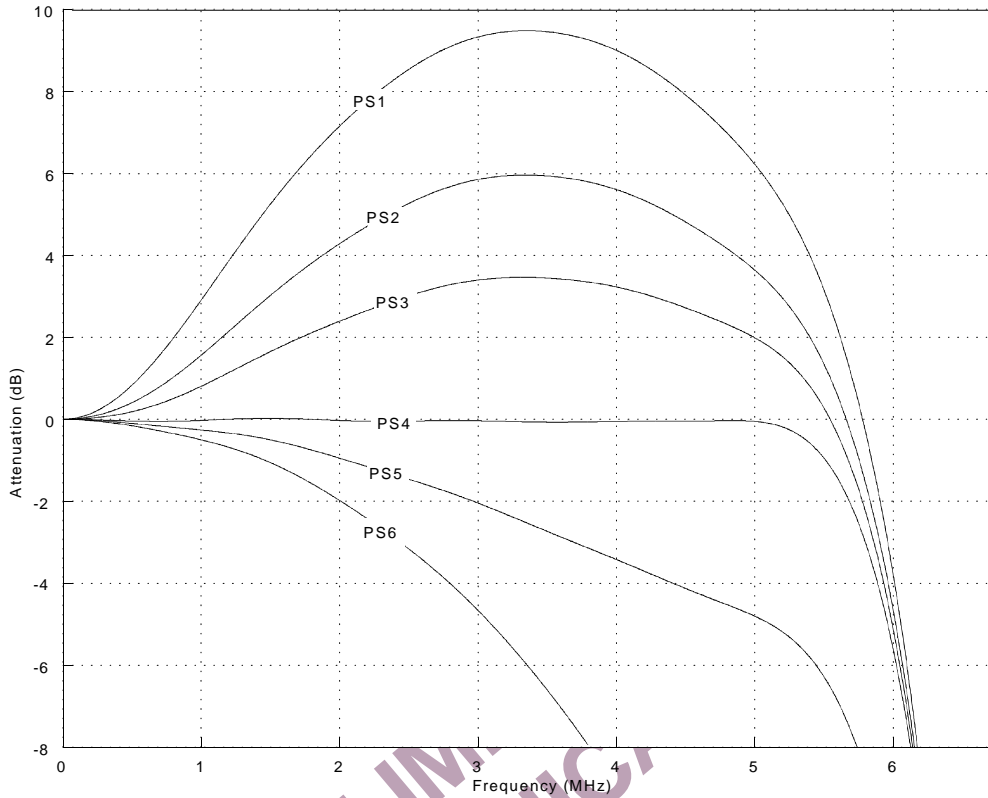

Figure xx. Luminance Peaking filter responses in S-Video (SVHS17 selected)

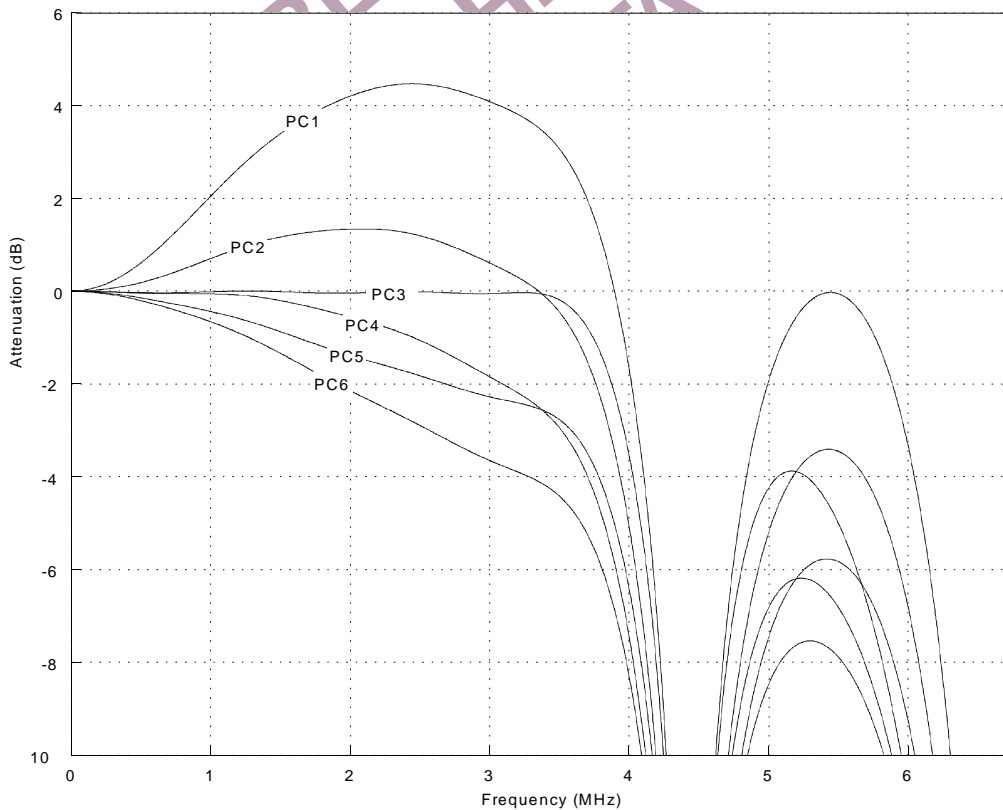

Figure xx. Luminance Peaking filter responses in CVBS (PAL NN3 selected)

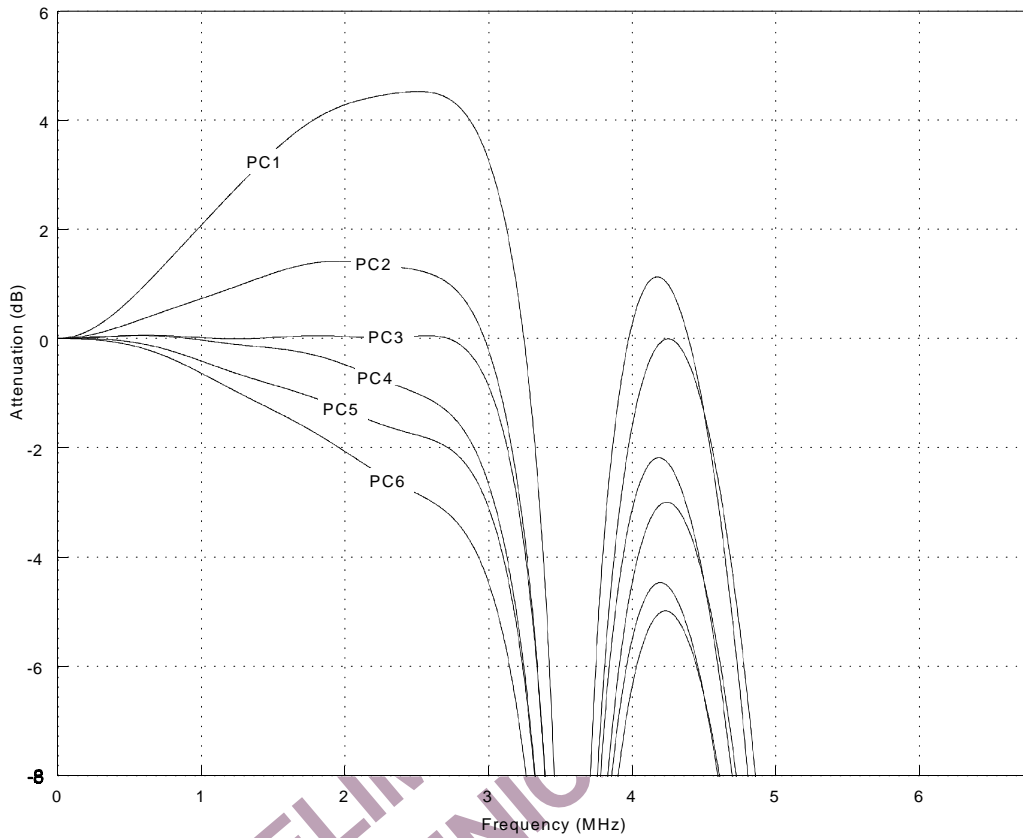

Figure xx. Luminance Peaking filter responses in CVBS (NTSC NN3 selected)

PRELIMINARY
TECHNICAL
DATA

IMPORTANT EQUATIONS

The following is a list of important equations:

$$CSFM[27:0] = \frac{F_{sc} \times 2^{28}}{XTAL \text{ Frequency}}$$

$$Chroma_Gain = \frac{(0 < CG \leq 4095)}{1024} = 0...4$$

$$Luma_Gain = \frac{(0 < LG \leq 4095)}{2048} = 0...4$$

$$End \ Input \ Horiz \ Window = AVHB + \frac{(N_{NOM} \times HSCV)}{2^{21}} \times AVDP$$

$$End \ Input \ Vertical \ Window = AVHB + \left(\frac{VSCV}{2^8} \times LCD \right) \times AVDL$$

$$Horizontal \ Scaling = \left(\frac{N_{NOM} \times HSCV}{2^{21}} \right) \times AVDL$$

$$Y_{OUT} = \left(\frac{CONTRAST}{128} \times (Y - 128) \right) + (BRIGHTNESS \times 8)$$

$$UV_{OUT} = \left(\frac{SATURATION}{128} \times (Cr, Cb - 128) \right) + 128$$

$$CLKVAL = \frac{f_{LLC}}{27 \times 10^6} \times \frac{2^{24}}{1728}$$

PRELIMINARY
TECHNICAL
DATA

MPU PORT DESCRIPTION.

The ADV7185 support a two wire serial (I²C Compatible) microprocessor bus driving multiple peripherals. Two inputs Serial Data (SDATA) and Serial Clock (SCLOCK) carry information between any device connected to the bus. Each slave device is recognised by a unique address. The ADV7185 has two possible slave addresses for both read and write operations. These are unique addresses for the device and are illustrated in Figure xx. The LSB sets either a read or write operation. Logic level "1" corresponds to a read operation while logic level "0" corresponds to a write operation. A1 is set by setting the ALSB pin of the ADV7185 to logic level "0" or logic level "1".

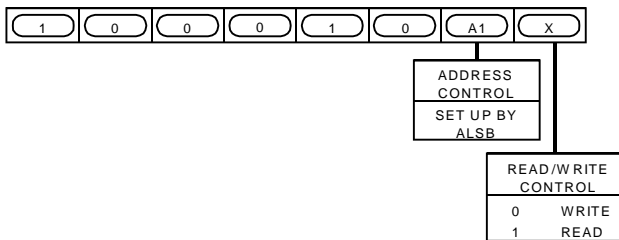

Fig xx. ADV7185 Slave Address

To control the device on the bus the following protocol must be followed. First the master initiates a data transfer by establishing a Start condition, defined by a high to low transition on SDATA whilst SCLOCK remains high. This indicates that an address/data stream will follow. All peripherals respond to the Start condition and shift the next eight bits (7-Bit address + R/W bit). The bits transferred from MSB down to LSB. The peripheral that recognises the transmitted address responds by pulling the data line low during the ninth clock pulse. This is known as an acknowledge bit. All other devices withdraw from the bus at this point and maintain an idle condition. The idle condition is where the device monitors the SDATA and SCLOCK lines waiting for the Start condition and the correct transmitted address. The R/W bit determines the direction of the data. A logic "0" on the LSB of the first

byte means that the master will write information to the peripheral. A logic "1" on the LSB of the first byte means that the master will read information from the peripheral.

The ADV7185 acts as a standard slave device on the bus. The data on the SDATA pin is 8 bits long supporting the 7-Bit addresses plus the R/W bit. The ADV7185 has 71 subaddresses to enable access to the internal registers. It therefore interprets the first byte as the device address and the second byte as the starting subaddress. The subaddresses auto increment allowing data to be written to or read from from the starting subaddress. A data transfer is always terminated by a Stop condition. The user can also access any unique subaddress register on a one by one basis without having to update all the registers.

Stop and Start conditions can be detected at any stage during the data transfer. If these conditions are asserted out of sequence with normal read and write operations, then these cause an immediate jump to the idle condition. During a given SCLOCK high period the user should only issue one Start condition, one Stop condition or a single Stop condition followed by a single Start condition. If an invalid subaddress is issued by the user, the ADV7185 will not issue an acknowledge and will return to the idle condition. If in auto-increment mode, the user exceeds the highest subaddress then the following action will be taken:

1. In Read Mode the highest subaddress register contents will continue to be output until the master device issues a no-acknowledge. This indicates the end of a read. A no-acknowledge condition is where the SDATA line is not pulled low on the ninth pulse.
2. In Write Mode, the data for the invalid byte will be not be loaded into any subaddress register, a no-acknowledge will be issued by the ADV7185 and the part will return to the idle condition.

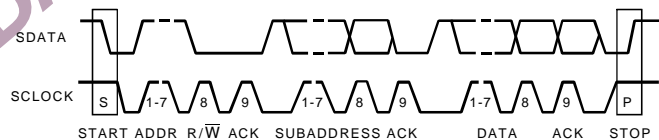

Figure yy. Bus Data Transfer

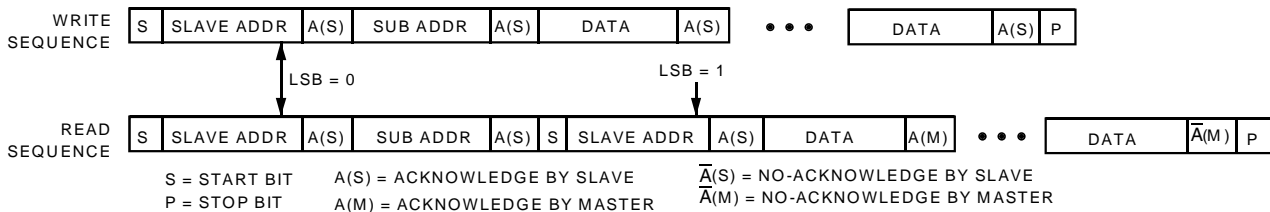

Figure 35 Illustrates an example of data transfer for a read sequence and the Start and Stop conditions.

Figure 36. Write and Read Sequences

REGISTER ACCESSES

The MPU can write to or read from all of the registers of the ADV7185 except the Subaddress Register which is a write only register. The Subaddress Register determines which register the next read or write operation accesses. All communications with the part through the bus start with an access to the Subaddress Register. Then a read/write operation is performed from/to the target address which then increments to the next address until a Stop command on the bus is performed.

REGISTER PROGRAMMING

The following section describes each register in terms of its configuration.

Subaddress Register (SR7-SR0)

The Communications Register is an eight bit write-only register. After the part has been accessed over the bus and a read/write operation is selected, the subaddress is set up. The Subaddress Register determines to/from which register the operation takes place.

Figure 37 shows the various operations under the control of the Subaddress Register. Zero should always be written to SR7-SR6.

Register Select (SR5-SR0):

These bits are set up to point to the required starting address.

Register Name	Subaddress(Hex)
BASIC BLOCK	
Input Control	00
Video Selection	01
Video Enhancement Control	02
Output Control	03
Extended Output Control	04
General Purpose Output	05
Reserved	06
FIFO Control	07
Contrast Control	08
Saturation Control	09
Brightness Control	0A
Hue Control	0B
Default Value Y	0C
Default Value C	0D
Temporal Decimation	0E
Power Management	0F
Status Register	10
Info Register	11
ADVANCED BLOCK	
Reserved	12
Reserved	13
Analog Clamp Control	14
Digital Clamp Control 1	15
Digital Clamp Control 2	16
Shaping Filter Control	17
Reserved	18
Comb Filter Control	19
Scaling/Cropping MSB	1A
Active Video Desired Lines	1B
Active Video Vertical Begin	1C

Register Name	Subaddress(Hex)
ADVANCED BLOCK	
Vertical Scale Value 1	1D
Vertical Scale Value 2	1E
Active Video Horiz Begin	1F
Active Video desired Pixel	20
Horizontal Scale Value1	21
Horizontal Scale Value2	22
Reserved	23
Color Subcarrier Control 1	24
Color Subcarrier Control 2	25
Color Subcarrier Control 3	26
Color Subcarrier Control 4	27
Pixel Delay Control	28
Manual Clock Control 1	29
Manual Clock Control 2	2A
Auto Clock Control	2B
AGC Mode Control	2C
Chroma Gain Control 1	2D
Chroma Gain Control 2	2E
Luma Gain Control 1	2F
Luma Gain Control 2	30
Manual Gain Shadow Control 1	31
Manual Gain Shadow Control 2	32
Misc Gain Control	33
Hsync Position Control 1	34
Hsync Position Control 2	35
Hsync Position Control 3	36
Polarity Control	37
Reserved	38
Reserved	39
Reserved	3A
Reserved	

Figure 37. Subaddress Register

Table 1.0 Basic Registers

Register Name	addr (Hex)	D7	D6	D5	D4	D3	D2	D1	D0
Input Control	00	VID SEL.3	VID SEL.2	VID SEL.1	VID SEL.0	INSEL.3	INSEL.2	INSEL.1	INSEL.0
Video Selection	01	ASE	-	-	-	DIFFIN	SQPE	VID QUAL.1	VID QUAL.0
Video Enhancement Control	02	-	-	-	COR.1	COR.0	YPM.2	YPM.1	YPM.0
Output Control	03	VBLEN	TOD	OF SEL.3	OF SEL.2	OF SEL.1	OF SEL.0	OM SEL.1	OMEL.0
Extended Output Control	04	-	-	-	-	-	-	-	RANGE
General Purpose Output	05	-	-	GPEH	GPEL	GP0.3	GP0.2	GP0.1	GP0.0
Reserved	06	-	-	-	-	-	-	-	-
FIFO Control	07	FFST	AFR	FR	FFM.4	FFM.3	FFM.2	FFM.1	FFM.0
Contrast Control	08	CON.7	CON.6	CON.5	CON.4	CON.3	CON.2	CON.1	CON.0
Saturation Control	09	SAT.7	SAT.6	SAT.5	SAT.4	SAT.3	SAT.2	SAT.1	SAT.0
Brightness Control	0A	BRI.7	BRI.6	BRI.5	BRI.4	BRI.3	BRI.2	BRI.1	BRI.0
Hue Control	0B	HUE.7	HUE.6	HUE.5	HUE.4	HUE.3	HUE.2	HUE.1	HUE.0
Default Value Y	0C	DEF Y.5	DEF Y.4	DEF Y.3	DEF Y.2	DEF Y.1	DEF Y.0	DEF_AUTO_EN	DEF_VAL_EN
Default Value C	0D	DEF C.7	DEF C.6	DEF C.5	DEF C.4	DEF C.3	DEF C.2	DEF C.1	DEF C.0
Temporal Decimation	0E	-	TDR.3	TDR.2	TDR.1	TDR.0	TDC.1	TDC.0	TDE
Power Management	0F	RES	TRAQ	PWRDN	PS CG	PS REF	PDBP	PSC.1	PSC.0
Status Register	10	STATUS.7	STATUS.6	STATUS.5	STATUS.4	STATUS.3	STATUS.2	STATUS.1	STATUS.0
Info Register	11	-	-	-	-	-	IDENT.2	IDENT.1	IDENT.0

Table 2.0 Advanced Registers

Register Name	addr (Hex)	D7	D6	D5	D4	D3	D2	D1	D0
Reserved	12	-	-	-	-	-	-	-	-
Reserved	13	-	-	-	-	-	-	-	-
Analog Clamp Control	14	-	-	VCLEN	CCLEN	FACL.1	FACL.0	FICL.1	FICL.0
Digital Clamp Control 1	15	DCCM	DCT.1	DCT.0	DCFE	DCC0.11	DCC0.10	DCC0.9	DCC0.8
Digital Clamp Control 2	16	DCC0.7	DCC0.6	DCC0.5	DCC0.4	DCC0.3	DCC0.2	DCC0.1	DCC0.0
Shaping Filter Control	17	GSFM.2	GSFM.1	CSFM.0	YSFM.4	YSFM.3	YSFM.2	YSFM.1	YSFM.0
Reserved	18	-	-	-	-	-	-	-	-
Comb Filter Control	19	-	-	-	CCMB_AD	CCM.1	CCM.0	LCM.1	LCM.0
Scaling/Cropping MSB	1A	AVDL.8	AVVB.8	AVHB.9	AVDP.9	AVDP.8	-	-	SCE
Active Video Desired Lines	1B	AVDL.7	AVDL.6	AVDL.5	AVDL.4	AVDL.3	AVDL.2	AVDL.1	AVDL.0
Active Video Vertical Begin	1C	AVVB.8	AVVB.7	AVVB.6	AVVB.5	AVVB.4	AVVB.3	AVVB.2	AVVB.1
Vertical Scale Value 1	1D	-	-	-	-	-	VSCV.10	VSCV.9	VSCV.8
Vertical Scale Value 2	1E	VSCV.7	VSCV.6	VSCV.5	VSCV.4	VSCV.3	VSCV.2	VSCV.1	VSCV.0
Active Video Horiz Begin	1F	AVHB.7	AVHB.6	AVHB.5	AVHB.4	AVHB.3	AVHB.2	AVHB.1	AVHB.0
Active Video desired Pixel	20	AVDP.7	AVDP.6	AVDP.5	AVDP.4	AVDP.3	AVDP.2	AVDP.1	AVDP.0
Horizontal Scale Value1	21	HSCV.15	HSCV.14	HSCV.13	HSCV.12	HSCV.11	HSCV.10	HSCV.9	HSCV.8
Horizontal Scale Value2	22	HSCV.7	HSCV.6	HSCV.5	HSCV.4	HSCV.3	HSCV.2	HSCV.1	HSCV.0
Reserved	23	-	-	-	-	-	-	-	-
Color Subcarrier Control 1	24	-	-	-	CSM	CSMF.27	CSMF.26	CSMF.25	CSMF.24
Color Subcarrier Control 2	25	CSMF.23	CSMF.22	CSMF.21	CSMF.20	CSMF.19	CSMF.18	CSMF.17	CSMF.16
Color Subcarrier Control 3	26	CSMF.15	CSMF.14	CSMF.13	CSMF.12	CSMF.11	CSMF.10	CSMF.9	CSMF.8
Color Subcarrier Control 4	27	CSMF.7	CSMF.6	CSMF.5	CSMF.4	CSMF.3	CSMF.2	CSMF.1	CSMF.0

Table 2.1 Advanced Registers Continued

Register Name	addr (Hex)	D7	D6	D5	D4	D3	D2	D1	D0
Pixel Delay Control	28	SWPC	-	CTA.2	CTA.1	CTA.0	-	-	-
Manual Clock Control 1	29	FIX27E	CLKMANE	CLKVAL.13	CLKVAL.12	CLKVAL.11	CLKVAL.10	CLKVAL.9	CLKVAL.8
Manual Clock Control 2	2A	CLKVAL.7	CLKVAL.6	CLKVA5L.13	CLKVAL.4	CLKVAL.3	CLKVAL.2	CLKVAL.1	CLKVAL.0
Reserved	2B	-	-	-	-	-	-	-	-
AGC Mode Control	2C	-	LAGC.2	LAGC.1	LAGC.0	-	-	CAGC.1	CAGC.0
Chroma Gain Control 1	2D	CAGT.1	CAGT.0	-	-	CMG.11	CMG.10	CMG.9	CMG.8
Chroma Gain Control 2	2E	CMG.7	CMG.6	CMG.5	CMG.4	CMG.3	CMG.2	CMG.1	CMG.0
Luma Gain Control 1	2F	LAGT.1	LAGT.0	-	-	LMG.11	LMG.10	LMG.9	LMG.8
Luma Gain Control 2	30	LMG.7	LMG.6	LMG.5	LMG.4	LMG.3	LMG.2	LMG.1	LMG.0
Manual Gain Shadow Control 1	31	SGUE	-	-	-	LMGS.11	LMGS.10	LMGS.9	LMGS.8
Manual Gain Shadow Control 2	32	LMGS.7	LMGS.6	LMGS.5	LMGS.4	LMGS.3	LMGS.2	LMGS.1	LMGS.0
Misc Gain Control	33	-	CKE	-	MIRE.2	MIRE.1	MIRE.0	AV_AL	PW_UPD
Hsync Position Control 1	34	HSB.9	HSB.8	HSE.9	HSE.8	-	-	-	-
Hsync Position Control 2	35	HSB.7	HSB.6	HSB.5	HSB.4	HSB.3	HSB.2	HSB.1	HSB.0
Hsync Position Control 3	36	HSE.7	HSE.6	HSE.5	HSE.4	HSE.3	HSE.2	HSE.1	HSE.0
Reserved	37	-	-	-	-	-	-	-	-
Reserved	38	-	-	-	-	-	-	-	-
Reserved	39	-	-	-	-	-	-	-	-
Reserved	3A	-	-	-	-	-	-	-	-

BASIC USER REGISTER MAP

INPUT CONTROL (SUBADDRESS 00H)

INSEL[3:0] VIDEO INPUT CHANNEL SELECTION (D3-D0)

The INSEL bits allow the user to select an input channel as well as the input format for that channel. The ADV7185 can be configured as having 6 CVBS inputs , 3 S-Video inputs and 2 YUV inputs or any combination of CVBS, S-vVideo and YUV when combined give a total to six channels (e.g. 1 CVBS[1 channel], 1 S-Video [2 channels] & 1 YUV [3 channels]).

INSEL.3	INSEL.2	INSEL.1	INSEL.0	I/P Pins Selected	Video Format
0	0	0	0	A1	CVBS
0	0	0	1	A2	CVBS
0	0	1	0	A3	CVBS
0	0	1	1	A4	CVBS
0	1	0	0	A5	CVBS
0	1	0	1	A6	CVBS
0	1	1	0	Y1 = A1 C1 = A4	S-Video
0	1	1	1	Y2 = A2 C2 = A5	S-Video
1	0	0	0	Y3 = A3 C3 = A6	S-Video
1	0	0	1	Y1 = A1 U1 = A4 V1 = A5	YUV
1	0	1	0	Y2 = A2 U2 = A3 V2 = A6	YUV
1	0	1	1	No I/P	Free Run
1	1	0	0	-	-
1	1	0	1	-	-
1	1	1	0	-	-
1	1	1	1	-	-

Table xx. Input Selection Table

VID_SEL[3:0] VIDEO INPUT STANDARD SELECTION (D7-D4)

The VID_SEL bits allow the user to select the decode standard for the selected input channel. The ADV7185 is configured to decode the input video as per the standard selected. There are also 4 autodetect modes which will automatically switch between one of the two possible standards for the selected mode. For example if VID_SEL[3:0] = 0010 and a PAL N source is connected, and the user switches the source to a PAL M (without pedestal) the ADV7185 will automatically detect this change without any input from the user and decode the video accordingly. The non-autodetect modes simply decode the selected standard only, the mode will have to be changed by the user if a different standard source is connected to the decoder.

VID_SEL.3	VID_SEL.2	VID_SEL.1	VID_SEL.0	Video Format
0	0	0	0	Autodetect (PAL BGHID) - NTSC M (without pedestal)
0	0	0	1	Autodetect (PAL BGHID) - NTSC M (with pedestal)
0	0	1	0	Autodetect (PAL N) - NTSC M (without pedestal)
0	0	1	1	Autodetect (PAL N) - NTSC M (with pedestal)
0	1	0	0	NTSC M (without pedestal)
0	1	0	1	NTSC M (with pedestal)
0	1	1	0	NTSC 4.43 (without pedestal)
0	1	1	1	NTSC 4.43 (with pedestal)
1	0	0	0	PAL BGHID (without pedestal)
1	0	0	1	PAL N (= PAL BGHID (without pedestal))
1	0	1	0	PAL M (without pedestal)
1	0	1	1	PAL M (with pedestal)
1	1	0	0	PAL combination N
1	1	0	1	PAL combination N (with pedestal)
1	1	1	0	Reserved
1	1	1	1	Reserved

Table xx. Input Video Standard Selection Table

VIDEO SELECTION (SUBADDRESS 01H)

ASE AUTOMATIC STARTUP ENABLE (D7)

This ASE bit is used to trigger a re-acquire in the ADV7185, this will result in the decoder rellocking to a new video source and extracting the new timing information from this source. If this bit is set to 1 then on a change in INSEL the decoder will automatically start a re-acquire of the new video source. This enables faster locking to the new video source. Note this bit should be set to 0 when using Genlock mode.

ASE	Function
0	If INSEL changes it will not cause a re-acquire by the decoder
1	If INSEL changes it will trigger a re-acquire by the decoder

Table xx. Automatic Startup Enable

DIFFIN DIFFERENTIAL INPUT (D3)

This DIFFIN bit is used to enable Differential Inputs to the ADV7185. When using the part in 10bit Extended CCIR656 mode the user may wish to use differential inputs to improve the Video Channel performance if there is a significant amount of system noise. A logic 1 enables the differential input mode.

DIFFIN	Function
0	Decode each input channel as a single ended source
1	Decode each input channel as a differential source

Table xx. Differential Input Selection

SQPE SQUARE PIXEL ENABLE (D2)

This SQPE bit when set to a logic 1 enables SQUARE PIXEL mode. This mode outputs the Video data (P19 : P0) at a clock rates of 24.5454MHz for NTSC and 29.5MHz for PAL. When SQPE is set to a logic 0 the decoder outputs the video data (P19 : 0) at the CCIR656 Clock rate of 27MHz for both PAL and NTSC.

SQPE	Function
0	Select standard 27MHz CCIR656 mode
1	Select Square Pixel mode (24.5454Mhz NTSC 29.5MHz PAL)

Table xx. Square Pixel Enable

VID_QUAL VIDEO QUALITY SELECTION (D1-D0)

The VID_QUAL bits are used to select the type of video source being decoded by the ADV7185. The ADV7185 can decode the video more effectively when the user programs the desired video input type being decoded. For whichever video source is selected the decoder will adapt according and deliver the maximum performance for the selected video source. Table xx shows the four possible modes the ADV7185 can be configured to.

VID_QUAL.1	VID_QUAL.0	Function
0	0	Configures decoder to decode Broadcast quality video stable signal amplitudes and timing
0	1	Configures decoder to decode TV quality video variable signal amplitudes and stable timing
1	0	Configures decoder to decode VCRT quality video variable signal amplitudes and instable timing
1	1	Configures decoder to decode Broadcast quality video variable signal amplitudes, stable timing and fast acquire

Table xx. Automatic Startup Enable

VIDEO ENHANCEMENT CONTROL (SUBADDRESS 02H)

COR[1 : 0] CORING SELECTION (D4-D3)

This COR[1 : 0] bits are used to control optional Coring of the Luminance output signal depending on its level, see Table xx below for options. Coring is used to reduce visual artefacts within black areas of the screen by clipping values to 0 if they are below a certain threshold.

COR1	COR0	Function
0	0	No coring
0	1	Truncate if Y value is less than black +8
1	0	Truncate if Y value is less than black +16
1	1	Truncate if Y value is less than black +32

Table xx. Coring Selection

YPM[2 : 0] LUMINANCE PEAKING FILTER MODES (D2-D0)

The YPM[2 : 0] bits are used to select the Luminance Peaking filter response, Table xx shows the available response selections. These filters enables luma boost / attenuation of the signal centred around the color subcarrier frequency of both PAL and NTSC frequencies. These filters have the effect of enhancing the picture and improving the picture contrast.

YPM2	YPM1	YPM0	Filter Responses	
			CVBS mode	S-Video Mode
0	0	0	PC1	PS1
0	0	1	PC1	PS1
0	1	0	PC1	PS2
0	1	1	PC2	PS3
1	0	0	PC3	PS4
1	0	1	PC4	PS5
1	1	0	PC5	PS6
1	1	1	PC6	PS6

Table xx. Luminance Peaking Filter Modes

OUTPUT CONTROL (SUBADDRESS 03H)

VBI VERTICAL BLANKING INTERVAL DATA ENABLE (D7)

This VBI enable bit allows data such as Closed Captioning and Intercast data to be passed through the Video Decoder with no filtering performed on the data. This data is often referred to as "RAW ADC Data". All data from lines 1 to 21 are passed through and available at the output port (P19 : P0). These VBI lines are marked as being invalid by the DVALVD signal.

VBI_EN	Function
0	All video lines including those in the VBI are filtered and scaleable
1	No scaling/filtering is allowed on VBI lines 1 to 21, VBI data is RAW ADC samples

Table xx. Vertical Blanking Interval Data Enable

TOD TRI-STATE OUTPUT DRIVERS (D6)

The tod bit allows the user to Tri-state the output drivers of the ADV7815 regardless of the \overline{OE} pin status.

TOD	Function
0	Output drivers working according to \overline{OE} pin polarity
1	Output drivers tri-state regardless of \overline{OE} pin

Table xx. Tri-state Output Enable

OF_SEL[3 : 0] OUTPUT FORMAT SELECTION (D5-D2)

The OF_SEL[3 : 0] bits are used to select the different pixel output formats for the decoder. Table xx shows all the possible pixel output configurations for the ADV7185.

OF_SEL3	OF_SEL2	OF_SEL1	OF_SEL0	Output Format	OUTPUT PORT PINS					P[19:0]			
					P[19 : 12]	P[11 : 10]	P[9 : 2]			P[1 : 0]			
							P[9 : 8]	P[7 : 6]	P[5 : 2]				
0	0	0	0	10bit @LLC1 4:2:2 CCIR656	Y[9 : 2] C[9 : 2]	Y[1 : 0] C[1 : 0]	tri-state	tri-state	tri-state				
0	0	0	1	20bit @LLC2 4:2:2 CCIR656	Y[9 : 2]	Y[1 : 0]	C[9 : 2]			C[1 : 0]			
0	0	1	0	16bit @LLC2 4:2:2 CCIR656	Y[7 : 0]	P[10]=GPO[2] P[11]=GPO[3]	C[7 : 0]			P[1]=GPO[1] P[0]=GPO[0]			
0	0	1	1	8bit @LLC1 4:2:2 CCIR656	Y[7 : 0] C[7 : 0]	P[10]=GPO[2] P[11]=GPO[3]	tri-state			P[1]=GPO[1] P[0]=GPO[0]			
0	1	0	0	12bit @LLC2 4:1:1	Y0[7 : 0] Y1[7 : 0] Y2[7 : 0] Y3[7 : 0]	P[10]=GPO[2] P[11]=GPO[3]	Cb[7 : 6] Cb[5 : 4] Cb[3 : 2] Cb[1 : 0]	Cr[7 : 6] Cr[5 : 4] Cr[3 : 2] Cr[1 : 0]	tri-state				
0	1	0	1	10bit @LLC1 4:2:2 CCIR656 10bit digitized composite in	Y[9 : 2] C[9 : 2]	Y[1 : 0] C[1 : 0]	tri-state			tri-state			
0	1	1	0	8bit @LLC1 10bit digitized composite in	Y[7 : 0] C[7 : 0]	P[10]=GPO[2] P[11]=GPO[3]	tri-state			tri-state			
0	1	1	1	-	-	-	-	-	-	-	-	-	-
1	1	1	1	-	-	-	-	-	-	-	-	-	-

Table xx. Output Format Selection

OM_SEL[1 : 0] OUTPUT FORMAT SELECTION (D1-D0)

The OM_SEL[1 : 0] bits are used to select the output mode in terms of the timing and the interface type. Table xx shows the three possible output modes and the mulit-function pin assignments.

OM_SEL1	OM_SEL0	FUNCTION	PIN FUNCTION AS RESULT OF MODE SELECTION				
			H, V, FIELD	HREF, VREF	RD	DV	HFF / QCLK / GL
0	0	Line Locked Clock Interface	H = HS V = VS FIELD = FIELD	HREF = HREF VREF = VFREF	n.c.	DV	GL
0	1	SCAPI Self Clocking Asynchronous Pixel Interface	H = HACTIVE V = VACTIVE FIELD = FIELD	HREF = $\overline{\text{HRESET}}$ VREF = $\overline{\text{VRESET}}$	n.c.	DVALID	QCLK
1	0	CAPI Clocked Asynchronous Pixel Interface	H = HACTIVE V = VACTIVE FIELD = FIELD	HREF = $\overline{\text{HRESET}}$ VREF = $\overline{\text{VRESET}}$	RD	DVALID	HFF
1	1	Not used	-	-	-	-	-

Table xx. Output Mode Selection

EXTENDED OUTPUT CONTROL (SUBADDRESS 04H)

RANGE DATA RANGE SELECTION (D0)

The RANGE bit control the Luminance and Chrominance data ranges and activates a limiter. Table xx shows thye two available ranges which can be used for the ADV7185.

RANGE	Function
0	Luminance Data range is code 16 - 235 Chrominance Data range is code 16 - 240
1	Luminance Data range is code 1 - 254 Chrominance Data range is code 1 - 254

Table xx. Data Range Selection

GENERAL PURPOSE OUTPUT (SUBADDRESS 05H)

GPEH GENERAL PURPOSE ENABLE HIGH (D5)

The GPEH is used to control the output drivers on the GPO[3 : 2], table xx shows the bit assignment.

GPEH	Function
0	GP[3 : 2] outputs tri-state
1	GP[3 : 2] outputs enabled

Table xx. General Purpose Enable high

GPEL GENERAL PURPOSE ENABLE LOW (D4)

The GPEL is used to control the output drivers on the GPO[1 : 0], table xx shows the bit assignment.

GPEL	Function
0	GP[1 : 0] outputs tri-state
1	GP[1 : 0] outputs enabled

Table xx. General Purpose Enable low

GPO[3 : 0] GENERAL PURPOSE OUTPUT (D3-D0)

The GPO[3 : 0]bits are used to control the GPO[3 : 0] output pins, table xx shows the bit assignments. A logic high or low can be driven on each of the four general purpose outputs.

GPO3	GPO2	GPO1	GPO0	Function
0	0	0	0	GPO[3 : 0] drivers output logic 0
-	-	-	-	
1	1	1	1	GPO[3 : 0] drivers output logic 1

Table xx. General Purpose Enable low

FIFO CONTROL (SUBADDRESS 07H)

FFST FIFO FLAG SELF TIME (D7)

This FFST bit selects whether the FIFO flags AEF, AFF and HFF are output synchronous to the clock provided by the user via CLKIN pin or whether they are sel-timed using the internal 27MHz system clock within the ADV7185. If timed from the CLKIN pin then the FIFO flags will change synchronously with the rising edge of the clock. This however means that the user must provide a continuously running clock to the ADV7185 otherwise the flags will never change state. In the self-timed mode the flags are clocked from the internal 27MHz clock and are thus toggling if the user does not provide a continuous clock. This could be used to interrupt a statemachine or CPU which will handle reading the data from the FIFO.

FFST	Function
0	FIFO Flags are timed of CLKIN (not self-timed)
1	FIFO Flags are timed of 27MHz (self-timed)

Table xx. FIFO Flag Self Time

AFR AUTOMATIC FIFO RESET (D6)

The AFR bit controls a function by which the FIFO is automatically reset at the end of a field of video. Any remaining pixel data in the FIFO will be cleared so that it is empty at the start of the next field. Table xx shows the polarity assignment of this bit. Please note that this bit is not active in OM_SEL[1 : 0] is configured for Line Locked Clock Interface (OM_SEL[1 : 0] = 0,0).

AFR	Function
0	No automatic reset of the output FIFO
1	FIFO automatically reset at end of every field

Table xx. Automatic FIFO Reset

FR FIFO RESET (D5)

If the FR bit is set to 1 this will cause the FIFO to reset. After the reset is executed this bit will be cleared itself. The FIFO reset is executed immediately, a reset to the FIFO means that all read pointers are set to location zero. Note this bit is not active in OM_SEL[1 : 0] is configured for Line Locked Clock Interface (OM_SEL[1 : 0] = 0,0).

FR	Function
0	Normal FIFO operation
1	Reset FIFO output immediately, this bit is cleared automatically after the reset is applied. The reset FIFO resets the internal pointer to start location

Table xx. FIFO Reset

FFM[4 : 0] FIFO FLAG MARGIN (D4-D0)

The FFM[2 : 0] bits are used to program at which physical location within the FIFO the FIFO flags AEF and AFF become active. The margin is symmetrical for both the empty and full flag. Table xx shows the range of programmability for these flags. Example: with the FIFO total size of 256 and FFM[4 : 0]= 5'd23, the AEF will signal that less or equal to 23 locations within the FIFO are filled. The AFF will become active when 256-23 = 233 locations within the FIFO are filled.

FFM[4 : 0]	Function
0	Forbidden value, latency in generating FIFO flags(AFF/AEF) will result in FIFO overflowing before user has time to empty the FIFO
8	FIFO Flags AFF/AEF are generated when the FIFO is 8 words from being full. This is the minimum allowable FIFO Flag Margin, user will have time to empty FIFO as FLAG is generated a few clock cycles before FIFO is full/empty
32	FIFO Flags AFF/AEF are generated when the FIFO is 32words from being full.

Table xx. FIFO Flag Margin

CONTRAST CONTROL (SUBADDRESS 08H)

CON[7 : 0] CONTRAST CONTROL (D7-D0)

The CON[7 : 0]bits are used to control the contrast of the video signal, Table xx shows the range of control.

CON[7 : 0]	GAIN
0	0 (Luminance off)
128	1 (Luminance gain = 1)
255	1.992 (maximum Luminance gain)

Table xx. Contrast Control

SATURATION CONTROL (SUBADDRESS 09H)

SAT[7 : 0] SATURATION CONTROL (D7-D0)

The SAT[7 : 0]bits are used to control the saturation of the video signal, Table xx shows the range of control.

SAT[7 :0]	GAIN
0	0 (color off)
128	1 (color gain =1)
255	1.992 (maximum color gain)

Table xx. Saturation Control

BRIGHTNESS CONTROL (SUBADDRESS 0AH)

BRI[7 : 0] BRIGHTNESS CONTROL (D7-D0)

The BRI[7 : 0]bits are used to control brightness of the video signal, Table xx shows the range of control.

BRI[7 : 0]	OFFSET
0	0 (no brightness added)
1	8
127	1016 (mamimum brightness setting)
128	-1024
255	-8 (maximum darkness setting)

Table xx. Brightness Control

HUE CONTROL (SUBADDRESS 0BH)

HUE[7 : 0] HUE CONTROL (D7-D0)

The HUE[7 : 0]bits are used to control brightness of the video signal, Table xx shows the range of control.

HUE{7 : 0}	HUE PHASE (DEG)
0	0.0°
1	+0.7°
2	+1.4°
...	...
127	+89.3°
128	-90.0°
129	-89.3°
...	...
255	-0.7°

Table xx. Hue Control

DEFAULT VALUE Y (SUBADDRESS 0CH)

DEF_Y[5 : 0] DEFAULT VALUE Y (D7-D2)

The DEF_Y[5 : 0]bits are used output a default Y or Luminance value on the pixel output port (P0-P19). This Y value can be forced onto to output (using DEF_VAL_EN) or output when cropping is selected or when lock of the video source is lost.

DEF_Y[5 : 0]	Function
6 bit value	Default Y value 8 bit mode Y[7:0] = {DEF_Y[5:0],0,0} , range 0 - 252 10bit mode Y[9:0] = {DEF_Y[5:0],0,0,0,0}, range 0 - 1008

Table xx. Defauly Value Y

DEF_VAL_AUTO_EN DEFAULT VALUE AUTOMATIC ENABLE (D1)

The DEF_VAL_AUTO_EN bits is used to enable the DEF_Y & DEF_C values to be used when Lock is lost or when Cropping is enabled.

DEF_VAL_AUTO_EN	Function
0	Don't use default Y, Cr and Cb values if Cropping or if Lock is lost
1	Use default Y, Cr and Cb values if Cropping or if Lock is lost

Table xx. Defauly Value Automatic Enable

DEF_VAL_EN DEFAULT VALUE ENABLE (D0)

The DEF_VAL_EN bits is used to force the DEF_Y & DEF_C values to be used in all cases.

DEF_VAL_EN	Function
0	Don't force the use of default Y, Cr and Cb values
1	Always use default Y, Cr and Cb values

Table xx. Defauly Value C

DEFAULT VALUE C (SUBADDRESS 0DH)

DEF_C[7 : 0] DEFAULT VALUE C (D7-D0)

The DEF_C[7 : 0]bits are used output a default C or Chrominance value on the pixel output port (P0-P19). This C value (Cb & Cr) can be forced onto to output (using DEF_VAL_EN) or output when cropping is selected or when lock of the video source is lost.

DEF_C[7 : 0]	Function
8 bit value	Default Cb & Cr values 8 bit mode Cr[7:0] = {DEF_C[7 : 4],0,0,0,0} , range 0 - 240 10bit mode Cr[9:0] = {DEF_C[7 : 4],0,0,0,0,0,0} , range 0 - 960 8 bit mode Cb[7:0] = {DEF_C[3 : 0],0,0,0,0} , range 0 - 240 10bit mode Cb[9:0] = {DEF_C[3 : 0],0,0,0,0,0,0} , range 0 - 960

Table xx. Defauly Value C

TEMPORAL DECIMATION (SUBADDRESS 0EH)

TDR[3 : 0]TEMPORAL DECIMATION RATE (D6-D3)

The TDR[3 : 0]bits control how many fields/frames (as specified in the TDC[1 : 0] register) are to be skipped before a valid one is output.

TDR3	TDR2	TDR1	TDR	Function
0	0	0	0	Skip no field/frame between valid output
0	0	0	1	Skip 1 field/frame between valid output
...	Skip field/frame between valid output
1	1	1	1	Skip no field/frame between valid output

Table xx. Temporal Decimation Rate

TDC[1 : 0]TEMPORAL DECIMATION CONTROL (D2-D1)

The TDC[1 : 0]bits control the suppression of selected fields of video as shown in Table xx.

TDC1	TDC0	Function
0	0	Suppress frames, start with even field
0	1	Suppress frames, start with odd field
1	0	Suppress even fields only
1	1	Suppress odd fields only

Table xx. Temporal Decimation Control

POWER MANAGEMENT (SUBADDRESS 0FH)

RES RESET CONTROL (D7)

The RES bit when set will generate a Reset. The $\overline{\text{RESET}}$ will be pulled to a logic low and then go high again after a short period of time. All I²C registers will be reset to their default values. After a reset sequence the ADV7185 starts to acquire the incoming video signal.

RES	Function
0	Normal operation
1	Start Reset sequence, all register will be reset to their default values and the $\overline{\text{RESET}}$ pin will be pulled low for a short duration.

Table xx. Reset Control

TRAQ TIMING RE-ACQUIRE (D6)

The TRAQ bit when set will result in the ADV7185 re-acquiring the video signal and is a software version of the ISO pin function. Setting this bit will result in a shorter time that it takes the ADV7185 to acquire a new video signal since the decoder does not have to first determine that lost was locked. Once set this bit will be automatically cleared. The function of this bit is equivalent to a rest of the ADV7185 without re-initialising the I2C registers again. The RESET is unaffected by this control bit.

TRAQ	Function
0	Normal operation
1	Start re-acquire of video signal immediately

Table xx. Timing Re-acquire

PWRDN POWER DOWN CONTROL (D5)

The PWRDN bit when set puts the ADV7185 in a shut down mode whereby only a very small current is consumed by the decoder.

PWRDN	Function
0	Normal operation
1	Power down part in ultra low current mode

Table xx. Power Down control

PS_CG POWER SAVE LLC CLOCK GENERATOR (D4)

The PS_CG bit when set puts the ADV7185 LLC Clock generator in power down mode and as a result the clock output is switched off.

PS_CG	Function
0	LLC Clock generator in normal operation
1	LLC Clock generator in power save mode

Table xx. Power Save LLC Clock Generator

PS_REF POWER SAVE REFERENCE (D3)

The PS_REF bit when set puts the ADV7185 internal voltage reference in power down mode.

PS_REF	Function
0	Analog voltage reference normal operation
1	Analog voltage reference power save mode

Table xx. Power Save Reference

PDBP POWER DOWN BIT PRIORITY (D2)

The PDBP bit sets whether the PWRDN pin or the I2C PWRDN(D5) bit has highest priority to put the ADV7185 in Power down mode.

PDBP	Function
0	$\overline{\text{PWRDN}}$ pin has highest priority.
1	PWRDN I ² C bit has highest priority.

Table xx. Power down bit priority

PSC [1 : 0] POWER SAVE CONTROL (D1-D0)

The PSC[1 : 0] bits allow for a variety of power save modes to be selected, see Table xx for more details.

PSC1	PSC0	Function
0	0	Normal operation
0	1	Enable Power Saving mode for CVBS input only
1	0	Enable power down of digital core section and leave analog front end powered on
1	1	Enable Power Save mode which enables faster power on than PWRDN but consumes more current than the PWRDN state

Table xx. Power Save Control

STATUS REGISTER (SUBADDRESS 10H)

STATUS[7 : 0] STATUS REGISTER (D7-D0)

This STATUS [7 : 0] is a read only register. Table xx list the status bits which can be read back from this register to help the user use the part more effectively.

STATUS [7 : 0]	STATE	Function (Read only register)
STATUS[0]	1	Horizontal locked right now
STATUS[0]	0	Lost Horizontal Lock
STATUS[1]	1	Lost lock since last read of Status register
STATUS[1]	0	No lock lost since last read of Status register
STATUS[2]	1	Fsc locked right now
STATUS[2]	0	Fsc not locked
STATUS[3]	1	50Hz field rate auto detected
STATUS[3]	0	60Hz filed rate auto detected
STATUS[4]	1	ADC underflow detected
STATUS[4]	0	No ADC underflow detected
STATUS[5]	1	ADC overflow detected
STATUS[5]	0	No ADC overflow detected
STATUS[6]	1	White Peak Mode now active
STATUS[6]	0	White Paek mode is not active
STATUS[7]	1	Reserved
STATUS[7]	0	Reserved

Table xx. Status Register

INFO REGISTER (SUBADDRESS 11H)

IDENT[2 : 0] INFO REGISTER (D2-D0)

This IDENT[3 : 0] is a read only register. This register contains the revision code for the silicon.

IDENT [2 : 0]	Function (Read only register)
000	Revision 1.0 Code
.....	Reserved
111	Reserved

Table xx. Info Register

ADVANCED USER REGISTER MAP

ANALOG CLAMP CONTROL (SUBADDRESS 14H)**VCLEN VOLTAGE CLAMP ENABLE (D5)**

The VCLEN bit allows the user to turn on and off the voltage clamp circuit in the ADV7185 front end.

VCLEN	Function
0	Voltage Clamp disabled
1	Voltage Clamp enabled

Table xx. Voltage Clamp enable

CCLEN CURRENT CLAMP ENABLE (D4)

The CCLEN bit allows the user to turn on and off the current clamp circuit in the ADV7185 front end.

CCLEN	Function
0	Current Clamp disabled
1	Current Clamp enabled

Table xx. Current Clamp enable

FACL[1 : 0] FAST CLAMP LENGHT (D3-D2)

The FACL[1 : 0] bits allows the user to select the number of clock cycles the fast current clamp is switched on for on each video line. Table xx shows the possible ranges which can be selected.

FACL 1	FACL 0	Function
0	0	Current source switched on for 16 clock cycles
0	1	Current source switched on for 32 clock cycles
1	0	Current source switched on for 64 clock cycles
1	1	Current source switched on for 128 clock cycles

Table xx. Fast Clamp Lenght

FICL[1 : 0] FINE CLAMP LENGHT (D1-D0)

The FICL[1 : 0] bits allows the user to select the number of clock cycles the fine current clamp is switched on for on each video line. Table xx shows the possible ranges which can be selected.

FICL 1	FICL 0	Function
0	0	Current source switched on for 16 clock cycles
0	1	Current source switched on for 32 clock cycles
1	0	Current source switched on for 64 clock cycles
1	1	Current source switched on for 128 clock cycles

Table xx. Fine Clamp Lenght

DIGITAL CLAMP CONTROL (SUBADDRESS 15H)

DCCM DIGITAL COLOUR CLAMP MODE (D7)

The DCCM bit allows the user to select automatic digital clamp or manual clamp mode whereby the user can set a desired clamp offset value.

DCCM	Function
0	Automatic Digital Clamp enabled
1	Manual offset correction via DCCO[11 : 0] for C only

Table xx. Digital Colour Clamp mode

DCT [1 : 0] DIGITAL CLAMP TIMING (D6-D5)

The DCT[1 : 0] bits allows the user to select the desired time constant for the digital clamping circuit in the ADV7185.

DCT 1	DCT 0	Function
0	0	Slow clamp timing (time constant = 1sec)
0	1	Medium clamp timing (time constant = 0.5sec)
1	0	Fast clamp timing (time constant = 0.1sec)
1	1	Dependent on VID_QUAL selected

Table xx. Digital Clamp Timing

DCFE DIGITAL CLAMP FREEZE ENABLE(D4)

This register bit allows to freeze the digital clamp loop at any point in time. It is intended mainly for users who would like to do their own clamping. They should disable the current sources for analog clamping via the appropriate register bits and then freeze the digital clamp loop after letting it settle via the DCFE bit. This bit affects the digital clamp loops in both Y and C path.

DCFE	Function
0	Digital Clamp loop operational
1	Digital Clamp loop frozen

Table xx. Digital Clamp Freeze Enable

DIGITAL COLOR CLAMP OFFSET (SUBADDRESS 15H)

DCCO [11 : 8] DIGITAL COLOUR CLAMP OFFSET (D3-D0)

DIGITAL COLOR CLAMP OFFSET (SUBADDRESS 16H)

DCCO[7 : 0] DIGITAL COLOUR CLAMP OFFSET (D7-D0)

The DCCO[11 : 0] bits allow the user the ADV7185 in manual offset mode. The value load here is the digital offset which is added to the output of the ADC.

DCCO[11 : 0]	Function
0....4095	Manual digital clamp offset value added to ADC output

Table xx. Digital Colour Clamp Offset

SHAPING FILTER CONTROL (SUBADDRESS 17H)

CSFM[3 : 0] CHROMA SHAPING FILTERS (D7-D5)

The CSFM[3 : 0] bits allow the user to select from a range of low pass filters for the chrominance signal, see Table xx for modes. When switched in automatic mode, then the filter is selected based on the scaling factor as selected by the user.

CSFM 2	CSFM 1	CSFM 0	Filter Responses
0	0	0	Auto selection 1.5Mhz
0	0	1	Auto selection 2.17Mhz
0	1	0	SH1
0	1	1	SH2
1	0	0	SH3
1	0	1	SH4
1	1	0	SH5
1	1	1	reserved

Table xx. Digital Colour Clamp Offset

PRELIMINARY
TECHNICAL
DATA

YSFM[4 : 0] LUMA SHAPING FILTERS (D4-D0)

The YSFM[4 : 0] bits allow the user to select from a range of low pass and notch filters for the luminance signal, see Table xx for modes. When switched in automatic mode, then the filter is selected based on the video standard and the scaling factor as selected by the user.

YSFM 4	YSFM 3	YSFM 2	YSFM 1	YSFM 0	Filter Responses
0	0	0	0	0	Auto selection Wide Notch
0	0	0	0	1	Auto selection Narrow Notch
0	0	0	1	0	SVHS1
0	0	0	1	1	SVHS2
0	0	1	0	0	SVHS3
0	0	1	0	1	SVHS4
0	0	1	1	0	SVHS5
0	0	1	1	1	SVHS6
0	1	0	0	0	SVHS7
0	1	0	0	1	SVHS8
0	1	0	1	0	SVHS9
0	1	0	1	1	SVHS10
0	1	1	0	0	SVHS11
0	1	1	0	1	SVHS12
0	1	1	1	0	SVHS13
0	1	1	1	1	SVHS14
1	0	0	0	0	SVHS15
1	0	0	0	1	SVHS16
1	0	0	1	0	SVHS17
1	0	0	1	1	PAL NN 1
1	0	1	0	0	PAL NN 2
1	0	1	0	1	PAL NN 3
1	0	1	1	0	PAL WN 1
1	0	1	1	1	PAL WN 2
1	1	0	0	0	NTSC NN 1
1	1	0	0	1	NTSC NN 2
1	1	0	1	0	NTSC NN 3
1	1	0	1	1	NTSC WN 1
1	1	1	0	0	NTSC WN 2
1	1	1	0	1	NTSC WN 3
1	1	1	1	0	not used
1	1	1	1	1	not used

Table xx. Luma Shaping Filters

COMB FILTER CONTROL (SUBADDRESS 19H)

CCMB_AD CHROMA COMB ADAPTIVE(D4)

The CCMB_AD bit controls the comb filter logic. If set to logic high the comb filters are configured in an adaptive mode which allows for comb filter to change modes.

CCMB_AD	Function
0	Chroma Comb filter configure for non-adaptive mode
1	Chroma Comb filter configure for adaptive mode

Table xx. Digital Colour Clamp Offset

CCM[1 : 0] CHROMA COMB MODE(D3-D2)

The CCM[1 : 0] bits controls the chroma comb filter mode selected, see Table xx for available modes.

CCM 1	CCM 0	Function
0	0	No comb selected
0	1	1H Comb enabled
1	0	2H Comb enabled
1	1	reserved

Table xx. Chroma Comb mode

LCM[1 : 0] LUMA COMB MODE(D1-D0)

The LCM[1 : 0] bits controls the luma comb filter mode selected, see Table xx for available modes.

LCM 1	LCM 0	Function
0	0	No comb selected
0	1	1H Comb enabled
1	0	2H Comb enabled
1	1	Automatic selection of highest comb

Table xx. Luma Comb mode

SCALING/CROPPING MSB (SUBADDRESS 1AH)

SCE SCALING ENABLE (D0)

The SCE bits allow the user to enable and disable horizontal and vertical scaling on the ADV7185. Note when scaling/cropping is enable these registers must be loaded with a specific valid value as their value will be undetermined unless the register has been written to.

SCE	Function
0	Scaling disabled
1	Scaling enabled

Table xx. Scaling Enable

ACTIVE VIDEO DESIRED LINES (SUBADDRESS 1BH)

AVDL[7: 0] ACTIVE VIDEO DESIRED LINES (D7-DO)

SCALING/CROPPING MSB (SUBADDRESS 1AH)

AVDL [8] ACTIVE VIDEO DESIRED LINES (D7)

The AVDL[8 : 0] bits allow the user to select the number of active video lines that are output. This register must be programmed for scaling/cropping to work properly, Table xx shows the valid range which can be programmed. Note when scaling/cropping is enable these registers must be loaded with a specific valid value as their value will be undetermined unless the register has been written to.

AVDL[8 : 0]	Function
0	Number of active video lines = 0 lines
240	CCIR number of active lines for NTSC
287	CCIR number of active lines for PAL
241....512	Forbidden values in this range in NTSC
289....512	Forbidden values in this range in PAL

Table xx. Active Video Desired Lines

ACTIVE VIDEO VERTICAL BEGIN (SUBADDRESS 1CH)

AVVB[7: 0] ACTIVE VIDEO VERTICAL BEGIN (D7-DO)

SCALING/CROPPING MSB (SUBADDRESS 1AH)

AVVB [8] ACTIVE VIDEO VERTICAL BEGIN (D6)

The AVVB[8 : 0] bits allow the user to select which line the first active video line is output on. This register must be programmed for scaling/cropping to work properly, Table xx shows the valid range which can be programmed. Note when scaling/cropping is enable these registers must be loaded with a specific valid value as their value will be undetermined unless the register has been written to.

AVVB[8 : 0]	Function
0...21	Forbidden values
22-262	Valid range for NTSC active video begin value
23-310	Valid range for PAL active video begin value
311....512	Forbidden values

Table xx. Active Video Vertical Begin

VERTICAL SCLE VALUE 1 (SUBADDRESS 1DH)

VSCV[10 : 8] VERTICAL SCALE VALUE (D2-D0)

VERTICAL SCLE VALUE 2 (SUBADDRESS 1EH)

VSCV[7 : 0] VERTICAL SCALE VALUE (D7-D0)

The VSCV[10 : 0] bits allow the user to control the vertical scaling factor, the formula used for scaling can be viewed earlier in this document. Table xx shows the valid range for scaling. Note when scaling/cropping is enable these registers must be loaded with a specific valid value as their value will be undetermined unless the register has been written to.

VSCV[10 : 0]	Function
0...255	Scaling range for a scaling factor below 1
256	Default Vertical scaling value, a scaling factor of 1
257...2047	Forbidden values in this range

Table xx. Vertical Scaling Value

ACTIVE VIDEO HORIZONTAL BEGIN (SUBADDRESS 1FH)

AVVB[8 : 1] ACTIVE VIDEO HORIZONTAL BEGIN (D7-D0)

SCALING/CROPPING MSB (SUBADDRESS 1AH)

AVVB[9] ACTIVE VIDEO HORIZONTAL BEGIN (D5)

The AVVB[9 : 1] bits allow the user to select the number of the first video sample pixel to be output by the ADV7185. Note that this position control is in minimum increments off 1 pixel (2 clock cycles). Also it should be noted that when scaling/cropping is enable these registers must be loaded with a specific valid value as their value will be undetermined unless the register has been written to.

AVHB[9 : 1]	Function
0	First pixel output after falling edge of Hsync
61	CCIR value for first active video pixel for NTSC
66	CCIR value for first active video pixel for PAL
511	Maximum value for first video pixel

Table xx. Active Video Horizontal begin

ACTIVE VIDEO DESIRED PIXEL (SUBADDRESS 20H)

AVDP[7 : 0] ACTIVE VIDEO DESIRED PIXEL (D7-D0)

SCALING/CROPPING MSB (SUBADDRESS 1AH)

AVVB[9 : 8] ACTIVE VIDEO DESIRED PIXEL (D4-D3)

The AVDP[9 : 0] bits allow the user when cropping/scaling to specify the total number of video samples which is output by the ADV7185. Note when scaling/cropping is enable these registers must be loaded with a specific valid value as their value will be undetermined unless the register has been written to.

AVDP[9 : 0]	Function
0	no pixels output
720	Mamimum number of pixels allowed (720 pixels on a line)
721..1023	Forbidden range for this control

Table xx. Active Video Desired Pixel

HORIZONTAL SCALE VALUE 1 (SUBADDRESS 21H)

HSCV[15 : 8] ACTIVE VIDEO DESIRED PIXEL (D7-D0)

HORIZONTAL SCALE VALUE 2 (SUBADDRESS 22H)

HSCV[7 : 0] ACTIVE VIDEO DESIRED PIXEL (D7-D0)

The HSCV[15 : 0] bits allow the user to select the horizontal scaling factor, the formula used for scaling can be viewed earlier in this document. Note when scaling/cropping is enable these registers must be loaded with a specific valid value as their value will be undetermined unless the register has been written to.

HSCV[15 : 0]	Function
0	No video pixel output
2427	Default value for a scaling factor 1for PAL
2444	Default value for a scaling factor 1for NTSC
2445...65,535	forbidden values in this range

Table xx. Horizontal Scaling Value

COLOR SUBCARRIER CONTROL 1 (SUBADDRESS 24H)

CSM COLOR SUBCARRIER MANUAL (D4)

The CSM bit allow the user to override any subcarrier frequency pre-selected by the video input bits. It works in conjunction with the CSMF[27 : 0] register.

CSM	Function
0	Manual Fsc selection disabled
1	Use Fsc as specified in CSMF[27: 0], manual Fsc enabled

Table xx. Color Subcarrier Manual Enable

COLOR SUBCARRIER CONTROL 1 (SUBADDRESS 24H)

CSMF[27 : 24] COLOR SUBCARRIER MANUAL FREQUENCY(D3-D0)

COLOR SUBCARRIER CONTROL 2 (SUBADDRESS 25H)

CSMF[23 : 16] COLOR SUBCARRIER MANUAL FREQUENCY(D7-D0)

COLOR SUBCARRIER CONTROL 3 (SUBADDRESS 26H)

CSMF[15 : 8] COLOR SUBCARRIER MANUAL FREQUENCY(D7-D0)

COLOR SUBCARRIER CONTROL 4 (SUBADDRESS 27H)

CSMF[7 : 0] COLOR SUBCARRIER MANUAL FREQUENCY(D7-D0)

The CSMF[27 : 0] bits allow the user to programme a desired subcarrier frequency when the CSM bit is enabled. The CSMF[27 : 0] control the internal DDS to generate the user defined frequency. The formula for calculating the subcarrier frequency is shown earlier in this document.

CSMF[27 : 0]	Function
0...2000	Forbidden range for subcarrier frequency
35,588,034	Default NTSC value for a subcarrier of 3.579545MHz
44,079,277	Default PAL B/D/G/H/I value for a subcarrier of 4.43361875MHz
35,548,922	Default PAL M value for a subcarrier of 3.57561149MHz
35,612,996	Default PAL Combinational N value for a subcarrier of 3.58205625MHz

Table xx. Color Subcarrier Manual Frequency

PIXEL DELAY CONTROL (SUBADDRESS 28H)

SWPC SWAP PIXEL CB/CR(D7)

The SWPC bit allow the user to swap the Cb and Cr samples on the video output port. This is useful for timing alignment.

SWPC	Function
0	No swapping of Cr and Cb values
1	Swap Cr and Cb values

Table xx. Swap Pixel Cb/Cr

CTA[2 : 0] CHROMA TIMING ADJUST (D5-D3)

The CTA[2 : 0] bits allow the user to adjust the timing differences between the chroma and the luma samples. The range for chroma to luma delay varies from +2 pixels to -3pixels.

CTA 2	CTA 1	CTA 0	Function
0	0	0	reserved
0	0	1	Chrominance delayed by 2 pixels with respect to Luminance
0	1	0	Chrominance delayed by 1 pixels with respect to Luminance
0	1	1	No delay on Chrominance or Luminance channels
1	0	0	Luminance delayed by 1 pixels with respect to Chrominance
1	0	1	Luminance delayed by 2 pixels with respect to Chrominance
1	1	0	Luminance delayed by 3 pixels with respect to Chrominance
1	1	1	reserved

Table xx. Chroma Timing Adjust

MANUAL CLOCK CONTROL 1 (SUBADDRESS 29H)

FIX27E FIXED FREQUENCY 27MHz ENABLE(D7)

The FIX27E bit allows the user to output the 27MHz crystal clock output via LLC1, LLC2 and LLCREF output pins. This feature is intended for usage during free run mode.

FIX27E	Function
0	Output clock signals (LLC1 & LLC2) at a frequency determined by the clock generator (line locked) on board
1	Output a 27MHz fixed clock driven by the crystal source

Table xx. Fixed Frequency 27MHz Enable

CLKMANE CLOCK GENERATOR MANUAL ENABLE (D6)

The CLKMANE bit configures the analog clock generator to produce a fixed clock frequency which is not dependent on the input video source. Output is achieved via LLC1, LLC2 and LLCREF output pins. Intended for usage during CAPI and SCAP1 modes of operation.

CLKMANE	Function
0	Clock output frequency determine by video source (LLC1)
1	Clock output frequency determined by value loaded into CLKVAL[13 : 0]

Table xx. Clock Generator Manual Enable

MANUAL CLOCK CONTROL 1 (SUBADDRESS 29H)

CLKVAL[13 : 8] FIXED FREQUENCY VALUE (D5-D0)

MANUAL CLOCK CONTROL 2 (SUBADDRESS 2AH)

CSMF[23 : 16] FIXED FREQUENCY VALUE (D7-D0)

The CLKVAL[13 : 0] bits allow the user to programme a desired output frequency on the LLC1, LLC2 and LLCREF pins. Tablexx shows the possible programming range for this output clock. A formula for calculating this frequency is shown earlier in this document.

CLKVAL [13 : 0]	Function
0	Minimum output frequency of LLC1 (2.7KHz)
8826	Output clock frequency of 24.54MHz for NTSC Square Pixel mode
9709	Output clock frequency of 27MHz for PAL/NTSC mode
10608	Output clock frequency of 29.5MHz for PAL Square Pixel mode
16384	Maximum output frequency of LLC1 (45.5625MHz)

Table xx. Fixed Frequency Value

AGC MODE CONTROL (SUBADDRESS 2CH)

LAGC[2 : 0] LUMA AUTOMATIC GAIN CONTROL (D6-D4)

The LAGC[2 : 0] bits control the mode of operation of the Luma Automatic Gain Control block. Table xx shows the possible modes of operation.

LAGC 2	LAGC 1	LAGC 0	Function
0	0	0	Manual fixed gain (use LMG[11 : 0])
0	0	1	AGC (blank level to sync tip) manual maxIRE control no override through white peak
0	1	0	AGC (blank level to sync tip) manual maxIRE control automatic override through white peak
0	1	1	AGC (blank level to sync tip) automatic maxIRE control no override through white peak
1	0	0	AGC (blank level to sync tip) automatic maxIRE control automatic override through white peak
1	0	1	AGC (active video with white peak)
1	1	0	AGC (active video with average video)
1	1	1	Freeze gain

Table xx. Luma Automatic Gain Control

CAGC[2 : 0] CHROMA AUTOMATIC GAIN CONTROL (D1-D0)

The cAGC[1 : 0] bits control the mode of operation of the Chroma Automatic Gain Control block. Table xx shows the possible modes of operation.

CAGC 1	CAGC 0	Function
0	0	Manual fixed gain use CMG[11 : 0]
0	1	Luminance gain used for Chrominance
1	0	Automatic Gain (based on colour burst)
1	1	Freeze Chrominance gain

Table xx. Chroma Automatic Gain Control

CHROMA GAIN CONTROL 1 (SUBADDRESS 2DH)

CAGT[1 : 0] CHROMA AUTOMATIC GAIN TIMING (D7-D6)

The CAGT[1 : 0] bits control the tracking speed of the Chroma AGC. Note these bits will only have effect if the CAGC[1:0] bits are set to 10(automatic gain).

CAGT 1	CAGT 0	Function
0	0	Chroma AGC Slow
0	1	Chroma AGC Medium
1	0	Chroma AGC Fast
1	1	Chroma AGC dependent on VID_QUAL setting

Table xx. Chroma Automatic Gain Control Timing

CHROMA GAIN CONTROL 1 (SUBADDRESS 2DH)

CMG[11 : 8] CHROMA GAIN (D3-D0)

CHROMA GAIN CONTROL 2 (SUBADDRESS 2EH)

CMG[7 : 0] CHROMA GAIN (D7-D0)

The CMG[11 : 0] bits act as a dual function register. If written to, a desired gain can be programmed for the chroma channel. This gain will become active if the CAGC{1 : 0} mode is switched to Manual fixed gain. If read from this register will return the currently actually used gain value for the chroma channel. Depending on the settings of the CAGC[1 : 0] bits this will be either one of the following, 1) Chroma manual gain (CAGC[1 : 0] set to chroma manual gain mode, 2)Chroma automatic gain value (CAGC[1 : 0] set to any of the other automatic modes).

	Mode	Function
GMG[11 : 0] = X	write	Manual gain for chrominance channel
CG[11 : 0]	read	actually used gain (same as write value if in manual gain mode or automatic gain value if in automatic gain mode)

Table xx. Chroma Gain

LUMA GAIN CONTROL 1 (SUBADDRESS 2FH)

LAGT[1 : 0] LUMA AUTOMATIC GAIN TIMING (D7-D6)

The LAGT[1 : 0] bits control the tracking speed of the Luma AGC. Note these bits will only have effect if the LAGC[2:0] bits are set to 001,010,011 or 100 (automatic gain control modes).

LAGT 1	LAGT 0	Function
0	0	Luma AGC Slow
0	1	Luma AGC Medium
1	0	Luma AGC Fast
1	1	Luma AGC dependent on VID_QUAL setting

Table xx. Luma Automatic Gain Timing

LUMA GAIN CONTROL 1 (SUBADDRESS 2FH)

LMG[11 : 8] CHROMA GAIN (D3-D0)

LUMA GAIN CONTROL 2 (SUBADDRESS 30H)

LMG[7 : 0] LUMA GAIN (D7-D0)

The LMG[11 : 0] bits act as a dual function register. If written to, a desired gain can be programmed for the chroma channel. This gain will become active if the LAGC[1 : 0] mode is switched to Manual fixed gain. If read from this register will return the currently actually used gain value for the luma channel. Depending on the settings of the LAGC[1 : 0] bits this will be either one of the following, 1) Luma manual gain (LAGC[1 : 0] set to luma manual gain mode, 2)Luma automatic gain value (LAGC[1 : 0] set to any of the other automatic modes).

LG[11 : 0]	Mode	Function
LMG[11 : 0]	write	Manual gain for luminance channel
LG[11 : 0]	read	actually used gain (same as write value if in manual gain mode or automatic gain value if in automatic gain mode)

Table xx. Luma Gain

MANUAL GAIN SHADOW CONTROL1 (SUBADDRESS 31H)

SGUE SURVEILLANCE GAIN UPDATE ENABLE(D7)

The SGUE when set enables an advanced feature for the surveillance mode of operation. Please refer to LMGS[11 : 0] for further details.

SGUE	Function
0	Disable use of LMGS update facility
1	Use LMGS update facility

Table xx. Surveillance Gain Update Enable

MANUAL GAIN SHADOW CONTROL 1 (SUBADDRESS 31H)

LMGS[11 : 8] LUMA GAIN STORE (D3-D0)

MANUAL GAIN SHADOW CONTROL 2 (SUBADDRESS 32H)

LMGS[7 : 0] LUMA GAIN STORE (D7-D0)

The LMGS[11 : 0] is a register store which allows the user in the surveillance mode to pre-program a gain into it. This gain value is simply stored and will be copied into the LMG[11 : 0] register only after the ISO pin has been toggled, the INSEL register has been changed or the TRAQ bit has been set. The register allows for the gain calibration of each channel. This function is not replicated in the chroma path, however it is suggested to adapt the chroma gain from the luma path by setting CAGC[1 : 0] = 01.

LMGS[11 : 0]	Function
0...4095	Gain for next input source which is switched (surveillance mode only)

Table xx. Luma Manual Gain Store

MISC GAIN CONTROL (SUBADDRESS 33H)

CKE COLOR KILL ENABLE (D6)

The CKE bit is used to control the optional color kill function to be switched on or off. If color kill is enabled, color processing will be switched off (only luma output) if the color burst of the incoming video signal is less than 22% of its nominal amplitude for 128 consecutive video lines. To switch the color processing back on, another 128 consecutive lines with a color burst greater than 22% of its nominal amplitude is required.

CKE	Function
0	Colour Kill function disabled
1	Colour Kill function enabled

Table xx. Color Kill Enable

MIRE[2 : 0] MAX IRE(D4-D2)

The MIRE[2 : 0] bits are used to select the maximum input IRE level which is dependent on the video standard selected. Table xx shows the possible ranges to select from.

MIRE [2 : 0]	Function	
	PAL (IRE)	NTSC (IRE)
0 0 0	133	122
0 0 1	125	115
0 1 0	120	110
0 1 1	115	105
1 0 0	110	100
1 0 1	105	100
1 1 0	100	100
1 1 1	100	100

Table xx. Max IRE

AV_AL AVERAGE BRIGHTNESS ACTIVE LINES(D1)

The gain can be determined based on the average brightness of the active video by using the average video mode in the LAGC[2 : 0] register. the AV_AL bit allows to select between two ranges of active video lines to determine the average brightness. Note that this bit can only be set to a logic high when the input signal conforms to the PAL 625 standard.

AV_AL	Function
0	Use lines 33 -310 to determine average active video brightness
1	Use lines 33 -270 to determine average active video brightness

Table xx. Average Video Active Lines

PW_UPD PEAK WHITE UPDATE (D0)

The peak white and average video algorithms determine the gain based on measurements taken from the active video. PW_UPD bit determines the rate of gain change. Note that the LAGC[2 : 0] must be set to the appropriate mode to enable the peak white or average video mode.

PW_UPD	Function
0	Update gain once per video line
1	Update gain once per video field

Table xx. Peak White Update

HS POSITION CONTROL 1 (SUBADDRESS 34H)

HSB[9 : 8] (D7-D6) HS BEGIN

HS POSITION CONTROL 2 (SUBADDRESS 35H)

HSB[7 : 0] (D7-D0) HS BEGIN

The HS Begin and HS End registers allow to freely position the HS output within the video line. The values in HSB[9 : 0] are measured in pixels units from the falling edge of HS. Using both registers the user can program both, position and length of the HS output signal.

HSB[9 : 0]	Function
0...863	HSYNC pulse starts after HSB[9 : 0] pixels after falling edge of HSYNC

Table xx. HSYNC End

HS POSITION CONTROL 1 (SUBADDRESS 34H)

HSE[9 : 8] (D5-D4) HS END

HS POSITION CONTROL 3 (SUBADDRESS 36H)

HSE[7 : 0] (D7-D0) HS END

The HS End and HS Begin registers allow to freely position the HS output within the video line. The values in HSE[9 : 0] are measured in pixels units from the falling edge of HS. Using both registers the user can program both, position and length of the HS output signal.

HSE[9 : 0]	Function
0...863	HSync pulse ends after HSE[9 : 0] pixels after falling edge of HSync

Table xx. HSYNC End

POLARITY CONTROL (SUBADDRESS 37H)

PXXX (D7-D0) POLARITY CONTROL BITS

The polarity of some output signals on the ADV7185 can be changed using the table as shown below.

Bit	value	Function
PHS	0	HS active high
	1	HS active low
PHVR	0	HREF & VREF active high
	1	HREF & VREF active low
PVS	0	VS active high
	1	VS active low
PLLCREF	0	LLCREF active high
	1	LLCREF active low
PF	0	FIELD active high
	1	FIELD active low
PDV	0	DV active high
	1	DV active low
PFF	0	HFF, AEF & AFF active high
	1	HFF, AEF & AFF active low
PCLK	0	LLC1, LLC2 & QCLK active high
	1	LLC1, LLC2 & QCLK active low

Table xx. Polarity Control bits

PRELIMINARY
TECHNICAL
DATA

APPENDIX 1

BOARD DESIGN AND LAYOUT CONSIDERATIONS

The ADV7185 is a highly integrated circuit containing both precision analog and high speed digital circuitry. It has been designed to minimize interference effects on the integrity of the analog circuitry by the high speed digital circuitry. It is imperative that these same design and layout techniques be applied to the system level design such that high speed, accurate performance is achieved. The "Recommended Analog Circuit Layout" shows the analog interface between the device and monitor.

The layout should be optimized for lowest noise on the ADV7185 power and ground lines by shielding the digital inputs and providing good decoupling. The lead length between groups of VDD and GND pins should be minimized so as to minimize inductive ringing.

Ground Planes

The ground plane should encompass all ADV7185 ground pins, voltage reference circuitry, power supply bypass circuitry for the ADV7185, the analog output/input traces, and all the digital signal traces leading up to the ADV7185. The ground plane is the board's common ground plane.

Power Planes

The ADV7185 and any associated analog circuitry should have its own power plane, referred to as the analog power plane (VDD). This power plane should be connected to the regular PCB power plane (V_{CC}) at a single point through a ferrite bead. This bead should be located within three inches of the ADV7185.

The PCB power plane should provide power to all digital logic on the PC board, and the analog power plane should provide power to all ADV7185 power pins and voltage reference circuitry.

Plane-to-plane noise coupling can be reduced by ensuring that portions of the regular PCB power and ground planes do not overlay portions of the analog power plane, unless they can be arranged such that the plane-to-plane noise is common mode.

Supply Decoupling

For optimum performance, bypass capacitors should be installed using the shortest leads possible, consistent with reliable operation, to reduce the lead inductance. Best performance is obtained with 0.1 μF ceramic capacitor decoupling. Each group of VDD pins on the ADV7185 must have at least one 0.1 μF decoupling capacitor to GND. These capacitors should be placed as close as possible to the device.

It is important to note that while the ADV7185 contains circuitry to reject power supply noise, this rejection decreases with frequency. If a high frequency switching power supply is used, the designer should pay close attention to reducing power supply noise and consider using a three terminal voltage regulator for supplying power to the analog power plane.

Digital Signal Interconnect

The digital inputs to the ADV7185 should be isolated as much as possible from the analog inputs and other analog circuitry. Also, these input signals should not overlay the analog power plane.

Due to the high clock rates involved, long clock lines to the ADV7185 should be avoided to reduce noise pickup.

Any active termination resistors for the digital inputs should be connected to the regular PCB power plane (V_{CC}), and not the analog power plane.

Analog Signal Interconnect

The ADV7185 should be located as close as possible to the input connectors to minimize noise pickup and reflections due to impedance mismatch.

The video input signals should overlay the ground plane, and not the analog power plane, to maximize the high frequency power supply rejection.

Digital Outputs, especially Pixel Data Inputs and clocking signals should never overlay any of the analog signal circuitry and should be kept as far away as possible.

The ADV7185 should have no inputs left floating. Any inputs that are not required should be tied to ground.

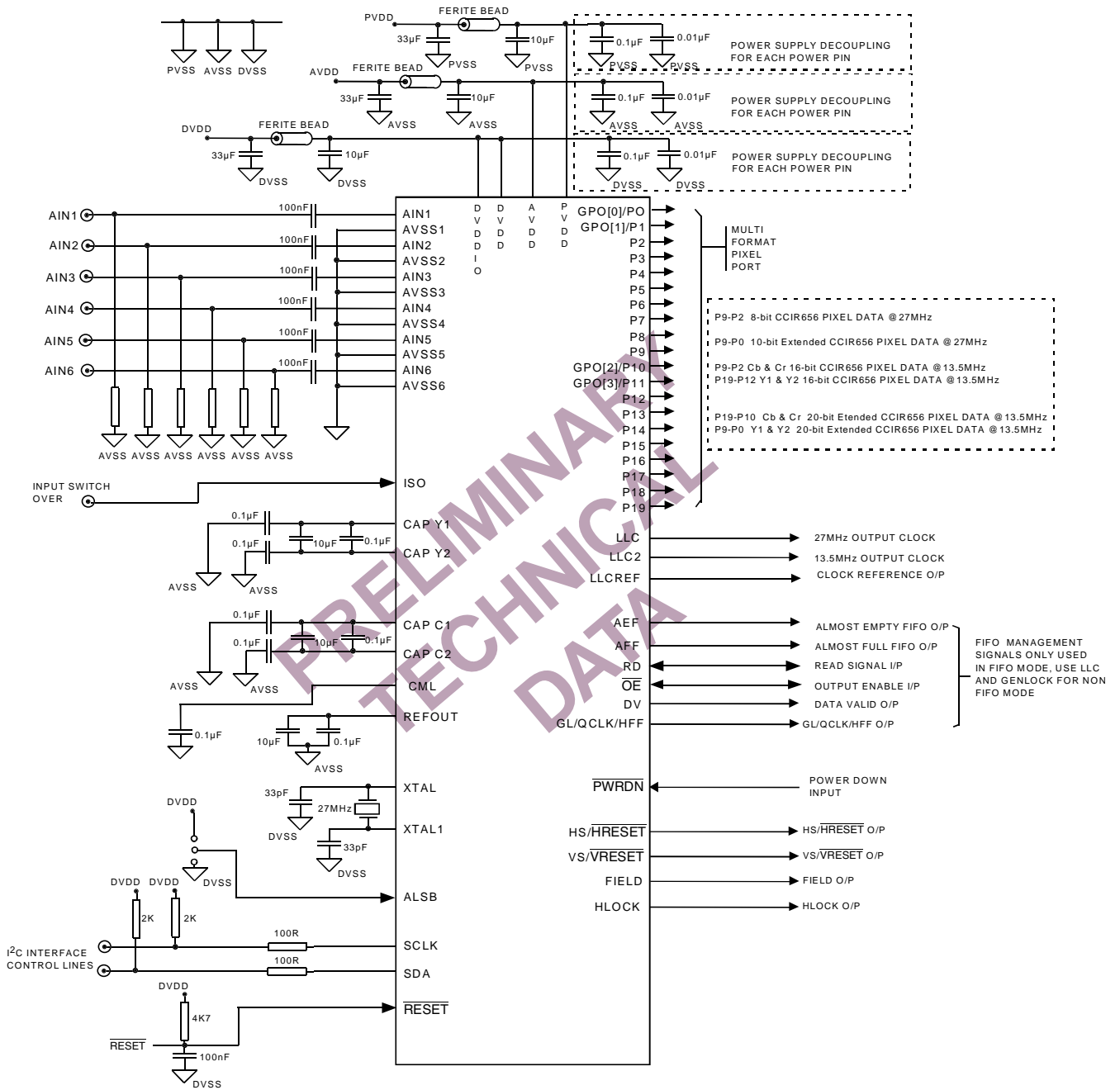

Figure 1. Recommended Circuit Layout

OUTLINE DIMENSIONS

Dimensions shown in inches and (mm).

80-Lead LQFP
(ST-80)

