

### FEATURES

- Accepts 4-to-20 mA Process Current Input Signal
- Provides Isolation and Regulated 20 V DC Loop Power for Nonisolated 2-Wire Transmitters
- +1 V to +5 V or +2 V to +10 V Output
- 1500 V rms Input/Output and Input/Power Isolation
- 250 V rms Output/Power Isolation
- 140 dB Common-Mode Rejection
- 100 Hz Signal Bandwidth
- Accuracy:  $\pm 0.05\%$
- Linearity:  $\pm 0.01\%$
- 240 V rms Field Wiring Protection
- Protected Internal Current Sense Resistor
- ANSI/IEEE C37.90.1-1989 Transient Protection
- CSA, FM and CE Approvals

### GENERAL DESCRIPTION

Model 5B42 interfaces with 2-wire transmitters to convert their 4-to-20 mA process current signal into a high accuracy output of +1 V to +5 V or +2 V to +10 V. The module provides 1500 V isolation with 140 dB CMR, 20 V regulated loop power (at a 4-to-20 mA loop current), signal filtering, and input protection against accidental line voltage connection. The industry standard 5B Series encapsulated plug-in modular package is compatible with all 5B backplanes. Modules are powered by +5 V dc,  $\pm 5\%$ .

Signal isolation is provided by transformer coupling using a proprietary technique for linear, stable performance. A demodulator on the output side of the signal transformer recovers the input signal, which is filtered and buffered to provide an accurate, low impedance, low noise output.

True three-port isolation includes common-mode voltage of: 1500 V rms between input and output, and between input and power; 250 V rms between output and power.

Accurate performance is maintained over a wide  $-40^{\circ}\text{C}$  to  $+85^{\circ}\text{C}$  operating temperature range. The 5B42's low drift design achieves an output offset drift of only  $\pm 5 \mu\text{V}/^{\circ}\text{C}$  and gain drift of  $\pm 25 \text{ ppm}/^{\circ}\text{C}$ .

The 5B42 offers significant advantages over signal conditioners that require an external current sense resistor. An external resistor is not protected from accidental connection to ac line voltages, and its error tolerance must be added to the conditioner's specified errors.

The 5B42 is trimmed and specified including its internal  $25 \Omega$  current-sense input resistor. The 5B42 signal input, loop supply and the sense resistor are all protected against accidental application of voltages, such as an ac power line, up to 240 V rms continuous. There is no need to install an external resistor on the backplane, but if one is installed, it has no effect on the 5B42 performance.

The module has a  $-3 \text{ dB}$  bandwidth of 100 Hz, an optimized 5-pole signal filter with low overshoot and exceptional output noise performance of  $200 \mu\text{V}$  peak-to-peak at 100 kHz bandwidth.

The 5B42 logic-controlled series output switch eliminates the need for external multiplexing in many applications. This low output resistance switch is controlled by an active low enable input. When the output switch is not used, ground the enable input to I/O common to turn on the switch.

### FUNCTIONAL BLOCK DIAGRAM

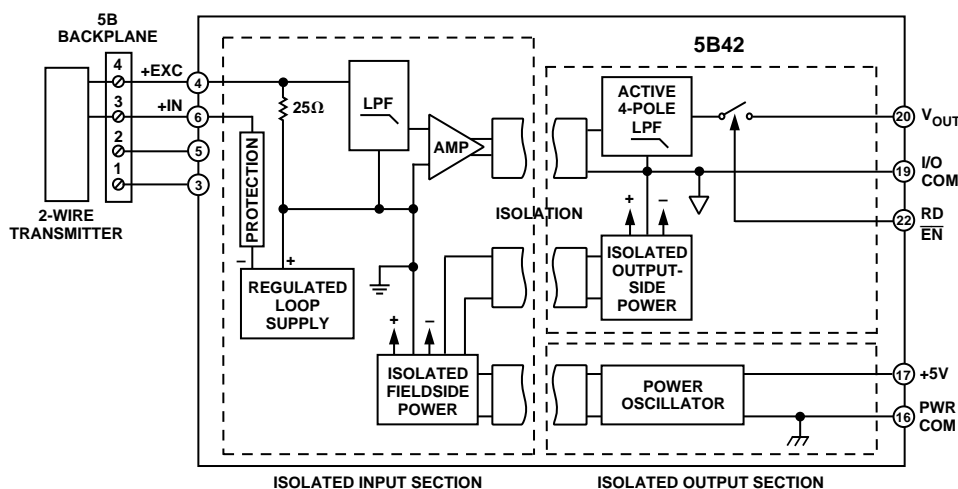

REV. 0

Information furnished by Analog Devices is believed to be accurate and reliable. However, no responsibility is assumed by Analog Devices for its use, nor for any infringements of patents or other rights of third parties which may result from its use. No license is granted by implication or otherwise under any patent or patent rights of Analog Devices.

# MODEL 5B42—SPECIFICATIONS (typical @ +25°C and $V_S = +5$ V dc)

Model	5B42
INPUT	
Standard Ranges	4 mA to 20 mA (See Table I)
Custom Range Limits	0 mA to 20 mA (See Table II)
Input Resistor <sup>1</sup>	25 $\Omega$
Loop Supply Voltage	20 V @ 4 mA to 20 mA
Normal-Mode Rejection (NMR)	
-3 dB @ 100 Hz	90 dB Per Decade Above 100 Hz
Input/Excitation/Sense Resistor Protection	
Continuous	240 V rms max
Transient	ANSI/IEEE C37.90.1-1989
COMMON-MODE VOLTAGE (CMV)	
Input-to-Output, Continuous	1500 V rms, max
Input-to-Power, Continuous	1500 V rms, max
Power-to-Output, Continuous <sup>2</sup>	250 V rms, max
COMMON-MODE REJECTION (CMR) 50 Hz/60 Hz <sup>3</sup>	140 dB
ACCURACY	
Initial @ +25°C <sup>4</sup>	$\pm 0.05\%$ Span $\pm 4$ $\mu$ A RTI <sup>5</sup>
Nonlinearity	$\pm 0.01\%$ Span
Stability vs. Temperature (-40°C to +85°C)	
Input Offset	$\pm 0.5$ $\mu$ V/°C
Output Offset	$\pm 5$ $\mu$ V/°C
Gain	$\pm 25$ ppm of Reading/°C
OUTPUT	
Range (See Tables I and II)	
5B42-01	+1 V to +5 V
5B42-02	+2 V to +10 V
Resistance	25 $\Omega$
Bandwidth, -3 dB	100 Hz
Step Response Time (90% Span)	4 ms
Noise	
Input, 0.1 Hz to 10 Hz	10 nA rms
Output, 100 kHz	200 $\mu$ V pk-pk
Protection	Continuous Short to Ground
Current Limit	$\pm 20$ mA
Enable Time (C Load = 0 pF to 2000 pF)	6 $\mu$ s to $\pm 1$ mV of $V_{OUT}$
Enable Control	
Max Logic "0"	+0.8 V
Min Logic "1"	+2.4 V
Max Logic "1"	+36 V
Input Current "0," "1"	0.5 $\mu$ A
POWER SUPPLY	
Voltage, Rated Performance	+5 V dc $\pm 5\%$
Current	
@ Transmitter Load of 20 mA	200 mA
@ Transmitter Load of 4 mA	100 mA
Sensitivity	$\pm 1$ $\mu$ V/% RTI <sup>5</sup>
CASE SIZE, Maximum	2.275" $\times$ 2.325" $\times$ 0.595" (57.8 mm $\times$ 59.1 mm $\times$ 15.1 mm)
WEIGHT	70 grams
ENVIRONMENTAL	
Temperature Range, Rated Performance	-40°C to +85°C
Storage Temperature	-40°C to +85°C
Relative Humidity	0% to 93% @ +40°C, Noncondensing
RFI Susceptibility	$\pm 0.5\%$ Span Error @ 400 MHz, 5 W, 3'

## NOTES

<sup>1</sup>A precision 25  $\Omega$  current-sense input resistor is internal to the 5B42.

<sup>2</sup>The user's board layout must separate Power Ground from I/O Common and when the 5B42 output switch is not used, ground the enable input to I/O Common. Power-to-Output CMV is not available when the 5B42 is installed on a 5B Series backplane.

<sup>3</sup>The use of shielded cable from the signal source to the 5B42 inputs is recommended to maintain CMR performance.

<sup>4</sup>Includes the combined effects of repeatability, hysteresis and nonlinearity.

<sup>5</sup>Referenced to Input.

Specifications subject to change without notice.

**Table I. Standard Model Input/Output Ranges\***

Model	Input Range	Output Range
5B42-01	4 mA to 20 mA	+1 V to +5 V
5B42-02	4 mA to 20 mA	+2 V to +10 V

\*Custom input/output ranges are available. See Table II.

**Table II. Custom Model Ordering Guide**

Order Model: **5B42-CUSTOM** plus Customer Specified Information

### Customer Specified Information:

Input Range	Output Range	
	Low Limit	High Limit
Available Range 0 mA to 20 mA*	0 V	10 V

\*There is no loop power supplied by the 5B42 at 0 mA input.