

AD720/AD721

FEATURES

- Composite Video Output
- Chrominance and Luminance (S-Video) Outputs
- No External Filters or Delay Lines Required
- Drives 75 Ω Reverse-Terminated Loads
- Compact 28-Pin PLCC
- Logic Selectable NTSC or PAL Encoding Modes
- Automatically Selects Proper Chrominance Filter Cutoff Frequency for Encoding Standard
- Logic Selectable Encode or Power-Down Mode (AD720 Only)
- Logic Selectable Encode or Bypass Mode (AD721 Only)
- Low Power: 200 mW typical

APPLICATIONS

- RGB to NTSC or PAL Encoding
- Drive RGB Signals into 75 Ω Load (AD721 Only)

PRODUCT DESCRIPTION

The AD720 and AD721 RGB to NTSC/PAL Encoders convert red, green and blue color component signals into their corresponding luminance (baseband amplitude) and chrominance

(subcarrier amplitude and phase) signals in accordance with either NTSC or PAL standards. These two outputs are also combined to provide a composite video output. All three outputs are available separately at voltages of twice the standard signal levels as required for driving 75 Ω reverse terminated cables. The AD721 also features a bypass mode, in which the RGB inputs may bypass the encoder section of the IC via three gain-of-two amplifiers suitable for driving 75 Ω reverse terminated cables.

The AD720 and AD721 provide a complete, fully calibrated function, requiring only termination resistors, bypass capacitors, a clock input at four times the subcarrier frequency, and a composite sync pulse. There are two control inputs: one input selects the TV standard (NTSC/PAL) and the other (ENCD) powers down most sections of the chip when the encoding function is not in use (AD720) or activates the triple bypass buffer to drive the RGB signals when RGB encoding is not required (AD721). All logical inputs are CMOS compatible. The chip operates from ± 5 V supplies.

(continued on page 5)

FUNCTIONAL BLOCK DIAGRAM

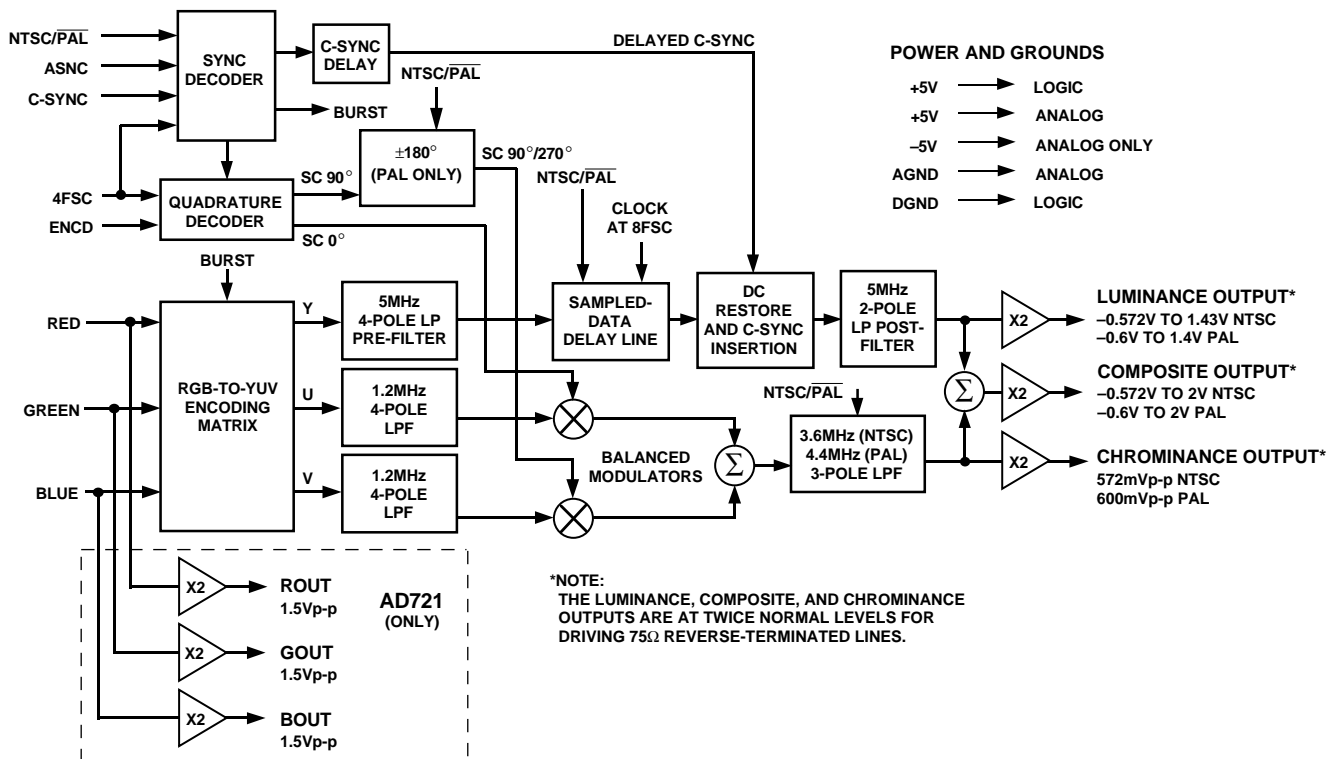

REV. 0

Information furnished by Analog Devices is believed to be accurate and reliable. However, no responsibility is assumed by Analog Devices for its use, nor for any infringements of patents or other rights of third parties which may result from its use. No license is granted by implication or otherwise under any patent or patent rights of Analog Devices.

AD720/AD721—SPECIFICATIONS (T_A = +25°C and supplies = ±5 V unless otherwise noted)

Parameter	Conditions	Min	Typ	Max	Unit
SIGNAL INPUTS (RDIN, GRIN, BLIN)					
Input Amplitude	NTSC PAL		714 700		mV mV
Input Resistances ¹					
RDIN with Respect to AGND			2.3		kΩ
GRIN with Respect to AGND			4.2		kΩ
BLIN with Respect to AGND			4.2		kΩ
Input Capacitance			5		pF
LOGIC INPUTS (C-SYNC, 4FSC, ENCD, NTSC)					
Logic LO Input Voltage				1	V
Logic HI Input Voltage		4			V
Logic LO Input Current (DC)			<1		μA
Logic HI Input Current (DC)			<1		μA
BYPASS AMPLIFIERS (AD721 Only)					
Gain Error	Nominal Gain of ×2 ²	-5		+5	%
Small Signal -3 dB Bandwidth		100			MHz
Output Offset Voltage (Active State)		-50		+50	mV
Output Voltage (Inactive State)		-50		+50	mV
VIDEO OUTPUTS³ (LUMA, CRMA, CMPS)					
Luminance (LUMA) Output					
Bandwidth			5		MHz
Gain Error		-5	±1	+5	%
Linearity			±0.1		%
Sync Level	NTSC PAL	252	286 300	320	mV mV
Chrominance (CRMA) Output					
Bandwidth	NTSC PAL		3.6 4.4		MHz MHz
Color Burst Amplitude	NTSC PAL	257	286 300	315	mV p-p mV p-p
Absolute Gain Error		-15	±5	+15	%
Absolute Phase Error			±3		Degrees
Chroma/Luma Time Alignment ⁴	NTSC		-170		ns
Composite Output					
Absolute Gain Error		-5	±1	+5	%
Differential Gain	With Respect to Chroma Channel		0.1		%
Differential Phase	With Respect to Chroma Channel		0.1		Degrees
Output Offset Voltage	Chroma, Luma, or Composite Outputs		50	100	mV
Chroma Feedthrough	Monochrome Input		20	55	mV p-p
POWER SUPPLIES (APOS, DPOS, VNEG)					
Recommended Supply Range	Dual Supply	±4.75		±5.25	V
Full Output Current ⁵	-5 V Supply		35		mA
	+5 V Supply		67		mA
Zero Signal Quiescent Current	-5 V Supply	10	20	35	mA
	+5 V Supply	10	20	35	mA
Bypass Mode Quiescent Current (AD721 Only)	-5 V Supply		14	20	mA
	+5 V Supply		14	20	mA

NOTES

¹Input scaling resistors provide best scaling accuracy when source resistance is 37.5 Ω (75 Ω reverse-terminated input).

²Required for driving a 75 Ω double reverse terminated load.

³All outputs are measured at a reverse-terminated load; voltages at IC pins are twice those specified here.

⁴This is a predistortion (per FCC specifications) that compensates for the chroma/luma delay in the low-pass filter that separates the luminance and chrominance signals in a television receiver.

⁵CRMA, LUMA, and CMPS outputs are all connected to 75 Ω reverse-terminated loads; full-white signal for entire field.

Specifications shown in **boldface** are tested on all production units at final electrical test. Results from those tests are used to calculate outgoing quality levels. All min and max specifications are guaranteed, although only those shown in **boldface** are tested on all production units.

Specifications subject to change without notice.

ABSOLUTE MAXIMUM RATINGS*

Supply Voltage $\pm V_S$ ± 6 V
 Internal Power Dissipation 600 mW
 Operating Temperature Range 0°C to +70°C
 Storage Temperature Range -65°C to +150°C
 Lead Temperature, Soldering 60 sec +300°C

NOTE

*Stresses above those listed under "Absolute Maximum Ratings" may cause permanent damage to the device. This is a stress rating only, and functional operation of the device at these or any other conditions above those indicated in the operational section of this specification is not implied. Exposure to absolute maximum rating conditions for extended rating conditions for extended periods may affect device reliability.

Thermal characteristics: 28-pin plastic package: $\theta_{JA} = 100^\circ\text{C}$.

ORDERING GUIDE

Model	Temperature Range	Package	Package Option
AD720JP	0°C to +70°C	28-Pin PLCC	P-28A
AD721JP	0°C to +70°C	28-Pin PLCC	P-28A

PIN CONNECTIONS

28-Lead Plastic Leaded Chip Carrier (PLCC) Package P-28A

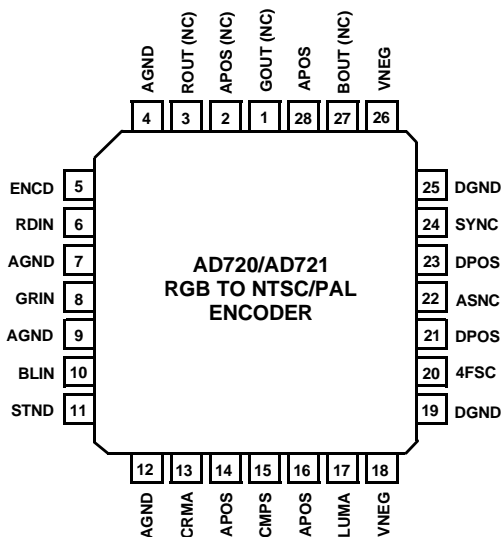

NOTE:
CONNECTIONS IN () PERTAIN ONLY TO AD720

PIN DESCRIPTIONS

Pin	Mnemonic*	Description*
1	(NC) GOUT	(No Connection) Green Bypass Buffer
2	(NC) APOS	(No Connection) Analog Positive Supply; +5 V \pm 5%
3	(NC) ROUT	(No Connection) Red Bypass Buffer
4	AGND	Analog Ground Connection
5	ENCD	A Logical High Enables the NTSC/PAL Encode Mode (A Logical Low Powers Down the Chip) A Logical Low Enables the RGB Bypass Mode
6	RDIN	Red Component Video Input 0 mV to 714 mV for NTSC 0 mV to 700 mV for PAL
7	AGND	Analog Ground Connection
8	GRIN	Green Component Video Input 0 mV to 714 mV for NTSC 0 mV to 700 mV for PAL
9	AGND	Analog Ground Connection
10	BLIN	Blue Component Video Input 0 mV to 714 mV for NTSC 0 mV to 700 mV for PAL
11	STND	A Logical High Input Selects NTSC Encoding A Logical Low Input Selects PAL Encoding CMOS Logic Levels
12	AGND	Analog Ground Connection
13	CRMA	Chrominance Output; Subcarrier Only** 572 mV Peak-to-Peak for NTSC 600 mV Peak-to-Peak for PAL
14	APOS	Analog Positive Supply; +5 V \pm 5%
15	CMPS	Composite Video Output** -572 mV to 2 V for NTSC -600 mV to 2 V for PAL
16	APOS	Analog Positive Supply; +5 V \pm 5%
17	LUMA	Luminance Plus SYNC Output** -572 mV to 1.43 V for NTSC -600 mV to 1.4 V for PAL
18	VNEG	System Negative Supply; -5 V \pm 5%
19	DGND	Digital Ground Connection
20	4FSC	Clock Input at Four Times the Subcarrier Frequency 14.318 180 MHz for NTSC 17.734 480 MHz for PAL CMOS Logic Levels
21	DPOS	Digital Positive Supply; +5 V \pm 5%
22	ASNC	A Logical High Input Resets the Subcarrier Phase Every Frame A Logical Low Input Resets the Subcarrier Phase Every Fourth Frame CMOS Logic Levels
23	DPOS	Digital Positive Supply; +5 V \pm 5%
24	SYNC	Input for Composite Television Synchronization Pulses Negative Sync Pulses CMOS Logic Levels
25	DGND	Digital Ground Connections (One of Two)
26	VNEG	System Negative Supply; -5 V \pm 5%
27	(NC) BOUT	(No Connection) Blue Bypass Buffer
28	APOS	Analog Positive Supply; +5 V \pm 5%

*() pertain only to AD720.

**The luminance, chrominance, and composite outputs are at twice normal levels for driving 75 Ω reverse-terminated lines.

CAUTION

ESD (electrostatic discharge) sensitive device. Electrostatic charges as high as 4000 V readily accumulate on the human body and test equipment and can discharge without detection. Although the AD720/AD721 features proprietary ESD protection circuitry, permanent damage may occur on devices subjected to high energy electrostatic discharges. Therefore, proper ESD precautions are recommended to avoid performance degradation or loss of functionality.



AD720/AD721-Typical Characteristics

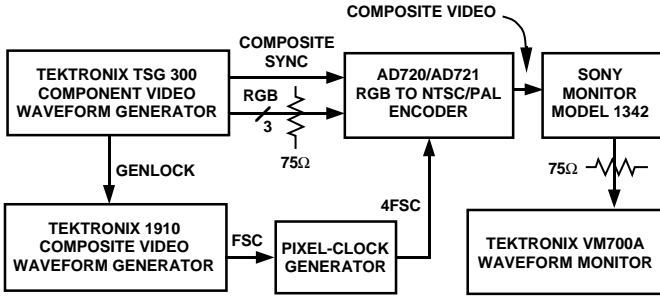

Figure 1. AD720/AD721 Evaluation Setup

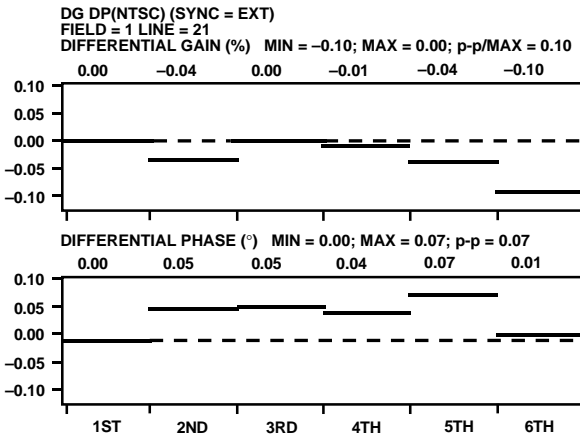

Figure 2. Composite Output Differential Phase and Gain, NTSC (Nulled to Chroma Output)

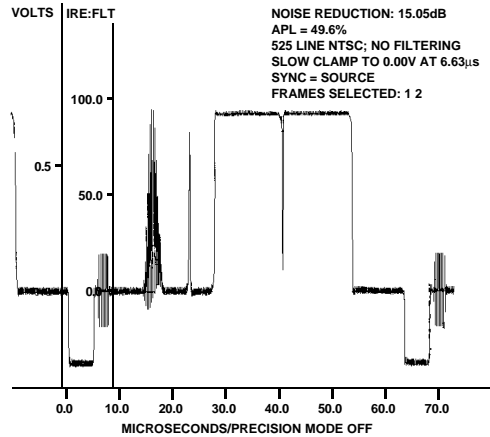

Figure 3. Modulated Pulse and Bar, NTSC

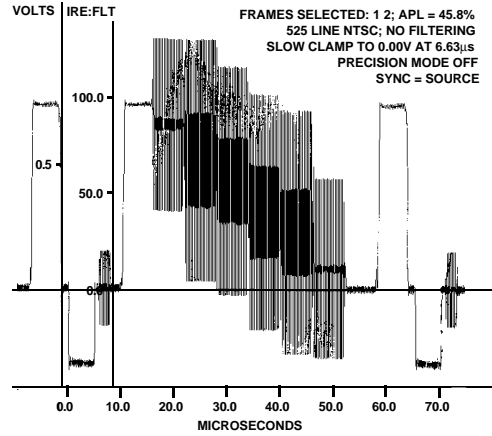

Figure 4. 100% Color Bars, NTSC

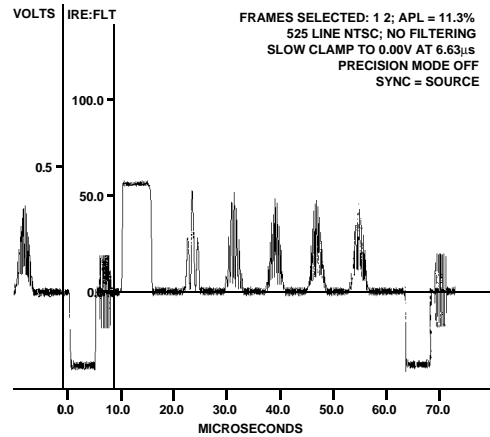

Figure 5. Multipulse, NTSC

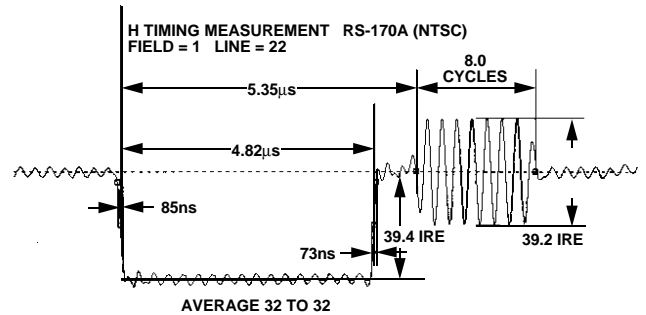

Figure 6. Horizontal Timing, NTSC

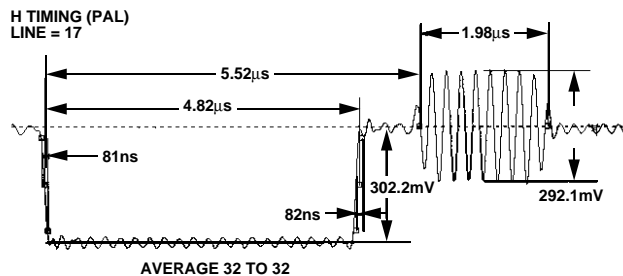

Figure 7. Horizontal Timing, PAL

(continued from page 1)

All required low-pass filters are on chip. After the input signals pass through a precision RGB to YUV encoding matrix, two on-chip low-pass filters limit the bandwidth of the U and V color difference signals to 1.2 MHz prior to quadrature modulation of the color subcarrier; a third low-pass filter at 3.6 MHz (NTSC) or 4.4 MHz (PAL) follows the modulators to limit the harmonic content of the output.

Delays in the U and V chroma filters are matched by an on-chip sampled data delay line in the Y signal path; to prevent aliasing, prefilter at 5 MHz is included ahead of the delay line and a post filter at 5 MHz is added after the delay line to suppress harmonics in the output. These low-pass filters are optimized for minimum pulse overshoot. The overall delay is about 170 ns, which precompensates for delays in the filters used to decode the NTSC or PAL signal in a television receiver. (This precompensation delay is already present in TV broadcasts.)

The AD720 and AD721 are available in a 28-pin plastic leaded chip carrier for the 0°C to +70°C commercial temperature range.

THEORY OF OPERATION

Referring to the AD720/AD721 block diagram (Figure 8), the RGB inputs (each 0 mV to 714 mV in NTSC or 0 mV to 700 mV in PAL) are first encoded into luminance and color difference signals. The luminance signal is called the “Y” signal and the color-difference signals are called U and V. The RGB inputs are encoded into the YUV format using the transformation

$$Y = 0.299R + 0.587G + 0.114B$$

$$U = 0.493 (B - Y)$$

$$V = 0.877 (R - Y)$$

For NTSC operation, the chroma amplitude is increased by the factor 1.06 prior to summation with the luminance output. The burst signal is inserted into the Y channel in the encoding matrix.

The three outputs of the encoding matrix, now transformed into Y, U, and V components, take two paths. The Y (luminance) signal is passed through a delay line consisting of a prefilter, a sampled-data delay line, and a post filter. The pre- and post-filters prevent aliasing of harmonics back into the baseband video. The overall delay is a nominal -170 ns relative to the chrominance signal, in keeping with broadcast requirements to compensate for delays introduced by the filters in the decoding process.

The U and V components pass through 4-pole modified Bessel low-pass filters with a 1.2 MHz -3 dB frequency to prevent aliasing in the balanced modulators, where they modulate a 3.579 545 000 MHz (NTSC) or 4.433 618 750 MHz (PAL) signal via a pair of balanced modulators driven in quadrature by the color subcarrier.

The AD720/AD721 4FSC input drives a digital divide-by-4 circuit (two flip-flops) to create the quadrature signal. The reference phase 0° is used for the U signal. In the NTSC mode, the V signal is modulated at 90°, but in the PAL mode, the V modulation input alternates between 90° and 270° at half the line rate as required by the PAL standard. The outputs of the balanced modulators are summed and low-pass filtered to remove harmonics.

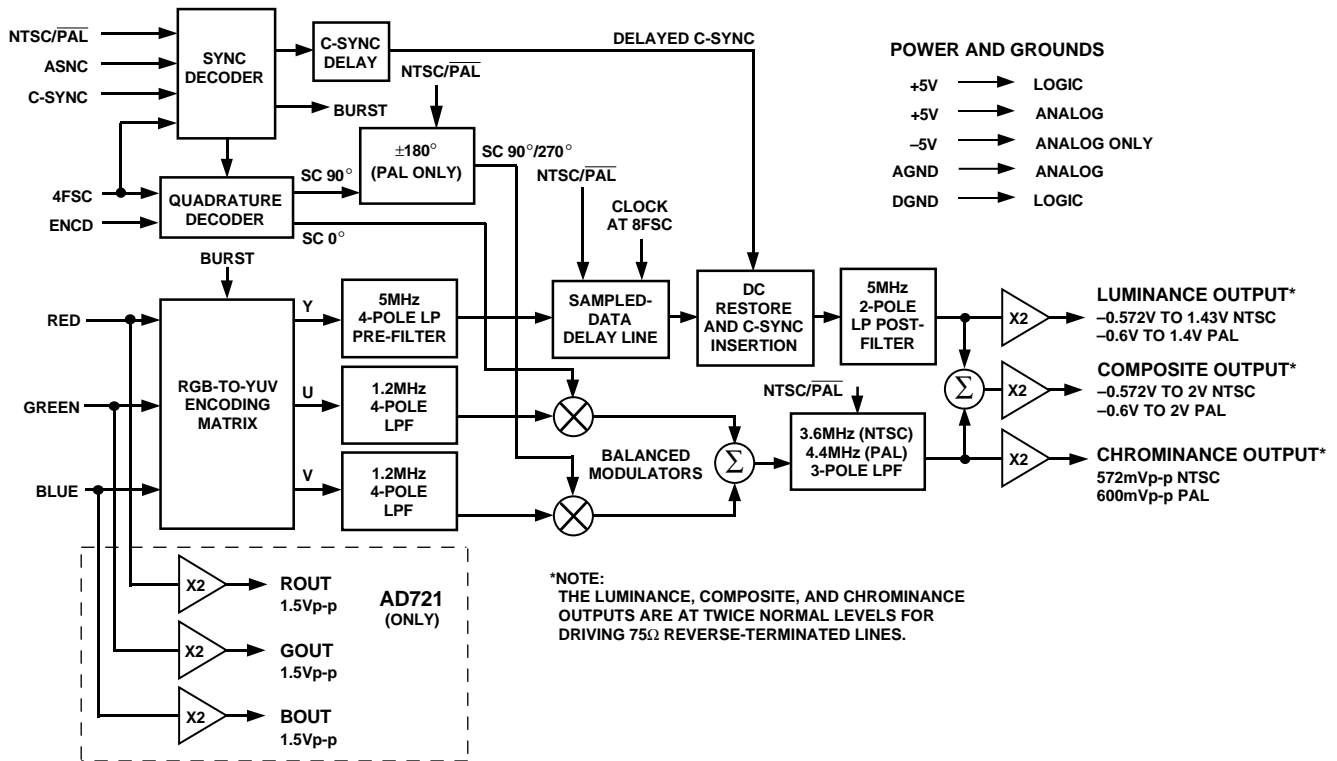

Figure 8. AD720/AD721 Functional Block Diagram

AD720/AD721

The filtered output is summed with the luminance signal to create a composite video signal. The separate luminance, chrominance, and composite video signals are amplified by gain-of-two amplifiers for driving 75 Ω reverse-terminated lines. The separate luminance and chrominance outputs together are known as “S-Video.”

The digital section of the AD720/AD721 is clocked by the 4FSC input. It measures the width of pulses in the composite sync input to separate vertical, horizontal, and serration pulses and to insert the subcarrier burst only after a valid horizontal sync pulse.

Asserting the ENCD pin to a logical low routes the AD721’s RGB inputs through three gain-of-two bypass buffers for driving 75 Ω reverse-terminated lines, bypassing the encoder section of the AD721. The triple bypass amplifier is utilized to overcome the loading effects of a “TV-out” connection on the RGB monitor output. When a video encoder is connected to outputs of a current-out video RAMDAC or VGA controller, the R, G, and B signals to the monitor are loaded-down. This requires the use of a gain block to properly drive the monitor.

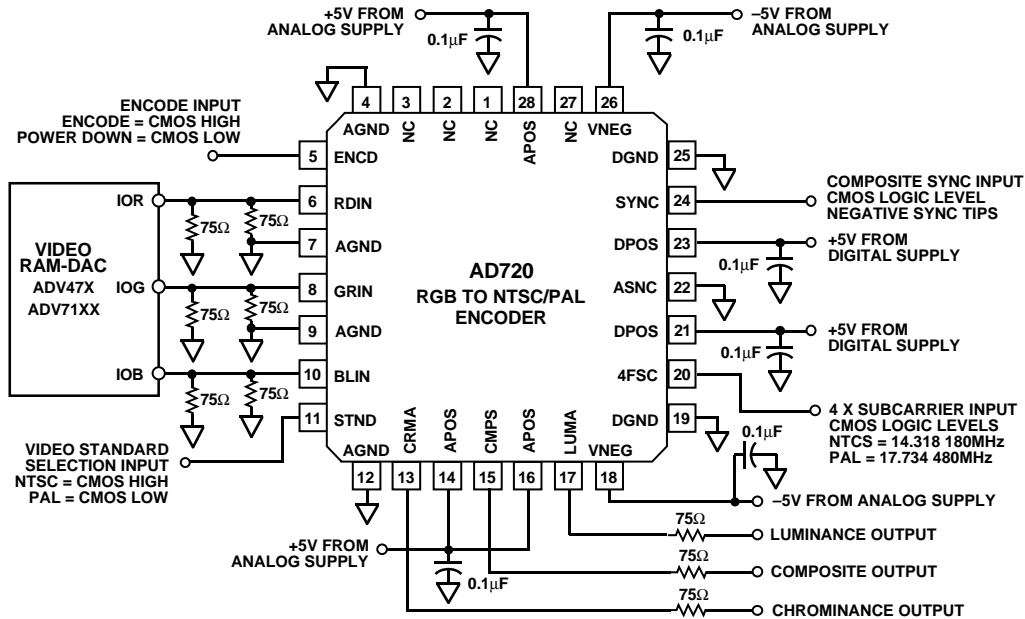

Figure 9. AD720 Application

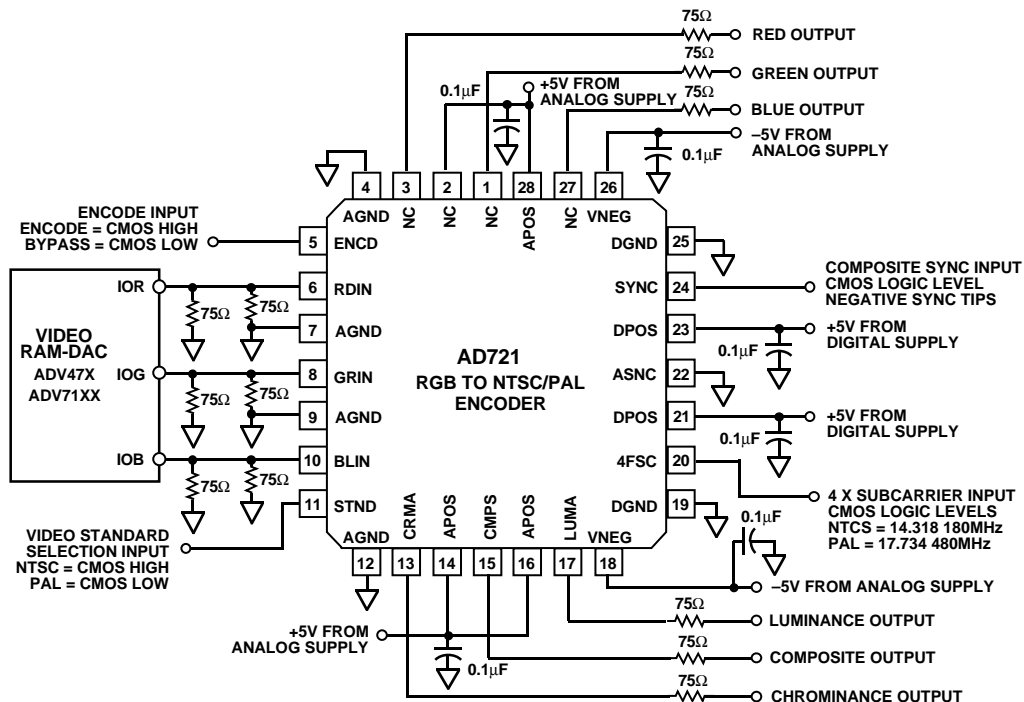

Figure 10. AD721 Application

APPLYING THE AD720/AD721

Figure 9 shows the application of the AD720 and Figure 10 shows the application of the AD721. Note that the AD720 and AD721 differ from other analog encoders because they are dc coupled. This means that, for example, the expected RGB inputs are 0 mV to 714 mV in NTSC and 0 mV to 700 mV in PAL. The luminance, chrominance, and composite outputs are also dc coupled. These outputs can drive a 75 Ω reverse-terminated load. Unused outputs should be terminated with 150 Ω resistors.

The RGB data must be supplied to the AD720/AD721 at NTSC or PAL rates, interlaced format. Various VGA chip set vendors support this mode of operation. Most computers supply RGB outputs in noninterlaced format at higher data rates than NTSC and PAL, which means that “outboard” encoders must supply some form of timing conversion before the RGB data reaches the AD720/AD721.

Note also that the AD720/AD721 does not have internal dc restoration and does not accept sync on green. The composite sync input is a separate, CMOS logical-level input and must be synchronized with the 4FSC input, which serves as the master clock for the AD720/AD721.

The AD720/AD721 does not implement two elements of the PAL and NTSC standards. In NTSC operation, it does not support the 7.5 IRE unit setup (1 IRE unit = 7.14 mV)—this must be added via software using the RGB inputs. Many RAM-DACs, such as the Analog Devices ADV471 and ADV478, offer a logic-selectable setup mode. In PAL operation, the AD720/AD721 does not implement a 25 Hz subcarrier offset.

Decoupling and Grounding

Referring to the pin descriptions, the AD720/AD721 uses multiple analog grounds, digital grounds, digital positive supply inputs, analog positive supply inputs, and analog negative supply inputs in order to maximize isolation between analog and digital signal paths.

The most sensitive input of the AD720/AD721 is the 4FSC pin: any noise on this pin directly affects the subcarrier and causes degradation of the picture. Digital and analog grounds should be kept separate and brought together at a single point.

All power supply pins should be decoupled using 0.1 μ F ceramic capacitors located as close to the AD720/AD721 as possible. In addition, ferrite beads may be slipped over the power supply leads to reduce high frequency noise.

If a high speed RAM-DAC is used (e.g., capable of 80 MHz operation with subnanosecond rise times), care must be taken to properly terminate the input printed-circuit-board traces to the AD720/AD721. Otherwise, ringing on these traces may occur and cause degradation of the picture.

APPLICATIONS HINTS

In applying the AD720/AD721, problems may arise due to incorrect input signals. A few common situations follow.

Fade to Black or White—Invalid Horizontal Sync Pulses

Some systems produce sync pulses that are longer or shorter than the NTSC and PAL standards specify. The digital sync

separator in the AD720/AD721 ignores horizontal sync pulses that are too long or too short. Figure 11 shows the timing windows for valid NTSC and PAL horizontal sync pulses.

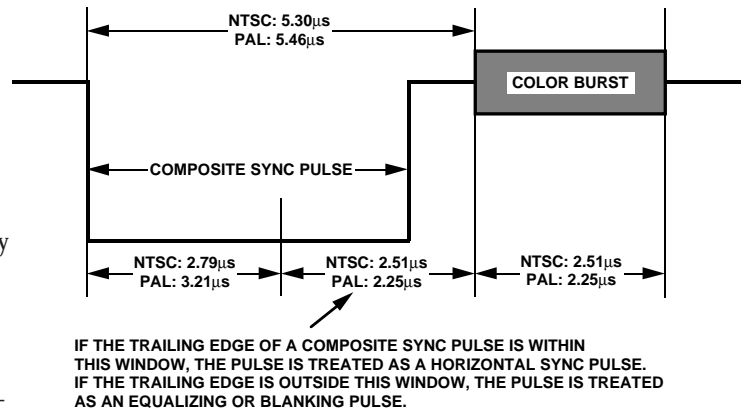

Figure 11. NTSC and PAL Timing for Valid Horizontal Sync Pulses

When the horizontal sync pulses are too long or too short, a dc offset voltage (due to charge storage) increases on the output of the sampled data delay line’s auto-zero amplifier. Normally, this offset voltage is removed at the beginning of every line, as signified by the horizontal sync pulse. Without the horizontal sync pulse, the dc offset on the auto-zero amplifier increases over time (usually about three to five minutes) until it overrides the luminance information. The end result is a slow fade to black or white.

Color Flickering—Asynchronous Operation

The AD720/AD721 requires that its 4FSC and composite sync signals be synchronized. In most systems, when the two signals are synchronized, the composite sync signal is generated using a 4FSC signal as the reference. After every four frames, the AD720/AD721 resets the phase quadrature generator. When the CSYNC and 4FSC are synchronized, this reset is transparent to the system because the reference phase does not change. When the CSYNC and 4FSC are not synchronized, the difference between the reference phase and its new value upon reset causes an instantaneous color shift, which appears as a flickering in the color.

Adding NTSC Setup

The easiest way to add the 7.5 IRE unit¹ setup is to use a ADV471/478 or ADV477/475 or ADV473 type RAM-DAC, which have a logic-selectable setup (called “pedestal” on some data sheets and “setup” on others).

Color Fidelity

A source impedance other than 37.5 Ω (75 Ω ||75 Ω —a reverse-terminated 75 Ω input) can cause errors in the YUV encoding matrix, which is basically resistive and depends on the correct source impedance for accuracy. Figures 9 and 10 show the correct interface between a RAM-DAC and the AD720 and AD721 respectively, using 75 Ω reverse-terminated connections.

NOTE
¹IRE unit = 7.14 mV.

OUTLINE DIMENSIONS

Dimensions shown in inches and (mm).

28-Lead Plastic Leaded Chip Carrier (PLCC) Package

P-28A

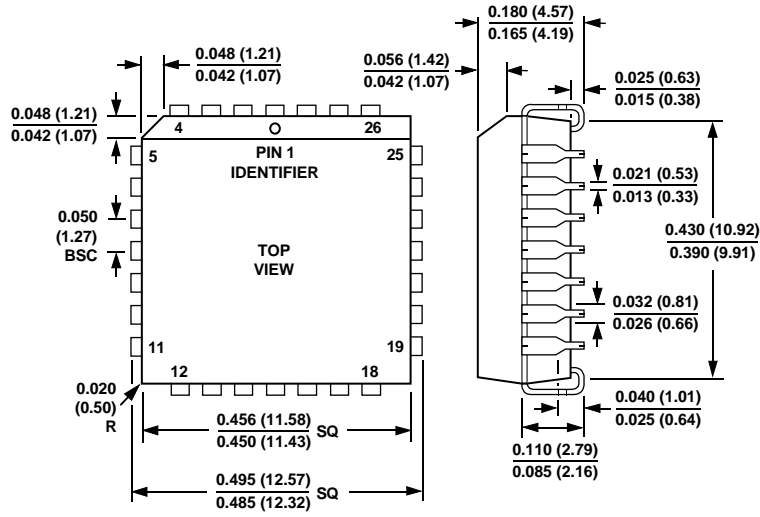

C1932-7.5-7/94

PRINTED IN U. S. A.