

OP-290

FEATURES

- **Single/Dual Supply Operation** +1.6V to +36V
..... ±0.8V to ±18V
- **True Single-Supply Operation; Input and Output Voltage Ranges Include Ground**
- **Low Supply Current (per amplifier)** 20µA Max
- **High Output Drive** 5mA Min
- **Low Input Offset Voltage** 200µV Max
- **High Open-Loop Gain** 700V/mV Min
- **Outstanding PSRR** 5.6µV/V Max
- **Industry Standard 8-Pin Dual Pinout**
- **Available in Die Form**

dual supplies of ±0.8V to ±18V. Input voltage range includes the negative rail allowing the OP-290 to accommodate input signals down to ground in single supply operation. The OP-290's output swing also includes ground when operating from a single supply, enabling "zero-in, zero-out" operation.

The OP-290 draws less than 20µA of quiescent supply current per amplifier, while able to deliver over 5mA of output current to a load. Input offset voltage is below 200µV eliminating the need for external nulling. Gain exceeds 700,000 and common-mode rejection is better than 100dB. The power

Continued

ORDERING INFORMATION †

T _A = +25°C V _{os} MAX (mV)	PACKAGE			OPERATING TEMPERATURE RANGE
	CERDIP 8-PIN	PLASTIC	LCC 20-CONTACT	
200	OP290AZ*	-	OP290ARC/883	MIL
200	OP290EZ	-	-	XIND
300	OP290FZ	-	-	XIND
500	-	OP290GP	-	XIND
500	-	OP290GS††	-	XIND

* For devices processed in total compliance to MIL-STD-883, add /883 after part number. Consult factory for 883 data sheet.

† Burn-in is available on commercial and industrial temperature range parts in CerDIP, plastic DIP, and TO-can packages.

†† For availability and burn-in information on SO and PLCC packages, contact your local sales office.

GENERAL DESCRIPTION

The OP-290 is a high performance micropower dual op amp that operates from a single supply of +1.6V to +36V or from

PIN CONNECTIONS

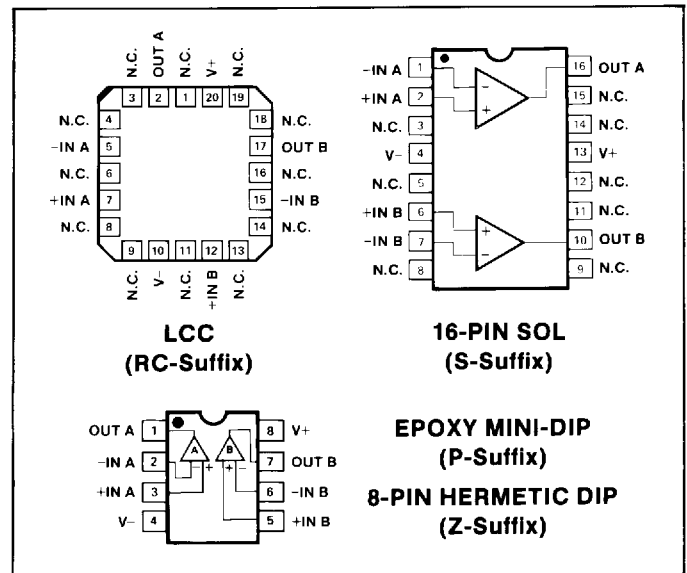

SIMPLIFIED SCHEMATIC (One of two amplifiers is shown.)

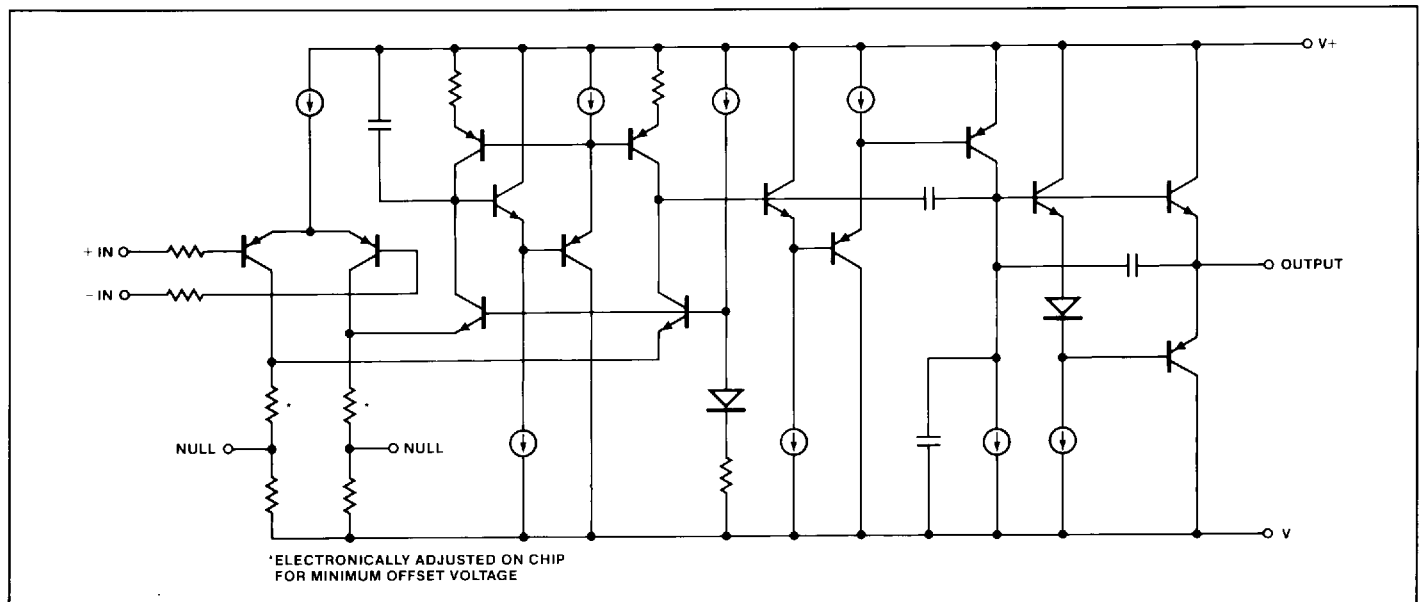

OP-290

GENERAL DESCRIPTION *Continued*

supply rejection ratio of under $5.6\mu\text{V}/\text{V}$ minimizes offset voltage changes experienced in battery powered systems. The low offset voltage and high gain offered by the OP-290 bring precision performance to micropower applications. The minimal voltage and current requirements of the OP-290 suit it for battery and solar powered applications, such as portable instruments, remote sensors, and satellites. For a single op amp, see the OP-90; for a quad, see the OP-490.

ABSOLUTE MAXIMUM RATINGS (Note 1)

Supply Voltage	$\pm 18\text{V}$
Differential Input Voltage	$[(V-) - 20\text{V}]$ to $[(V+) + 20\text{V}]$
Common-Mode Input Voltage	$[(V-) - 20\text{V}]$ to $[(V+) + 20\text{V}]$
Output Short-Circuit Duration	Indefinite
Storage Temperature Range	
P, RC, S, Z Package	-65°C to $+150^\circ\text{C}$

Operating Temperature Range

OP-290A	-55°C to $+125^\circ\text{C}$
OP-290E, OP-290F, OP-290G	-40°C to $+85^\circ\text{C}$
Junction Temperature (T_j)	-65°C to $+150^\circ\text{C}$
Lead Temperature Range (Soldering, 60 sec)	300°C

PACKAGE TYPE	θ_{JA} (Note 2)	θ_{JC}	UNITS
8-Pin Hermetic DIP (Z)	134	12	$^\circ\text{C}/\text{W}$
8-Pin Plastic DIP (P)	96	37	$^\circ\text{C}/\text{W}$
20-Contact LCC (RC)	88	33	$^\circ\text{C}/\text{W}$
16-Pin SOL (S)	92	27	$^\circ\text{C}/\text{W}$

NOTES:

- Absolute maximum ratings apply to both DICE and packaged parts, unless otherwise noted.
- θ_{JA} is specified for worst case mounting conditions, i.e., θ_{JA} is specified for device in socket for CerDIP, P-DIP, and LCC packages; θ_{JA} is specified for device soldered to printed circuit board for SOL package.

ELECTRICAL CHARACTERISTICS at $V_S = \pm 1.5\text{V}$ to $\pm 15\text{V}$, $T_A = +25^\circ\text{C}$, unless otherwise noted.

PARAMETER	SYMBOL	CONDITIONS	OP-290A/E			OP-290F			OP-290G			UNITS
			MIN	TYP	MAX	MIN	TYP	MAX	MIN	TYP	MAX	
Input Offset Voltage	V_{OS}		—	50	200	—	75	300	—	125	500	μV
Input Offset Current	I_{OS}	$V_{CM} = 0\text{V}$	—	0.1	3	—	0.1	5	—	0.1	5	nA
Input Bias Current	I_B	$V_{CM} = 0\text{V}$	—	4.0	15	—	4.0	20	—	4.0	25	nA
Large Signal Voltage Gain	A_{VO}	$V_S = \pm 15\text{V}$, $V_O = \pm 10\text{V}$ $R_L = 100\text{k}\Omega$	700	1200	—	500	1000	—	400	800	—	V/mV
		$R_L = 10\text{k}\Omega$	350	600	—	250	500	—	200	400	—	
		$R_L = 2\text{k}\Omega$	125	250	—	100	200	—	100	200	—	
		$V_+ = 5\text{V}$, $V_- = 0\text{V}$, $1\text{V} < V_O < 4\text{V}$ $R_L = 100\text{k}\Omega$	200	400	—	125	300	—	100	250	—	
		$R_L = 10\text{k}\Omega$	100	180	—	75	140	—	70	140	—	
Input Voltage Range	IVR	$V_+ = 5\text{V}$, $V_- = 0\text{V}$ $V_S = \pm 15\text{V}$ (Note 1)	0/4	—	—	0/4	—	—	0/4	—	—	V
Output Voltage Swing	V_O	$V_S = \pm 15\text{V}$ $R_L = 10\text{k}\Omega$	± 13.5	± 14.2	—	± 13.5	± 14.2	—	± 13.5	± 14.2	—	V
		$R_L = 2\text{k}\Omega$	± 10.5	± 11.5	—	± 10.5	± 11.5	—	± 10.5	± 11.5	—	
		$V_+ = 5\text{V}$, $V_- = 0\text{V}$ $R_L = 2\text{k}\Omega$	4.0	4.2	—	4.0	4.2	—	4.0	4.2	—	V
	V_{OL}	$V_+ = 5\text{V}$, $V_- = 0\text{V}$ $R_L = 10\text{k}\Omega$	—	10	50	—	10	50	—	10	50	μV
Common-Mode Rejection	CMR	$V_+ = 5\text{V}$, $V_- = 0\text{V}$, $0\text{V} < V_{CM} < 4\text{V}$	90	115	—	80	100	—	80	100	—	dB
		$V_S = \pm 15\text{V}$, $-15\text{V} < V_{CM} < 13.5\text{V}$	100	120	—	90	120	—	90	120	—	
Power Supply Rejection Ratio	PSRR		—	1.0	5.6	—	1.0	5.6	—	3.2	10	$\mu\text{V}/\text{V}$
Supply Current (All Amplifiers)	I_{SY}	$V_S = \pm 1.5\text{V}$	—	19	30	—	19	30	—	19	30	μA
		$V_S = \pm 15\text{V}$	—	25	40	—	25	40	—	25	40	
Capacitive Load Stability		$A_V = +1$ No Oscillations	—	650	—	—	650	—	—	650	—	pF
Input Noise Voltage	e_{np-p}	$f_O = 0.1\text{Hz}$ to 10Hz $V_S = \pm 15\text{V}$	—	3	—	—	3	—	—	3	—	μV_{p-p}

ELECTRICAL CHARACTERISTICS at $V_S = \pm 1.5V$ to $\pm 15V$, $T_A = +25^\circ C$, unless otherwise noted. *Continued*

PARAMETER	SYMBOL	CONDITIONS	OP-290A/E			OP-290F			OP-290G			UNITS
			MIN	TYP	MAX	MIN	TYP	MAX	MIN	TYP	MAX	
Input Resistance Differential-Mode	R_{IN}	$V_S = \pm 15V$	—	30	—	—	30	—	—	30	—	$M\Omega$
Input Resistance Common-Mode	R_{INCM}	$V_S = \pm 15V$	—	20	—	—	20	—	—	20	—	$G\Omega$
Slew Rate	SR	$A_V = +1$ $V_S = \pm 15V$	5	12	—	5	12	—	5	12	—	V/ms
Gain Bandwidth Product	GBWP	$A_V = +1$ $V_S = \pm 15V$	—	20	—	—	20	—	—	20	—	kHz
Channel Separation	CS	$f_O = 10Hz$ $V_O = 20V_{p-p}$ $V_S = \pm 15V$ (Note 2)	120	150	—	120	150	—	120	150	—	dB

NOTES:

- Guaranteed by CMR test.
- Guaranteed but not 100% tested.

ELECTRICAL CHARACTERISTICS at $V_S = \pm 1.5V$ to $\pm 15V$, $-55^\circ C \leq T_A \leq 125^\circ C$, unless otherwise noted.

PARAMETER	SYMBOL	CONDITIONS	OP-290A			UNITS
			MIN	TYP	MAX	
Input Offset Voltage	V_{OS}		—	80	500	μV
Average Input Offset Voltage Drift	TCV_{OS}	$V_S = \pm 15V$	—	0.3	3	$\mu V/^\circ C$
Input Offset Current	I_{OS}	$V_{CM} = 0V$	—	0.1	5	nA
Input Bias Current	I_B	$V_{CM} = 0V$	—	4.2	20	nA
Large Signal Voltage Gain	A_{VO}	$V_S = \pm 15V$, $V_O = \pm 10V$ $R_L = 100k\Omega$	225	400	—	V/mV
		$R_L = 10k\Omega$	125	240	—	
		$R_L = 2k\Omega$	50	110	—	
		$V_+ = 5V$, $V_- = 0V$, $1V < V_O < 4V$ $R_L = 100k\Omega$	100	200	—	
		$R_L = 10k\Omega$	50	110	—	
Input Voltage Range	IVR	$V_+ = 5V$, $V_- = 0V$ $V_S = \pm 15V$ (Note 1)	0/3.5 -15/13.5	—	—	V
Output Voltage Swing	V_O	$V_S = \pm 15V$ $R_L = 10k\Omega$	± 13	± 14.1	—	V
		$R_L = 2k\Omega$	± 10	± 11	—	
		$V_+ = 5V$, $V_- = 0V$ $R_L = 2k\Omega$	3.9	4.1	—	
		$V_+ = 5V$, $V_- = 0V$ $R_L = 10k\Omega$	—	10	100	
Common-Mode Rejection	CMR	$V_+ = 5V$, $V_- = 0V$, $0V < V_{CM} < 3.5V$ $V_S = \pm 15V$, $-15V < V_{CM} < 13.5V$	80 90	105 115	—	dB
Power Supply Rejection Ratio	PSRR		—	3.2	10	$\mu V/V$
Supply Current (All Amplifiers)	I_{SY}	$V_S = \pm 1.5V$	—	30	50	μA
		$V_S = \pm 15V$	—	38	60	

NOTE:

- Guaranteed by CMR test.

OP-290

ELECTRICAL CHARACTERISTICS at $V_S = \pm 1.5V$ to $\pm 15V$, $-40^\circ C \leq T_A \leq 85^\circ C$ for OP-290E/F/G, unless otherwise noted.

PARAMETER	SYMBOL	CONDITIONS	OP-290E			OP-290F			OP-290G			UNITS
			MIN	TYP	MAX	MIN	TYP	MAX	MIN	TYP	MAX	
Input Offset Voltage	V_{OS}		—	70	400	—	115	600	—	200	750	μV
Average Input Offset Voltage Drift	TCV_{OS}	$V_S = \pm 15V$	—	0.3	3	—	0.6	5	—	1.2	—	$\mu V/^\circ C$
Input Offset Current	I_{OS}	$V_{CM} = 0V$	—	0.1	3	—	0.1	5	—	0.1	7	nA
Input Bias Current	I_B	$V_{CM} = 0V$	—	4.2	15	—	4.2	20	—	4.2	25	nA
Large Signal Voltage Gain	A_{VO}	$V_S = \pm 15V, V_O = \pm 10V$										V/mV
		$R_L = 100k\Omega$	500	800	—	350	700	—	300	600	—	
		$R_L = 10k\Omega$	250	400	—	175	350	—	150	250	—	
		$R_L = 2k\Omega$	100	200	—	75	150	—	75	125	—	
		$V_+ = 5V, V_- = 0V,$ $1V < V_O < 4V$										
		$R_L = 100k\Omega$	150	280	—	100	220	—	80	160	—	
		$R_L = 10k\Omega$	75	140	—	50	110	—	40	90	—	
Input Voltage Range	IVR	$V_+ = 5V, V_- = 0V$ $V_S = \pm 15V$ (Note 1)	0/3.5 -15/13.5	—	—	0/3.5 -15/13.5	—	—	0/3.5 -15/13.5	—	—	V
Output Voltage Swing	V_O	$V_S = \pm 15V$										V
		$R_L = 10k\Omega$	± 13	± 14	—	± 13	± 14	—	± 13	± 14	—	
		$R_L = 2k\Omega$	± 10	± 11	—	± 10	± 11	—	± 10	± 11	—	
Output Voltage Swing	V_{OH}	$V_+ = 5V, V_- = 0V$ $R_L = 2k\Omega$	3.9	4.1	—	3.9	4.1	—	3.9	4.1	—	V
		$V_+ = 5V, V_- = 0V$ $R_L = 10k\Omega$	—	10	100	—	10	100	—	10	100	μV
Common-Mode Rejection	CMR	$V_+ = 5V, V_- = 0V,$ $0V < V_{CM} < 3.5V$	85	105	—	80	100	—	80	100	—	dB
		$V_S = \pm 15V,$ $-15V < V_{CM} < 13.5V$	95	115	—	90	110	—	90	110	—	
Power Supply Rejection Ratio	PSRR		—	3.2	7.5	—	5.6	10	—	5.6	15	$\mu V/V$
Supply Current (All Amplifiers)	I_{SY}	$V_S = \pm 1.5V$	—	24	50	—	24	50	—	24	50	μA
		$V_S = \pm 15V$	—	31	60	—	31	60	—	31	60	

NOTE:

1. Guaranteed by CMR test.

DICE CHARACTERISTICS

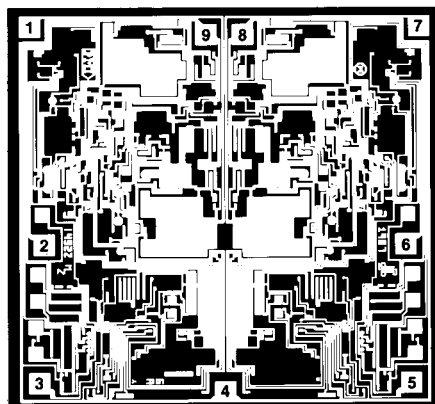

- 1. OUT A
- 2. -IN A
- 3. +IN A
- 4. V-
- 5. +IN B
- 6. -IN B
- 7. OUT B
- 8. V+ B
- 9. V+ A

DIE SIZE 0.109 × 0.104 inch, 11,336 sq. mils
(2.77 × 1.70mm, 4.71 sq. mm)

WAFER TEST LIMITS at $V_S = \pm 1.5V$ to $\pm 15V$, $T_A = 25^\circ C$, unless otherwise noted.

PARAMETER	SYMBOL	CONDITIONS	OP-290GBC LIMIT	UNITS
Input Offset Voltage	V_{OS}		300	μV MAX
Input Offset Current	I_{OS}	$V_{CM} = 0V$	5	nA MAX
Input Bias Current	I_B	$V_{CM} = 0V$	20	nA MAX
Large Signal Voltage Gain	A_{VO}	$V_S = \pm 15V, V_O = \pm 10V$ $R_L = 100k\Omega$	500	V/mV MIN
		$R_L = 10k\Omega$ $V+ = 5V, V- = 0V,$ $1V < V_O < 4V$ $R_L = 100k\Omega$	250	V/mV MIN
Input Voltage Range	IVR	$V+ = 5V, V- = 0V$ $V_S = \pm 15V$ (Note 1)	0/4 -15/13.5	V MIN
Output Voltage Swing	V_O	$V_S = \pm 15V$ $R_L = 10k\Omega$ $R_L = 2k\Omega$	± 13.5 ± 10.5	V MIN
	V_{OH}	$V+ = 5V, V- = 0V$ $R_L = 2k\Omega$	4.0	V MIN
	V_{OL}	$V+ = 5V, V- = 0V$ $R_L = 10k\Omega$	50	μV MAX
Common-Mode Rejection	CMR	$V+ = 5V, V- = 0V, 0V < V_{CM} < 4V$ $V_S = \pm 15V, -15V < V_{CM} < 13.5V$	80 90	dB MIN
Power Supply Rejection Ratio	PSRR		5.6	$\mu V/V$ MAX
Supply Current (All Amplifiers)	I_{SY}	$V_S = \pm 15V$	40	μA MAX

NOTES:

1. Guaranteed by CMR test.

Electrical tests are performed at wafer probe to the limits shown. Due to variations in assembly methods and normal yield loss, yield after packaging is not guaranteed for standard product dice. Consult factory to negotiate specifications based on dice lot qualification through sample lot assembly and testing.

OP-290

TYPICAL PERFORMANCE CHARACTERISTICS

INPUT OFFSET VOLTAGE vs TEMPERATURE

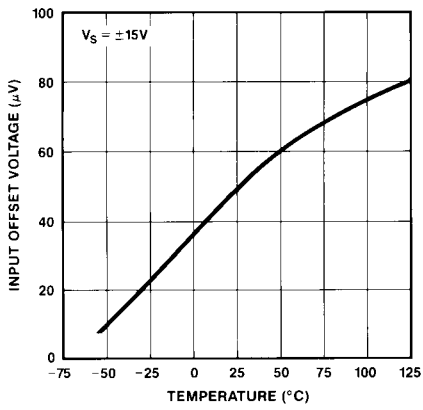

INPUT OFFSET CURRENT vs TEMPERATURE

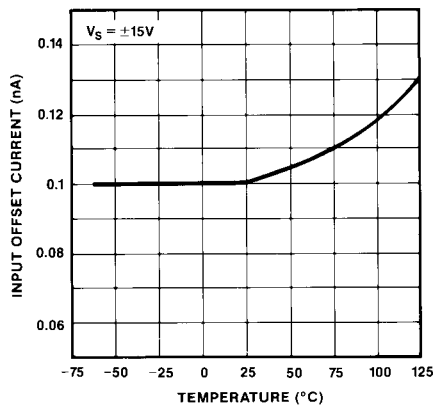

INPUT BIAS CURRENT vs TEMPERATURE

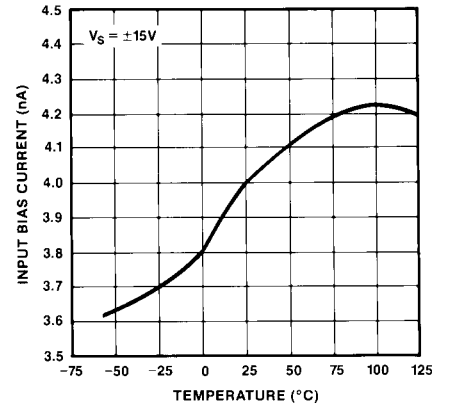

SUPPLY CURRENT vs TEMPERATURE

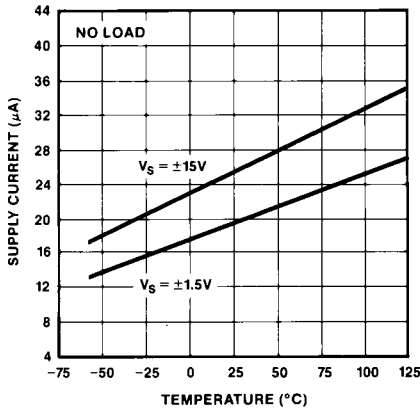

OPEN-LOOP GAIN vs SINGLE-SUPPLY VOLTAGE

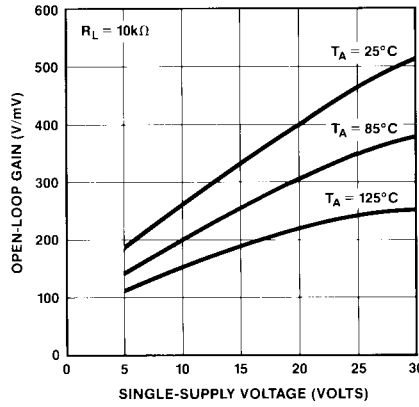

OPEN-LOOP GAIN AND PHASE SHIFT vs FREQUENCY

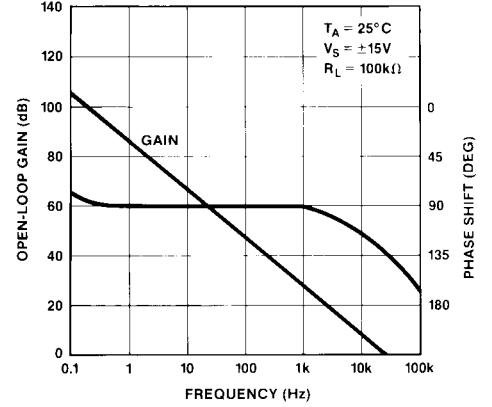

CLOSED-LOOP GAIN vs FREQUENCY

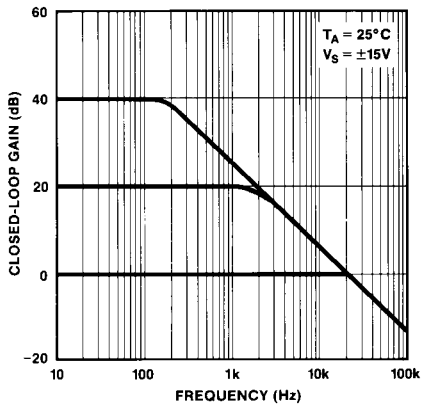

OUTPUT VOLTAGE SWING vs LOAD RESISTANCE

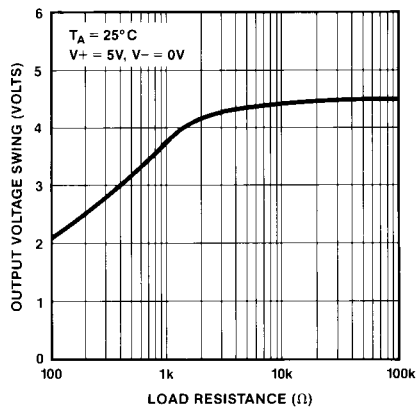

OUTPUT VOLTAGE SWING vs LOAD RESISTANCE

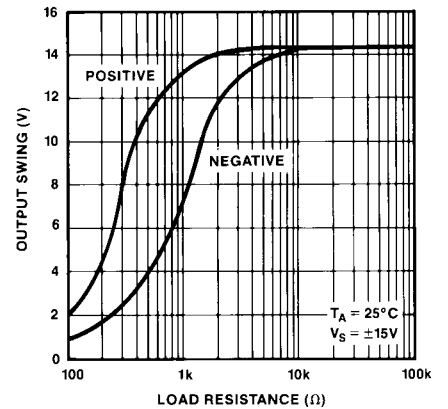

TYPICAL PERFORMANCE CHARACTERISTICS *Continued*

POWER SUPPLY REJECTION vs FREQUENCY

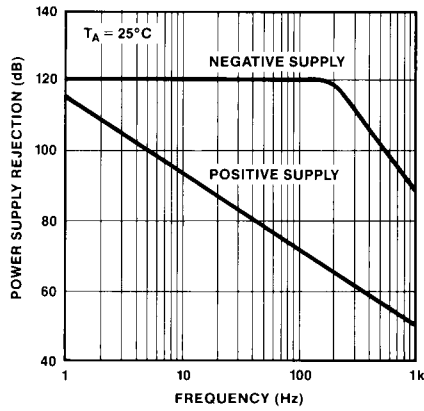

COMMON-MODE REJECTION vs FREQUENCY

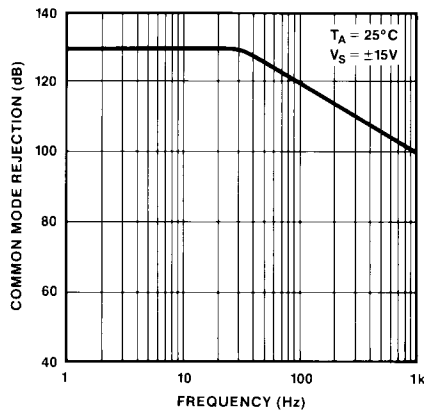

NOISE VOLTAGE DENSITY vs FREQUENCY

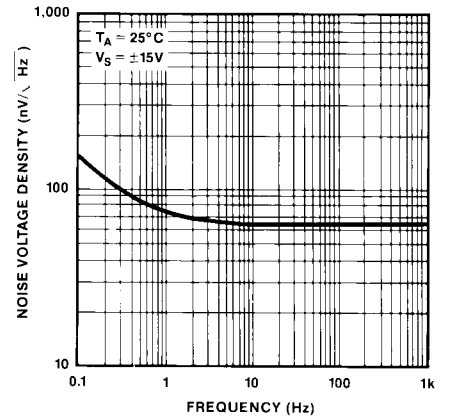

CURRENT NOISE DENSITY vs FREQUENCY

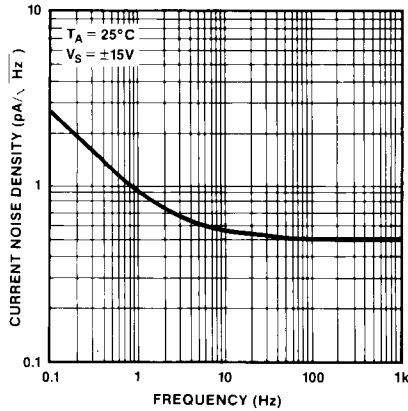

SMALL-SIGNAL TRANSIENT RESPONSE

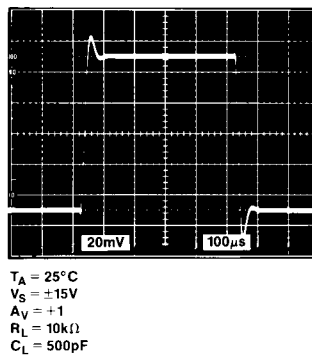

LARGE-SIGNAL TRANSIENT RESPONSE

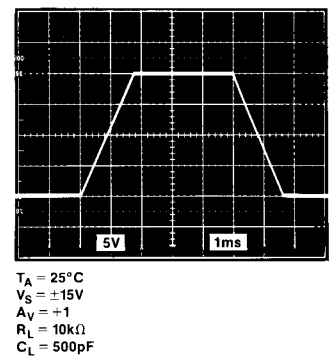

BURN-IN CIRCUIT

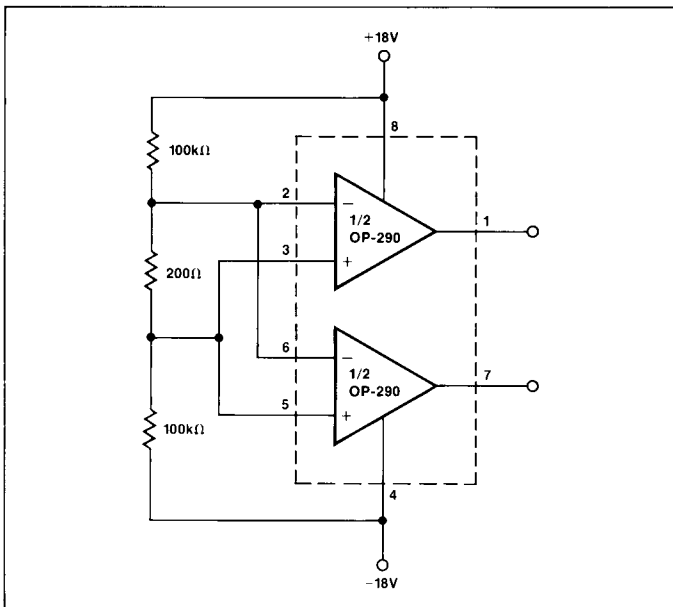

CHANNEL SEPARATION TEST CIRCUIT

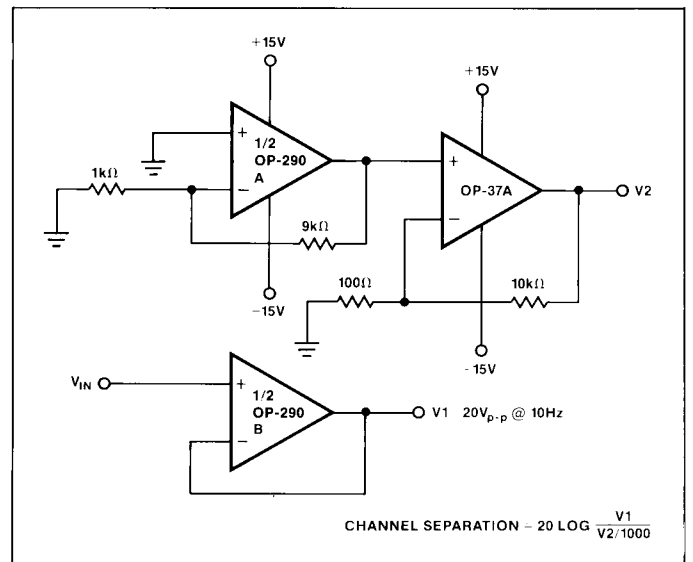

OP-290

APPLICATIONS INFORMATION

BATTERY-POWERED APPLICATIONS

The OP-290 can be operated on a minimum supply voltage of +1.6V, or with dual supplies of $\pm 0.8V$, and draws only $19\mu A$ of supply current. In many battery-powered circuits, the OP-290 can be continuously operated for thousands of hours before requiring battery replacement, reducing equipment downtime and operating cost.

High-performance portable equipment and instruments frequently use lithium cells because of their long shelf-life, light weight, and high energy density relative to older primary cells. Most lithium cells have a nominal output voltage of 3V and are noted for a flat discharge characteristic. The low supply voltage requirement of the OP-290, combined with the flat discharge characteristic of the lithium cell, indicates that the OP-290 can be operated over the entire useful life of the cell. Figure 1 shows the typical discharge characteristic of a 1Ah lithium cell powering an OP-290 with each amplifier, in turn, driving full output swing into a $100k\Omega$ load.

INPUT VOLTAGE PROTECTION

The OP-290 uses a PNP input stage with protection resistors in series with the inverting and noninverting inputs. The high breakdown of the PNP transistors coupled with the protection resistors provides a large amount of input protection, allowing the inputs to be taken 20V beyond either supply without damaging the amplifier.

SINGLE-SUPPLY OUTPUT VOLTAGE RANGE

In single-supply operation the OP-290's input and output ranges include ground. This allows true "zero-in, zero-out" operation. The output stage provides an active pull-down to around 0.8V above ground. Below this level, a load resistance of up to $1M\Omega$ to ground is required to pull the output down to zero.

In the region from ground to 0.8V the OP-290 has voltage gain equal to the data sheet specification. Output current source capability is maintained over the entire voltage range including ground.

APPLICATIONS

TEMPERATURE TO 4-20mA TRANSMITTER

A simple temperature to 4-20mA transmitter is shown in Figure 2. After calibration, the transmitter is accurate to $\pm 0.5^\circ C$ over the $-50^\circ C$ to $+150^\circ C$ temperature range. The transmitter operates from +8V to +40V with supply rejection better than 3ppm/V. One half of the OP-290 is used to buffer the V_{TEMP} pin, while the other half regulates the output current to satisfy the current summation at its noninverting input:

$$I_{OUT} = \frac{V_{TEMP}(R_6 + R_7)}{R_2 R_{10}} - V_{SET} \left(\frac{R_2 + R_6 + R_7}{R_2 R_{10}} \right)$$

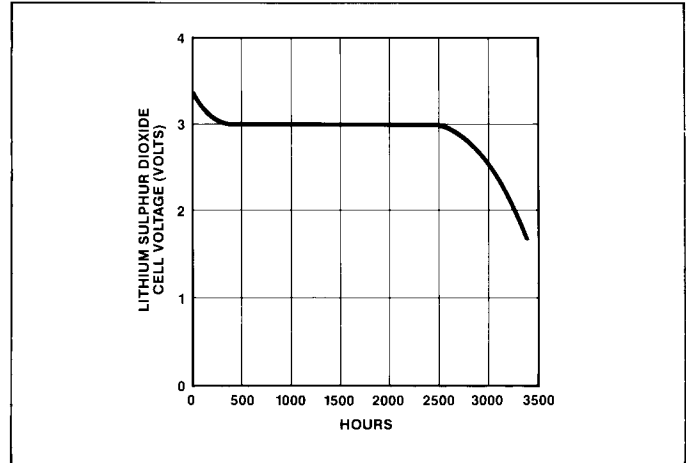

FIGURE 1: Lithium Sulphur Dioxide Cell Discharge Characteristic With OP-290 and $100k\Omega$ Loads

The change in output current with temperature is the derivative of the transfer function:

$$\frac{\Delta I_{OUT}}{\Delta T} = \frac{\Delta V_{TEMP}(R_6 + R_7)}{R_2 R_{10}}$$

From the formulas, it can be seen that if the span trim is adjusted before the zero trim, the two trims are not interactive, which greatly simplifies the calibration procedure.

Calibration of the transmitter is simple. First, the slope of the output current versus temperature is calibrated by adjusting the span trim, R_7 . A couple of iterations may be required to be sure the slope is correct.

Once the span trim has been completed, the zero trim can be made. Remember, that adjusting the offset trim will not affect the gain.

The offset trim can be set at any known temperature by adjusting R_5 until the output current equals:

$$I_{OUT} = \left(\frac{\Delta I_{FS}}{\Delta T_{OPERATING}} \right) (T_{AMBIENT} - T_{MIN}) + 4mA$$

Table 1 shows the values of R_6 required for various temperature ranges.

TABLE 1

TEMP RANGE	R_6
0°C to +70°C	10k
-40°C to +85°C	6.2k
-55°C to +150°C	3k

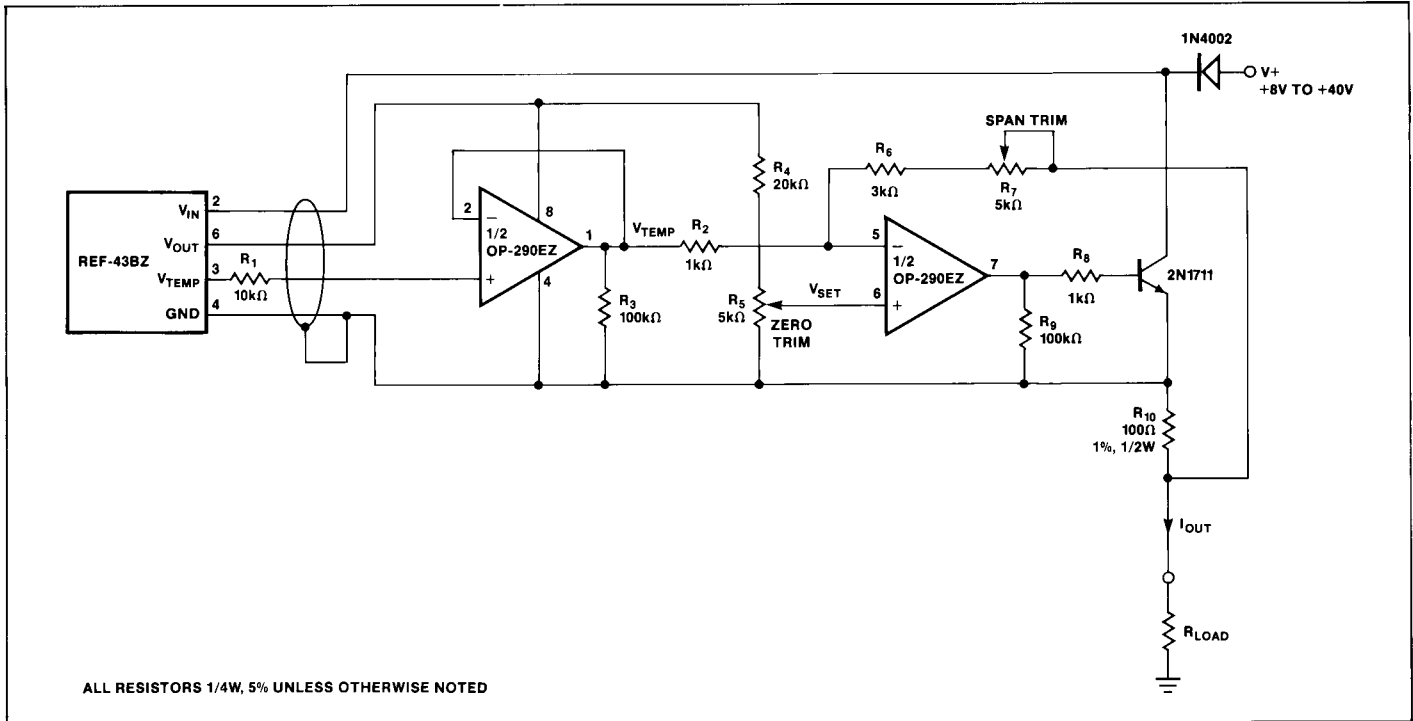

FIGURE 2: Temperature to 4-20mA Transmitter

VARIABLE SLEW RATE FILTER

The circuit shown in Figure 3 can be used to remove pulse noise from an input signal without limiting the response rate to a genuine signal. The non-linear filter has use in applications where the input signal of interest is known to have physical limitations. An example of this is a transducer output where a change of temperature or pressure cannot exceed a certain rate due to physical limitations of the environment. The filter consists of a comparator which drives an integrator. The comparator compares the input voltage to the output voltage and forces the integrator output to equal the input voltage. A₁ acts as a comparator with its output high or low. Diodes D₁ and D₂ clamp the voltage across R₃ forcing a constant current to flow in or out of C₂. R₃, C₂ and A₂ form an integrator with A₂'s output slewing at a maximum rate of:

$$\text{Maximum slew rate} = \frac{V_D}{R_3 C_2} \approx \frac{0.6V}{R_3 C_2}$$

For an input voltage slewing at a rate under this maximum slew rate, the output simply follows the input with A₁ operating in its linear region.

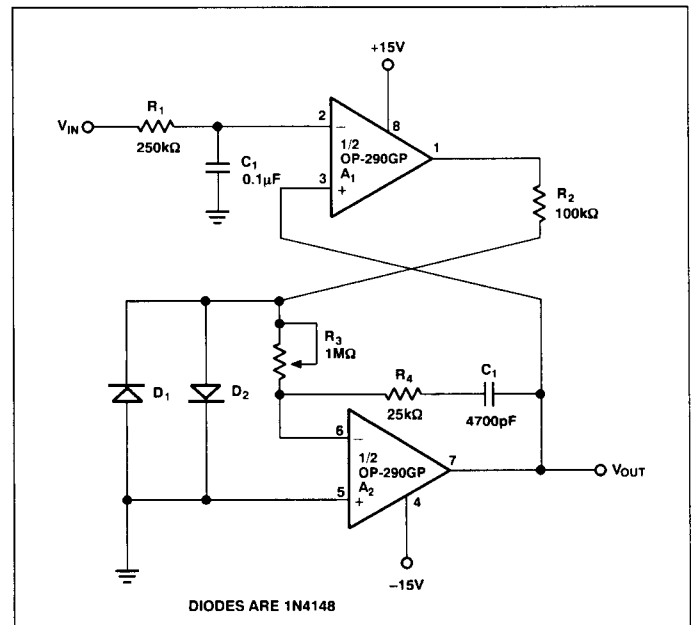

FIGURE 3: Variable Slew Rate Filter

OP-290

LOW OVERHEAD VOLTAGE REFERENCE

Figure 4 shows a voltage reference which requires only 0.1V of overhead voltage. As shown, the reference provides a stable +4.5V output with a +4.6V to +36V supply. Output voltage drift is only 12ppm/°C. Line regulation of the reference is under 5μV/V with load regulation better than 10μV/mA with up to 50mA of output current.

The REF-43 provides a stable 2.5V which is multiplied by the OP-290. The PNP output transistor enables the output voltage to approach the supply voltage.

Resistors R₁ and R₂ determine the output voltage:

$$V_{OUT} = 2.5V \left(1 + \frac{R_2}{R_1} \right)$$

The 200Ω variable resistor is used to trim the output voltage. For the lowest temperature drift, parallel resistors can be used in place of the variable resistor and taken out of the circuit as required to adjust the output voltage.

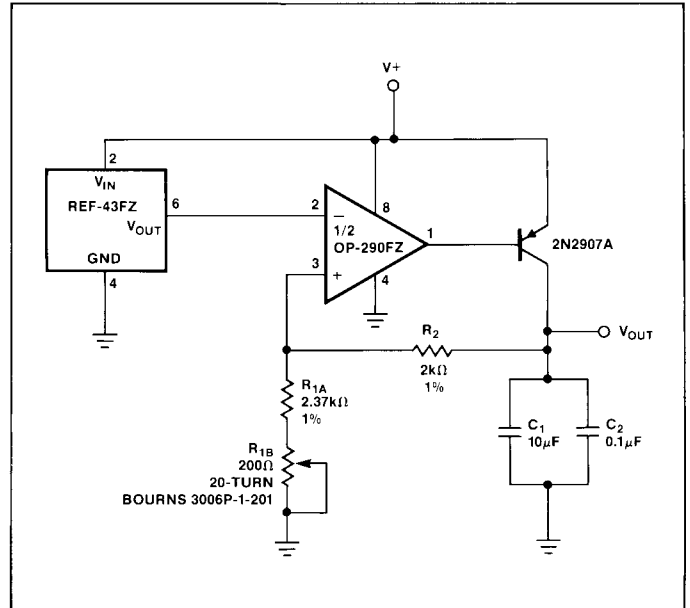

FIGURE 4: Low Overhead Voltage Reference