

ADV601LC

VideoPipe User's Guide

Quick Start, as easy as 1, 2, 3.

- 1. Connect S-video or composite video outputs on right side of VideoPipe to TV monitor.**
- 2. Connect NTSC or PAL video source to S-video or composite inputs on left side of VideoPipe. VideoPipe auto-senses which input is used. *If no source of video available, skip to step 3 for now.***
- 3. Connect wall socket power supply provided, Hit Reset Button and enjoy the video!**

Table of Contents

VideoPipe Contents	4
Suggested Video Equipment	4
Separately Purchased Material for Advanced Users	4
VideoPipe Installation	4
Jumper Settings, Test Points, Other Connections	5
VideoPipe Functionality	6
The PushButtons	6
Function Parameters	6
VideoPipe Hardware	7
ADV601LC VideoPipe Block Diagram	7
VideoPipe Specifications	7
Video Outputs (ranked from worst to best performing)	7
Video Inputs (ranked from worst to best performing)	7
Other Connectors	8
+5V Power J10	8
ADSP-2185 Serial Port (SPORT) JP17	8
EZ-ICE JP16	8
RS-232 P1	8
On-Board CPU	8
Memory	8
Video Decompressor/Compressor	8
Sample Application Performance Reference	9

VideoPipe Contents

- ADV601LC VideoPipe board.
- Wall-plug Power supply
- ADV601LC VideoPipe User's Guide (this document)

Suggested Video Equipment

- color video monitor with CCIR624/RS-170 analog composite or analog Y/C video (PAL or NTSC)
- LaserDisc, VCR, camcorder, or camera with CCIR624/RS-170 analog composite or analog Y/C video output (PAL or NTSC)

Separately Purchased Material for Advanced Users

- ADSP-218x EZ-ICE
- ADSP-21xx family software tools
- ADV601 VideoLAB PCI plug-in board

VideoPipe Installation

Quick Start, as easy as 1, 2, 3.

1. Connect S-video or composite video outputs on right side of VideoPipe to TV monitor.
2. Connect NTSC or PAL video source to S-video or composite inputs on left side of VideoPipe. If no source of video available, skip to set 3 for now.
3. Connect wall socket power supply provided, Hit Reset Button and enjoy the video.

Jumper Settings, Test Points, Other Connections

Jumper/ Connector	Function	Usage	Typical Setting	Alternate Setting
J12	CCIR656 video input connector @ TTL Levels	Professional D1 parallel video sources such as Digital Betacam and D5	Unused	Connected to customers built equipment
J13	CCIR656 video output connector @ TTL Levels	Professional D1 parallel video destinations	Unused	Connected to customers built equipment
JP16	ADSP-2185 EZ-ICE connector	Advanced developers for DSP code Debug via 2185 EZ-ICE	Unused	Connected to ADSP- 2185 EZ-ICE via connector supplied with ADSP-2185 EZ- ICE
JP17	ADSP-2185 Serial Port (SPORT) connector	Advanced developers for routing compressed video to/from the DSP to other system components	Unused	Connected to customers built equipment
JP5	Video Clock Source	Used to select between SAA7111 line-locked clock source (1-2 short) for ADV601LC or CCIR656 digital video clock source for ADV601LC.	1-2 short when input video is composite or Y/C.	open when ECL CCIR656 interface board is used <u>and</u> valid CCIR656 digital input is present.
P1	RS-232 connector	Real-time display of diagnostic and compressed bit rate data	Unused	Connected to PC COM port via provided RS-232 cable adaptor

VideoPipe Functionality

The PushButtons

Button	Button Description
Select Button (S3)	<p>Selects which parameters are controlled by the up button and the down button.</p> <p><i>Press Select 0 time(s), Up/Down controls Compression Ratio</i></p> <p><i>Press Select 1 time(s), Up/Down controls Field/sec</i></p> <p><i>Press Select 2 time(s), Up/Down controls Image Resolution</i></p> <p><i>Press Select 3 time(s), Up/Down controls Compression Ratio etc....</i></p>
Up Button (S1)	Moves Up list of parameters (see lists to right)
Down Button (S2)	Moves Down list of parameters (see lists to right)
Freeze Button (S4)	<p>Freezes current Image on the TV monitor for close visual analysis</p> <p><i>Fields are automatically doubled and some Color Sub-Carrier phase error may be seen</i></p>
Reset Button (S5)	Hardware and Software Reset

Function Parameters

Select Button	Up Button Down Button	Reset Value
Select Button pushed 0 times to control Bit Rate in Mbps	<ul style="list-style-type: none"> • 5 • 8 • 11 • 12 • 17 • 18 • 19 • 20 • 21 • 23 • 25 • 27 • 41 • 65 • 81 <p><i>All Values expressed as compression Ratio</i></p>	20
Select Button pushed 1 time to control Field/sec	<ul style="list-style-type: none"> • 60/50 • 30/25 • 15/12.5 • 12 • 10 • 5 • 1 <p><i>All Values Fields/sec</i></p>	60/50
Select Button pushed 2 times to control Image Resolution	<ul style="list-style-type: none"> • CCIR601 (0) • CIF (1) • QCIF (2) • QQCIF (3) • QQQCIF (4) • QQQQCIF (5) 	1
Select Button pushed 3, 6, ... times loops to the top of column		

VideoPipe Hardware

ADV601LC VideoPipe Block Diagram

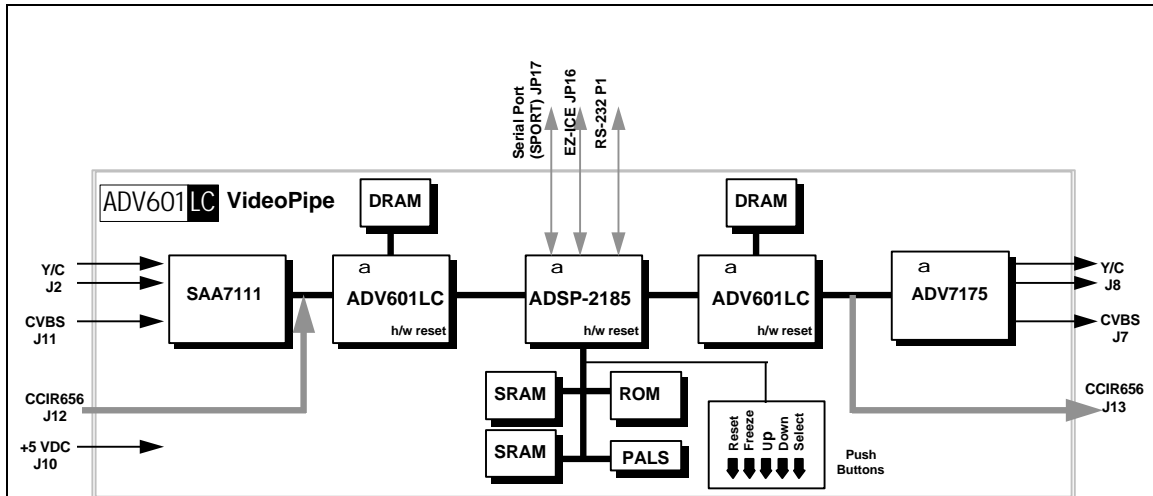

VideoPipe Specifications

Video Outputs (ranked from worst to best performing)

1. J7 PAL (CCIR624) or NTSC (RS-170) **composite analog** output via RCA connector on right side of board. Analog Devices ADV7176 encoder used.
2. J8 PAL or NTSC **S-video analog** output via 4-pin DIN connector on right side of board. Analog Devices ADV7176 encoder used.
3. J13 Optional **8-bit parallel D1** (CCIR656) @ TTL signaling (see schematics for pin definition). 14-pin 100-mil dual row header (provided) must be installed by user.

Video Inputs (ranked from worst to best performing)

1. J11 Auto-sensing PAL (CCIR624) or NTSC (RS-170) **composite analog** inputs via RCA connector (75W terminated) on left side of board. Philips SAA7111 decoder used. Overall compression performance of the VideoPipe is limited to the performance of the SAA7111. Advanced users should use the 8-bit parallel D1 (CCIR656) interface.
2. J2 Auto-sensing PAL or NTSC **S-video analog** inputs via 4-pin DIN connector (75W terminated) on left side of board. Philips SAA7111 decoder used. Superior to composite input.
3. J12 Optional **8-bit parallel D1** (CCIR656) @ TTL signaling (see schematics for pin definition). 14-pin 100-mil dual row header (provided) must be installed by user. **Recommended for best Video performance.**

Other Connectors

+5V Power J10

5 Volts DC @ 3 Watts provided by wall socket power supply.

ADSP-2185 Serial Port (SPORT) JP17

7-pin keyed 100-mil single row header (provided) must be installed by user. For advanced users when interfacing compressed bit streams to external systems. Required that special code be developed by the user for the ADSP-2185.

EZ-ICE JP16

14-pin keyed 100-mil dual row header (provided) must be installed by user. For advanced users when developing user code for ADSP-2185.

RS-232 P1

10-pin keyed 100-mil dual row header (provided) must be installed by user. For advanced users when monitoring diagnostics from ADSP-2185 or when developing user code for ADSP-2185.

On-Board CPU

ADSP-2185 16 bit DSP with 80k bytes of on-chip memory and 33 MIP performance.

Memory

- 2 4-Mbit SRAM for ADSP-2185 compressed video field storage.
- 1 4-Mbit ROM for ADSP-2185 for control code (excessively large for future expansion)
- 1 4-Mbit -60 EDO DRAM for each ADV601LC (total 2)

Video Decompressor/Compressor

ADV601LC in 120 pin 14x14 mm 0.5 mm pitch TQFP.

Sample Application Performance Reference

Video Comp. Ratio	Video Bit Rate (Mbps)	Example Application
5.0	33.6E+6	Professional Quality Video Capture and non-linear Editing
8.5	19.7E+6	ATSC VSB8 Terrestrial Digital Broadcast bit rate
11.8	14.1E+6	DVHS Standard Mode Bit Rate
17.2	9.7E+6	12 Mbps USB with 19 64-byte isochronous pipes
18.2	9.2E+6	12 Mbps USB with 18 64-byte isochronous pipes
19.3	8.7E+6	IDE/ISA Video Capture
20.5	8.2E+6	12 Mbps USB with 16 64-byte isochronous pipes
21.8	7.7E+6	12 Mbps USB with 15 64-byte isochronous pipes
23.4	7.2E+6	12 Mbps USB with 14 64-byte isochronous pipes
25.2	6.7E+6	12 Mbps USB with 13 64-byte isochronous pipes
27.3	6.1E+6	12 Mbps USB with 12 64-byte isochronous pipes
41.0	4.1E+6	
65.5	2.6E+6	
81.9	2.0E+6	Radio Modem