



**Fundusze Europejskie**  
Wiedza Edukacja Rozwój



**Rzeczpospolita  
Polska**

**Unia Europejska**  
Europejski Fundusz Społeczny



**Politechnika Śląska jako Centrum Nowoczesnego Kształcenia  
opartego o badania i innowacje**

**POWR.03.05.00-IP.08-00-PZ1/17**

**Projekt współfinansowany przez Unię Europejską ze środków Europejskiego Funduszu Społecznego**

# **Microprocessor and Embedded Systems**

**Faculty of Automatic Control, Electronics and Computer Science,  
Informatics, Bachelor Degree**

# Lecture 3

---

## **8051 single-chip microcomputer Part 1 General architecture**

**Bartłomiej Zieliński, PhD, DSc**

# 8051 (1)

---

Program:

(today)

- Genesis of single-chip  $\mu\text{c}$
- 8051 structure
- Memory organisation
- Pins and machine cycles
- Ports structure

(next week)

- Built-in peripherals

# 8051 (1)

---

- Single-chip  $\mu$ c
  - Optimised for control
    - More logical commands
    - Less arithmetical command
    - More I/O capabilities
  - First circuits
    - Texas Instruments – TMS1802NC (1971)
    - Texas Instruments – TMS1000 (1974)
      - 1Kx8 ROM, 64x4 RAM, 23 I/O lines (different versions exist)
    - Intel – 8048 (1976)
      - 1÷4Kx8 ROM/EPROM, 64÷256x8 RAM, 20-27 I/O lines (different versions exist)

# 8051 (1)

---

- Basic properties
  - 111 commands (49 1B, 45 2B, 17 3B)
    - Arithmetical (incl. mul/div), logical, bit, jump, i/o
    - Most execute in 1-2 machine cycles (mul/div – 4)
  - Clock up to 12 MHz (machine cycle 1  $\mu$ s)
  - Separate program and data memories
  - 2-level, 5-source interrupt system
  - Built-in i/o interfaces
    - Timers/counters
    - I/O ports
    - Serial port(s)

# 8051 (1)

---

- Extended versions
  - Philips
    - I<sup>2</sup>C
  - Siemens
    - CAN
  - Dallas/Maxim
    - Improved structure (works 3 times faster)
    - Double DPTR
  - SMC
    - ArcNET
  - TI
    - 8051 with radio interface

# 8051 (1)

---

- General simplified structure

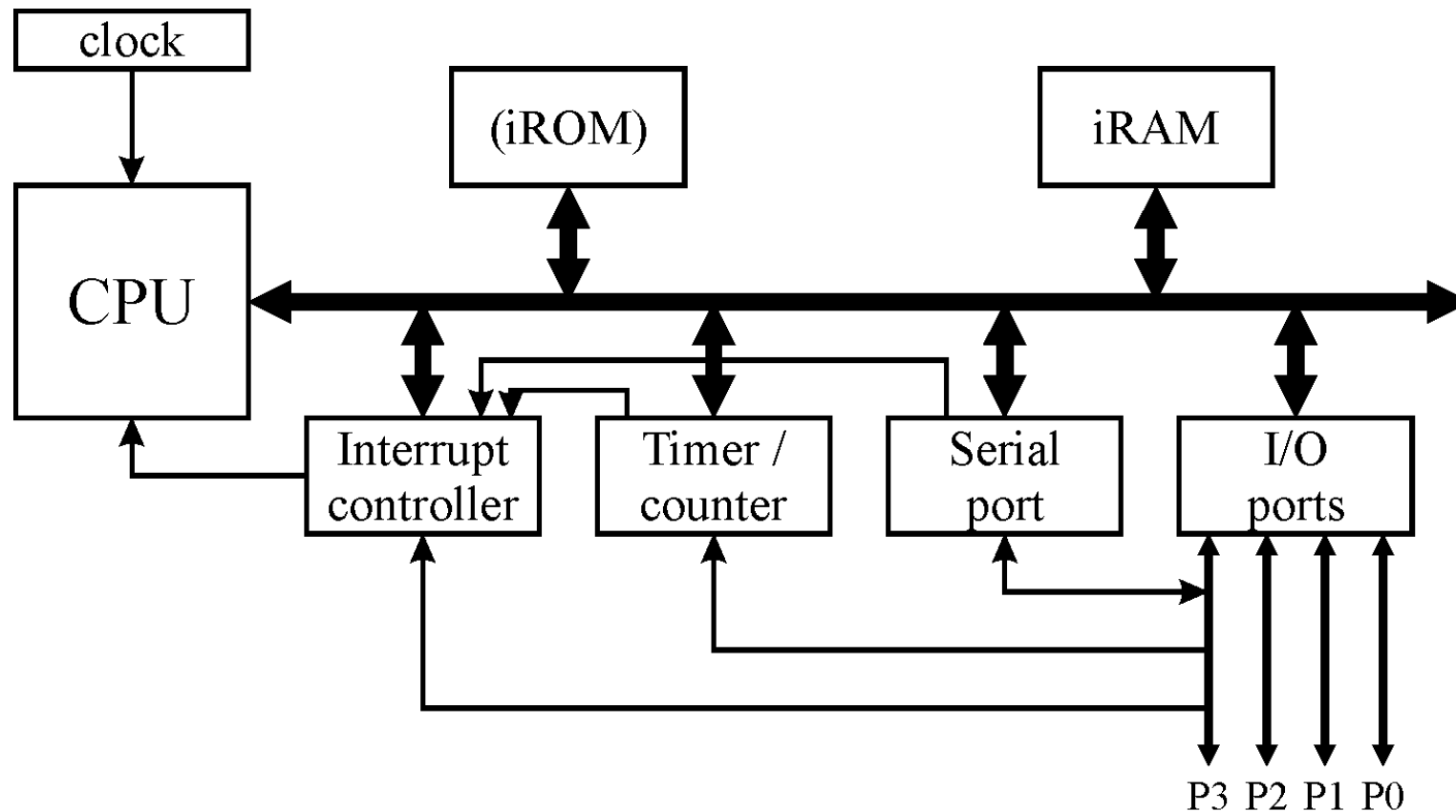

# 8051 (1)

- Memory organisation
  - Program memory
    - Internal, external, or both
    - Single addressing space
  - Data memory
    - Internal and/or external
    - Separate addressing spaces
    - Different commands and addressing modes

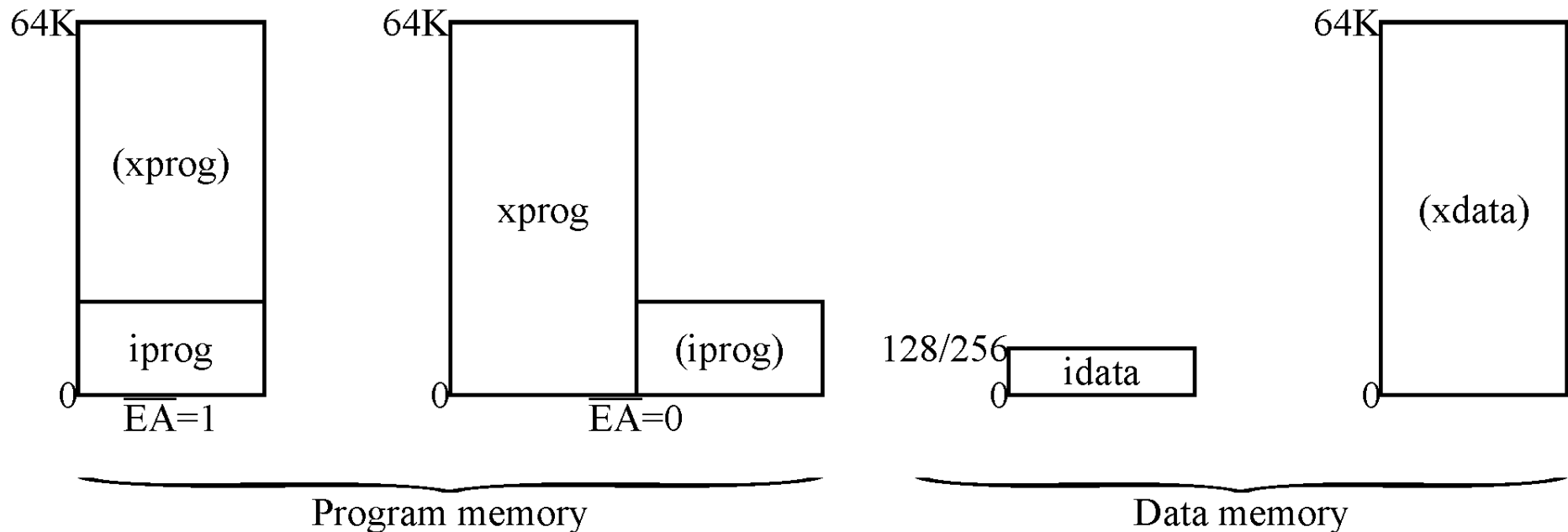



# 8051 (1)

- Internal data memory organisation

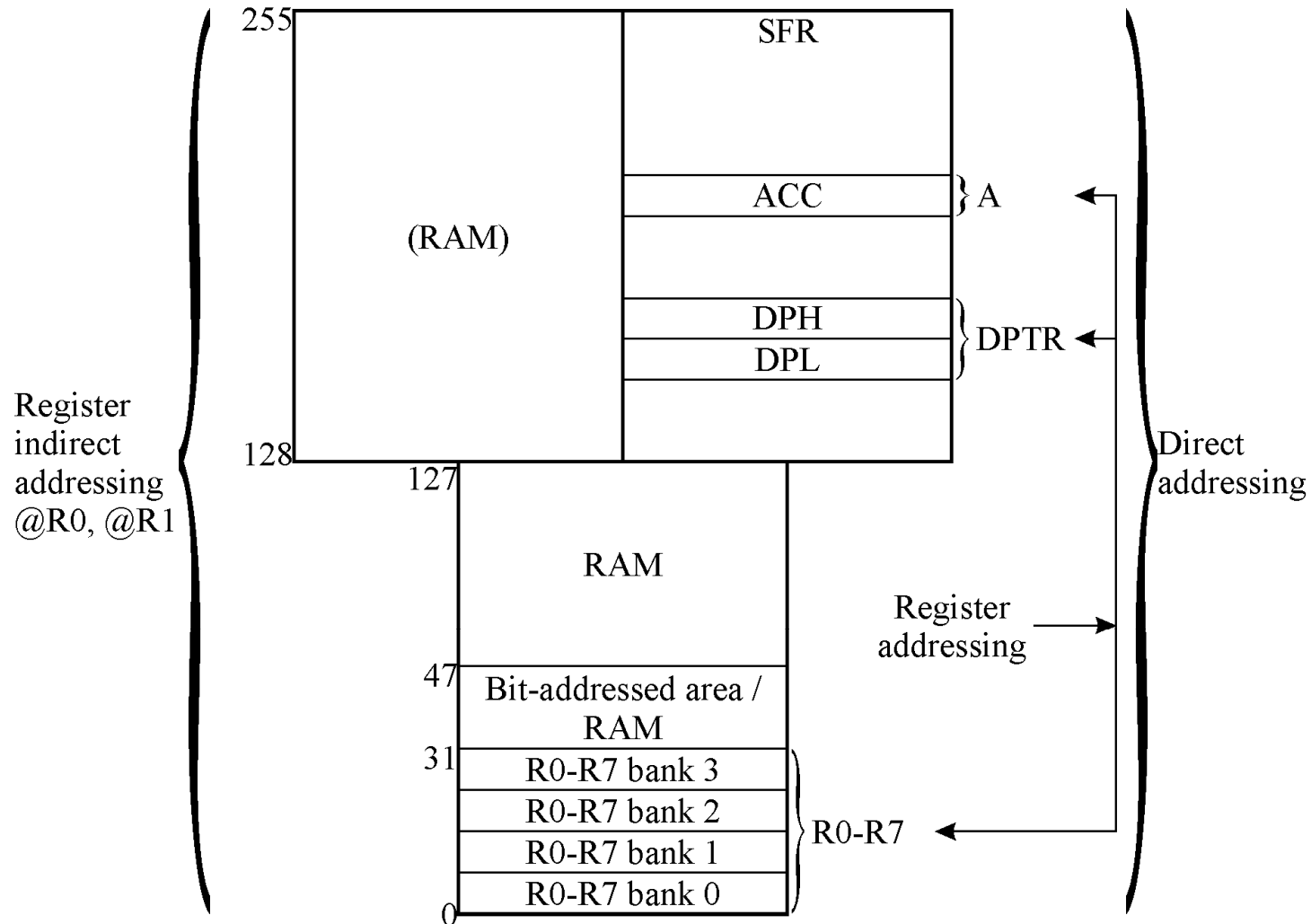

# 8051 (1)

---

- Pinout, signals

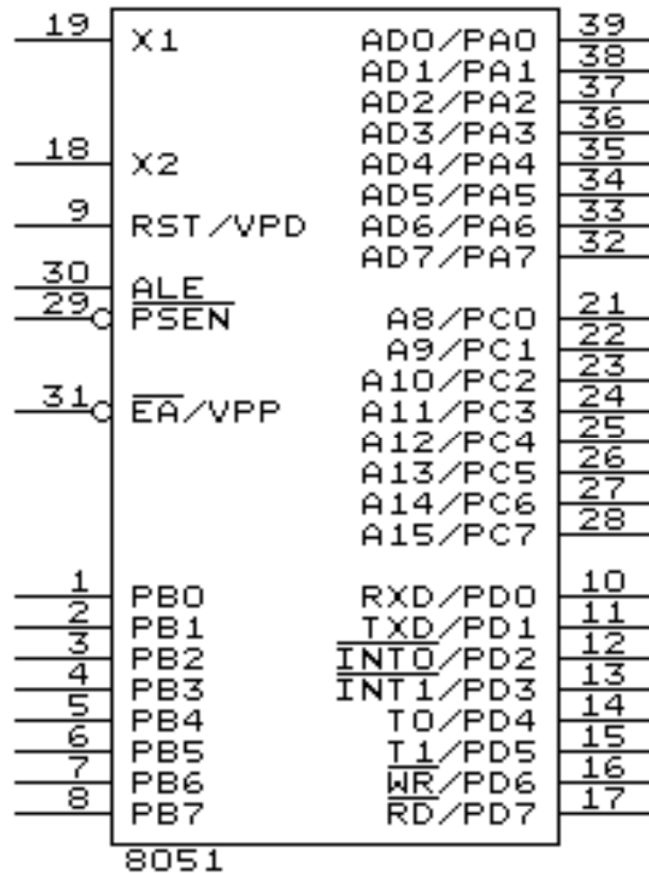

# 8051 (1)

---

- Machine cycle
  - 6 states (S1-S6) of 2 phases (P1-P2) each
  - S1, S4 – command code fetch
  - S2 – command decode, PC++
  - S4 – argument read, idle next command fetch
  
  - Almost all commands – 1-2 machine cycles
  - Mul/div command – 4 machine cycles

# 8051 (1)

- Command code fetch machine cycle

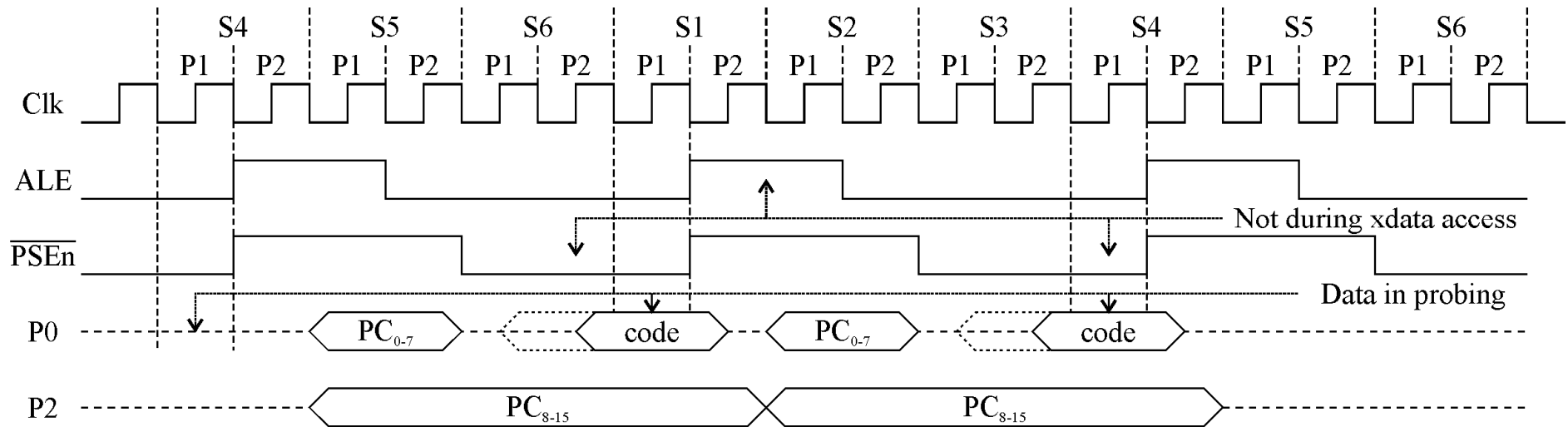

# 8051 (1)

- xdata read/write machine cycles

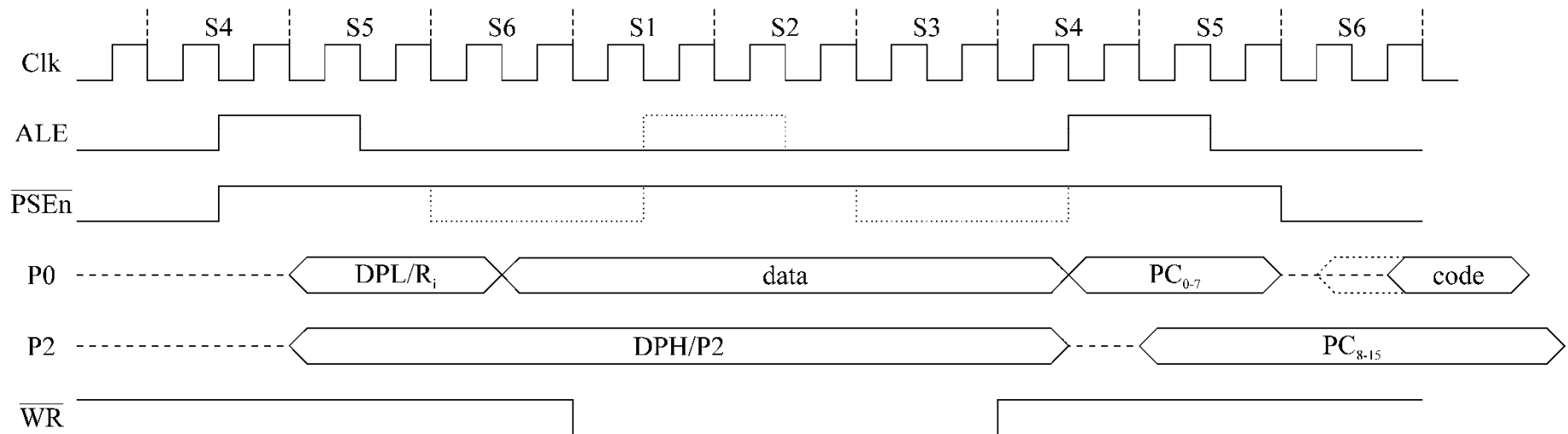
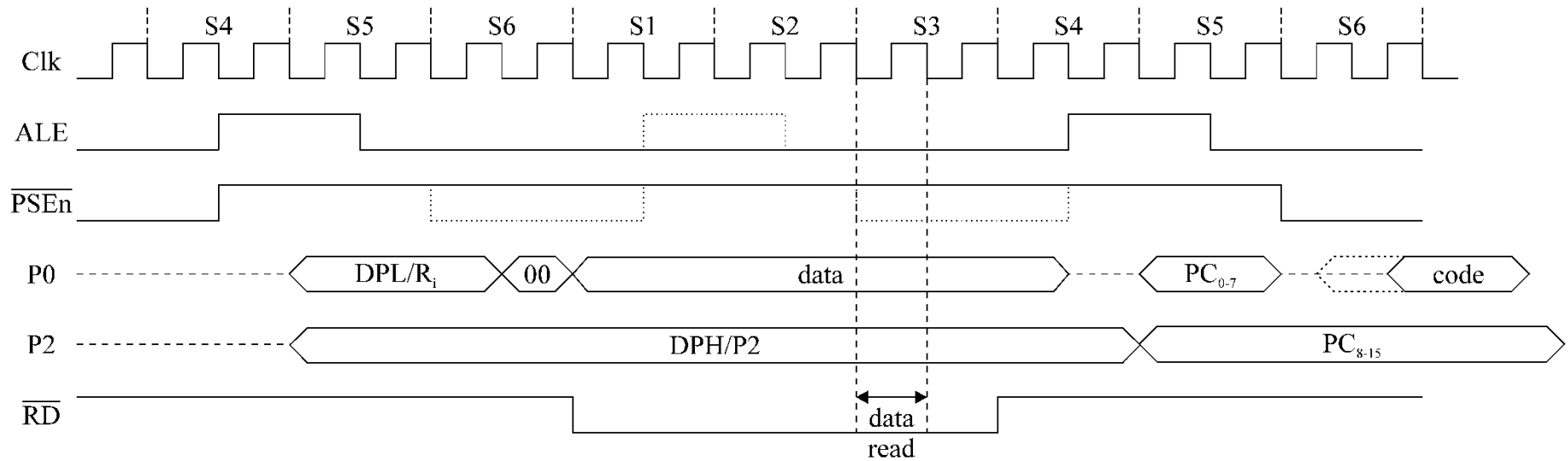

# 8051 (1)

- Command types and machine cycles

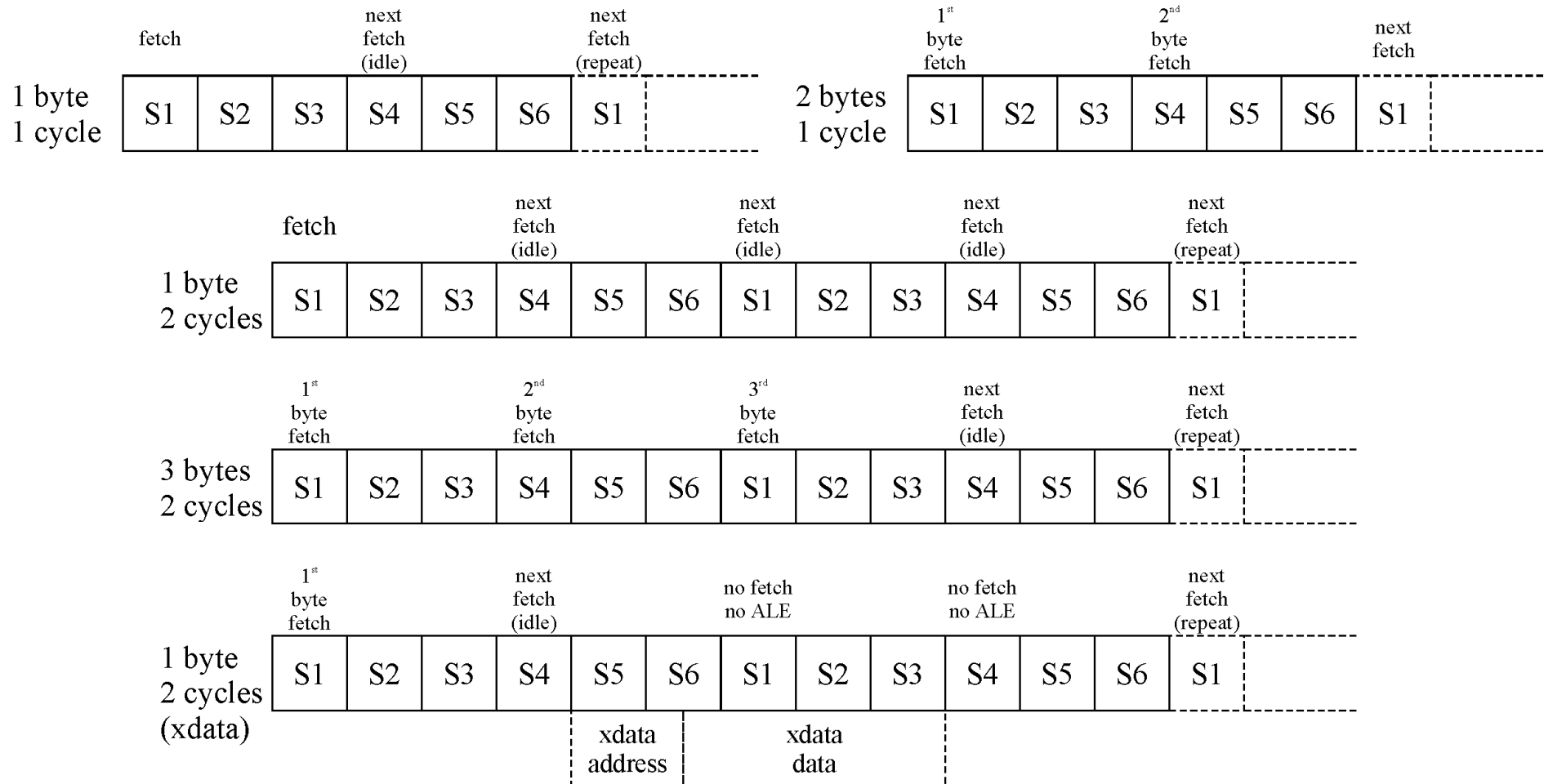

# 8051 (1)

- Ports structure

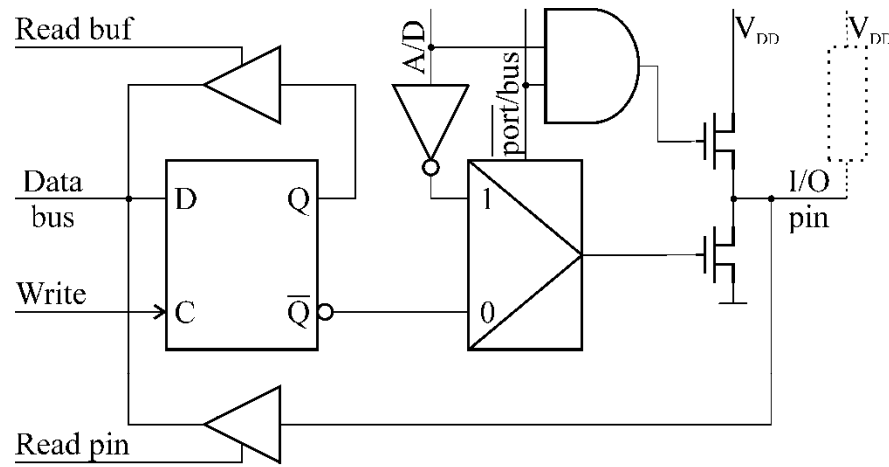

Port 0

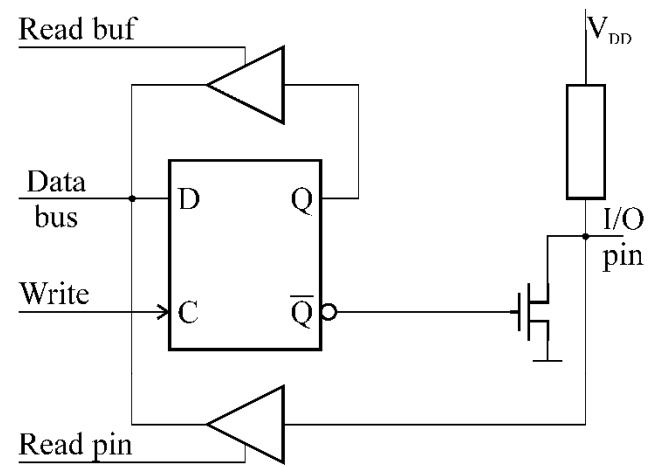

Port 1

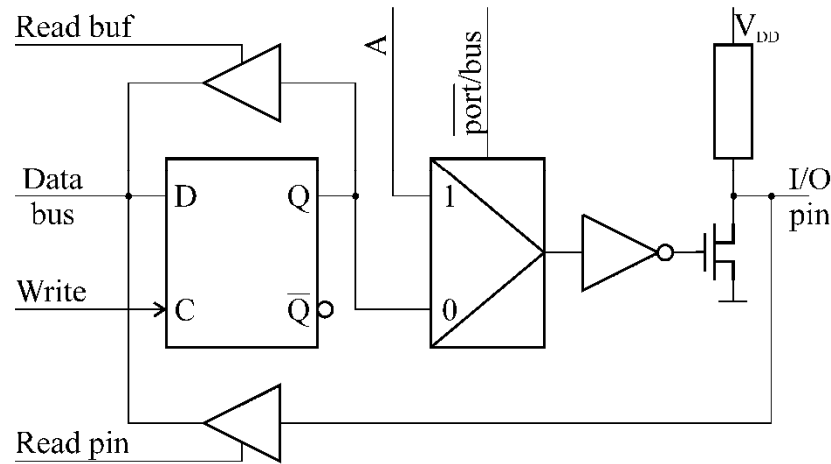

Port 2

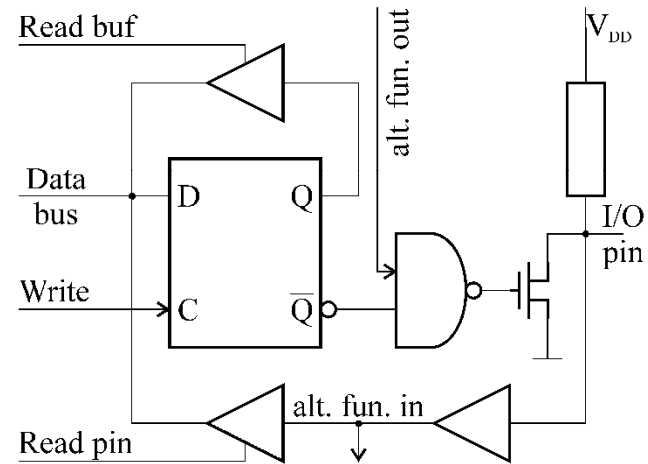

Port 3